

- .3 Control disposal or runoff of water containing suspended materials or other harmful substances in accordance with governing regulations and requirements.
- .4 Provide control devices such as filter fabrics, sediment traps and settling ponds to control drainage and prevent erosion of adjacent lands. Maintain in good order for duration of work.

1.7 SITE AND PLANT PROTECTION

- .1 Protect trees and plants on site and adjacent properties where indicated.
- .2 Wrap in burlap, trees and shrubs adjacent to construction work, storage areas and trucking lanes, and encase with protective wood framework from grade level to height of 2 m.
- .3 Protect roots of designated trees to dripline during excavation and site grading to prevent disturbance or damage. Avoid unnecessary traffic, dumping and storage of materials over root zones.
- .4 Minimize stripping of topsoil and vegetation.
- .5 Restrict tree removal to areas indicated or designated by Owner's Representative.

1.8 WORK ADJACENT TO WATERWAYS

- .1 Do not operate construction equipment in waterways.
- .2 Do not use waterway beds for borrow material.
- .3 Do not dump excavated fill, waste material or debris in waterways.
- .4 At borrow sites, design and construct temporary crossings to minimize erosion to waterways in strict conformance with provincial and federal environmental regulations.
- .5 Do not skid logs or construction materials across waterways.
- .6 Avoid indicated spawning beds when constructing temporary crossings of waterways.
- .7 Do not blast under water or 100 m of spawning beds.
- .8 Do not refuel any type of equipment within 100 meters of a water body. Maintain equipment in good working condition with no fluid leaks, loose hoses or fittings.

1.9 POLLUTION CONTROL

- .1 Maintain temporary erosion and pollution control features installed under this contract.
- .2 Control emissions from equipment and plant to local authorities emission requirements.
- .3 Prevent sandblasting and other extraneous materials from contaminating air beyond application area, by providing temporary enclosures.

- .4 Cover or wet down dry materials and rubbish to prevent blowing dust and debris. Provide dust control for temporary roads and around entire construction site.
- .5 Have appropriate emergency spill response equipment and rapid clean-up kit on site located adjacent to hazardous materials storage area. Provide personal protective equipment required for clean-up.
- .6 Report, spills of petroleum and other hazardous materials as well as accidents having potential of polluting the environment to Federal and Provincial Department of the Environment.
- .7 Notify Owner's Representative and submit a written spill report to Owner's Representative within 24 hours of occurrence.

1.10 WILDLIFE PROTECTION

- .1 Should nests of migratory birds in wetlands be encountered during work, immediately notify Owner's Representative for directives to be followed.
 - .1 Do not disturb nest site and neighbouring vegetation until nesting is completed.
 - .2 Minimize work immediately adjacent to such areas until nesting is completed.
 - .3 Protect these areas by following recommendations of Canadian Wildlife Service.

END OF SECTION

PART 1 - GENERAL

1.1 RELATED DOCUMENTS

- A. Drawings and general provisions of the Contract, including General and Supplementary Conditions and Division 1 Specification Sections, apply to this Section.

1.2 SUMMARY

- A. Types of items described in this Section:
 - 1. References and Codes.

1.3 REFERENCES AND CODES

- A. Perform Work in accordance with National Building Code of Canada (NBCC) including all amendments up to tender closing date and other codes of provincial or local application provided that in case of conflict or discrepancy, more stringent requirements apply.
- B. Meet or exceed requirements of:
 - 1. Contract documents.
 - 2. Specified standards, codes, and referenced documents.

1.4 NATIONAL PARKS ACT

- A. For projects located within boundaries of a National Park, perform Work in accordance with National Parks Act.

PART 2 - PRODUCTS (Not Used)

PART 3 - EXECUTION (Not Used)

END OF SECTION

PART 1 - GENERAL

1.1 SECTION INCLUDES

- .1 Inspection and testing, administrative and enforcement requirements.
- .2 Tests and mix designs.

1.2 RELATED SECTIONS

- .1 Section 01 78 00 – Closeout Submittals

1.3 INSPECTION

- .1 Allow Engineer/Architect access to Work. If part of Work is in preparation at locations other than Place of Work, allow access to such Work whenever it is in progress.
- .2 Give timely notice requesting inspection if Work is designated for special tests, inspections or approvals by Engineer/Architect instructions.
- .3 If Contractor covers or permits to be covered Work that has been designated for special tests, inspections or approvals before such is made, uncover such Work, have inspections or tests satisfactorily completed and make good such Work.
- .4 Engineer/Architect may order any part of Work to be examined if Work is suspected to be not in accordance with Contract Documents. If, upon examination such work is found not in accordance with Contract Documents, correct such Work and pay cost of examination and correction. If such Work is found in accordance with Contract Documents, Engineer/Architect shall pay cost of examination and replacement.

1.4 INDEPENDENT INSPECTION AGENCIES

- .1 Independent Inspection/Testing Agencies may be engaged by Engineer/Architect for purpose of inspecting and/or testing portions of Work.
- .2 Employment of inspection/testing agencies does not relax responsibility to perform Work in accordance with Contract Documents.
- .3 If defects are revealed during inspection and/or testing, appointed agency will request additional inspection and/or testing to ascertain full degree of defect. Correct defect and irregularities as advised by Engineer/Architect at no cost to Engineer/Architect. Pay costs for retesting and re-inspection.

1.5 ACCESS TO WORK

- .1 Allow inspection/testing agencies access to Work, off site manufacturing and fabrication plants.
- .2 Co-operate to provide reasonable facilities for such access.

1.6 PROCEDURES

- .1 Notify appropriate agency and Engineer/Architect in advance of requirement for tests, in order that attendance arrangements can be made.

- .2 Submit samples and/or materials required for testing, as specifically requested in specifications. Submit with reasonable promptness and in an orderly sequence so as not to cause delay in Work.
- .3 Provide labour and facilities to obtain and handle samples and materials on site. Provide sufficient space to store and cure test samples.

1.7 REJECTED WORK

- .1 Remove defective Work, whether result of poor workmanship, use of defective products or damage and whether incorporated in Work or not, which has been rejected by Engineer/Architect as failing to conform to Contract Documents. Replace or re-execute in accordance with Contract Documents.
- .2 Make good other Contractor's work damaged by such removals or replacements promptly.
- .3 If in opinion of Engineer/Architect it is not expedient to correct defective Work or Work not performed in accordance with Contract Documents, Owner may deduct from Contract Price difference in value between Work performed and that called for by Contract Documents, amount of which shall be determined by Engineer/Architect.

PART 2 - PRODUCTS (NOT APPLICABLE)

PART 3 - EXECUTION (NOT APPLICABLE)

END OF SECTION

PART 1 - GENERAL

1.1 RELATED SECTIONS

- .1 Section 01 52 00 – Construction Facilities
- .2 Section 01 56 00 – Temporary Barriers and Enclosures

1.2 INSTALLATION AND REMOVAL

- .1 Provide temporary controls in order to execute Work expeditiously.
- .2 Remove from site all such work after use.

1.3 DEWATERING

- .1 Provide temporary drainage and pumping facilities to keep excavations and site free from standing water.

1.4 WATER SUPPLY

- .1 Arrange for connection with appropriate utility company and pay all costs for installation, maintenance and removal.

1.5 TEMPOARY HEATING AND VENTILATION

- .1 Pay for costs of temporary heat and ventilation used during construction, including costs of installation, fuel operation, maintenance and removal of equipment. Use of direct, fired heaters discharging waste products into work areas will not be permitted unless prior approval is given by Engineer/Architect.
- .2 Construction heaters used inside building must be vented to outside or be non-flameless type. Solid fuel salamanders are not permitted.
- .3 Provide temporary heat and ventilation in enclosed areas as required to:
 - .1 Facilitate progress of Work.
 - .2 Protect Work and products against dampness and cold.
 - .3 Prevent moisture condensation on surfaces.
 - .4 Provide ambient temperatures and humidity levels for storage, installation and curing of materials.
 - .5 Provide adequate ventilation to meet health regulations for safe working environment.
- .4 Maintain temperatures of minimum 10°C and relative humidity less than 60% in areas where construction is in progress.
 - .1 Maintain minimum temperature of 10°C or higher where specified as soon as finished work is commenced. Maintain until acceptance of structure by Engineer/Architect.
 - .2 Maintain ambient temperature and humidity levels as required for comfort of office personnel.
- .5 Ventilating:
 - .1 Prevent accumulations of dust, fumes, mists, vapours or gases in areas occupied during construction.
 - .2 Provide local exhaust ventilation to prevent harmful accumulation of hazardous substances into atmosphere of occupied areas.

- .3 Dispose of exhaust materials in manner that will not result in harmful exposure to persons.
 - .4 Ventilate storage spaces containing hazardous or volatile materials.
 - .5 Ventilate temporary sanitary facilities.
 - .6 Continue operation of ventilation and exhaust system for time after cessation of work process to assure removal of harmful contaminants.
- .6 Maintain strict supervision of operation of temporary heating and ventilating equipment to:
- .1 Conform with applicable codes and standards.
 - .2 Enforce safe practices.
 - .3 Prevent abuse of services.
 - .4 Prevent damage to finishes.
 - .5 Vent direct-fired combustion units to outside.
- .7 Be responsible for damage to Work due to failure in providing adequate heat humidity and protection during construction.
- .8 Use of new or existing systems for temporary heating, ventilating or air conditioning will not be permitted.
- 1.6 TEMPORARY POWER AND LIGHT
- .1 Provide and pay for temporary power during constructing for temporary lighting, heating, site construction trailers and operating of power tools in accordance with governing regulations and the Canadian Electrical Code, latest edition.
 - .2 Arrange for connection with Utility company. Pay all costs for installation maintenance and removal of cables, distribution and branch panel boards, poles, lighting, heating and general power receptacles as required.
 - .3 Temporary power for electric cranes and other equipment requiring in excess of above is responsibility of Contractor.
 - .4 Provide and maintain temporary lighting throughout project. Ensure level of illumination on all floors and stairs is not less than 162 lx. Temporary lighting to consist of wiring, pigtail sockets and 75 watt shatterproof incandescent lamps to provide a minimum light level of 162 lux.
 - .5 Electrical power and lighting systems installed under this contract may be used for construction requirements only with prior approval of Engineer/Architect provided that guarantees are not affected. Make good damage to electrical system caused by use under this contract. Replace lamps which have been used for more than 3 months.
 - .6 General contractor responsible for payment of all electrical energy changes associated with temporary power up to date of substantial completion.
- 1.7 FIRE PROTECTION
- .1 Provide and maintain temporary fire protection equipment during performance of Work required by insurance companies having jurisdiction and governing codes, regulations and bylaws.
 - .2 Burning rubbish and construction waste materials is not permitted on site.
- 1.8 SANITARY FACILITIES

- .1 Provide sanitary facilities for work force in accordance with governing regulations and ordinances.
- .2 Post notices and take precautions as required by local health authorities. Keep area and premises in sanitary condition.
- .3 When permanent water and drain connections are completed, provide temporary water closets and urinals complete with temporary enclosures, inside building. Permanent facilities may be used on approval of Engineer/Architect.

1.9 REMOVAL OF TEMPORARY FACILITIES

- .1 Remove temporary facilities from site when directed by Engineer/Architect.
- .2 When project is closed down at end of construction season keep temporary facilities operational until close down or removal is approved by Engineer/Architect.

PART 2 - PRODUCTS (NOT APPLICABLE)

PART 3 - EXECUTION (NOT APPLICABLE)

END OF SECTION

PART 1 - GENERAL

1.1 SECTION INCLUDES

- .1 Construction aids.
- .2 Parking.
- .3 Project identification.

1.2 RELATED SECTIONS

- .1 Section 01 51 00 – Temporary Utilities.
- .2 Section 01 56 00 – Temporary Barriers and Enclosures.

1.3 INSTALLATION AND REMOVAL

- .1 Provide construction facilities in order to execute Work expeditiously.
- .2 Remove from site all such work after use.

1.4 SCAFFOLDING

- .1 Provide and maintain scaffolding in rigid, secure and safe manner.
- .2 Erect scaffolding independent of walls. Remove promptly when no longer required. Refer to Section 01 35 29.06 – Health and Safety Requirements for scaffolding requirements.

1.5 HOISTING

- .1 Provide, operate and maintain hoists cranes required for moving of workers, materials and equipment. Make financial arrangements with Subcontractors for use thereof.
- .2 Hoists cranes shall be operated by qualified operator.

1.6 SITE STORAGE/LOADING

- .1 Confine work and operations of employees by Contract Documents. Do not unreasonably encumber premises with products.
- .2 Do not load or permit to load any part of Work with a weight or force that will endanger the Work.

1.7 CONSTRUCTION PARKING

- .1 Parking is permitted as per University parking policy.
- .2 Provide and maintain adequate access to project site.

- .3 Build and maintain temporary roads where indicated or directed by Engineer/Architect and provide snow removal during period of Work.
- .4 If authorized to use existing roads for access to project site, maintain such roads for duration of Contract and make good damage resulting from Contractors' use of roads.

1.8 EQUIPMENT, TOOL AND MATERIALS STORAGE

- .1 Provide and maintain, in a clean and orderly condition, lockable weatherproof sheds for storage of tools, equipment and materials.
- .2 Locate materials not required to be stored in weatherproof sheds on site in a manner to cause least interference with work activities.

PART 2 - PRODUCTS (NOT APPLICABLE)

PART 3 - EXECUTION (NOT APPLICABLE)

END OF SECTION

PART 1 - GENERAL

1.1 SECTION INCLUDES

- .1 Barriers.
- .2 Environmental Controls.
- .3 Traffic Controls.
- .4 Fire Routes.

1.2 RELATED SECTIONS

- .1 Sections 01 51 00 – Temporary Utilities.
- .2 Section 01 52 00 – Construction Facilities.

1.3 INSTALLATION AND REMOVAL

- .1 Provide temporary controls in order to execute Work expeditiously.
- .2 Remove from site all such work after use.

1.4 GUARD RAILS AND BARRICADES

- .1 Provide secure, rigid guard rails and/or barricades around the general work area, excavations, open shafts, open stair wells, open edges of floors and roofs.
- .2 Provide barriers around trees and plants designated to remain. Protect from damage by equipment and construction procedures.
- .3 Provide as required by governing authorities.

1.5 DUST TIGHT SCREENS

- .1 Provide dust tight screens or insulated partitions to localize dust generating activities, and for protection of workers, finished areas of Work and public.
- .2 Maintain and relocate protection until such work is complete.

1.6 ACCESS TO SITE

- .1 Provide and maintain access roads, sidewalk crossings, ramps and construction runways as may be required for access to Work.
- .2 Build and maintain temporary roads where indicated or directed and provide snow removal during period on work.

- .3 If authorized to use existing roads for access to project site, maintain such roads for duration of Contract and make good damage resulting from Contractor's use of roads.

1.7 PUBLIC TRAFFIC FLOW

- .1 Provide and maintain competent signal flag operators, traffic signals, barricades and flares, lights, or lanterns as required to perform Work and protect the public.

1.8 FIRE ROUTES

- .1 Maintain access to property including overhead clearances for use by emergency response vehicles.

1.9 PROTECTION FOR OFF-SITE AND PUBLIC PROPERTY

- .1 Protect surrounding private and public property from damage during performance of Work.
- .2 Be responsible for damage incurred.

PART 2 - PRODUCTS (NOT APPLICABLE)

PART 3 - EXECUTION (NOT APPLICABLE)

END OF SECTION

PART 1 - GENERAL

1.1 RELATED DOCUMENTS

- .1 Drawings and general provisions of the Contract, including General and Supplementary Conditions and other Division 01 Specification Sections, apply to this Section.

1.2 SUMMARY

- .1 Types of items described in this Section:
 - .1 Administrative and procedural requirements for selection of products for use in Project; product delivery, storage, and handling; manufacturers' standard warranties on products; special warranties; and comparable products.
- .2 Types of items you will not find described in this Section:
 - .1 Products selected under an allowance.
 - .2 Procedures for requests for substitutions.
 - .3 Applicable industry standards for products specified.

1.3 DEFINITIONS

- .1 Products: Items obtained for incorporating into the Work, whether purchased for Project or taken from previously purchased stock. The term *product* includes the terms *material*, *equipment*, *system*, and terms of similar intent.
 - .1 Named Products: Items identified by manufacturer's product name, including make or model number or other designation shown or listed in manufacturer's published product literature that is current as of date of the Contract Documents.
 - .2 New Products: Items that have not previously been incorporated into another project or facility. Products salvaged or recycled from other projects are not considered new products.
 - .3 Comparable Product: Product that is demonstrated and approved through submittal process to have the indicated qualities related to type, function, dimension, in-service performance, physical properties, appearance, and other characteristics that equal or exceed those of specified product.
- .2 Basis-of-Design Product Specification: A specification in which a specific manufacturer's product is named and accompanied by the words *basis-of-design product*, including make or model number or other designation, to establish the significant qualities related to type, function, dimension, in-service performance, physical properties, appearance, and other characteristics for purposes of evaluating comparable products of additional manufacturers named in the specification.

1.4 SUBMITTALS

- .1 Comparable Product Requests: Submit request for consideration of each comparable product. Identify product or fabrication or installation method to be replaced. Include Specification Section number and title and Drawing numbers and titles.
 - .1 Include data to indicate compliance with the requirements specified in *Comparable Products Article*.
 - .2 Owner's Representative's Action: If necessary, Owner's Representative will request additional information or documentation for evaluation within one week of receipt of a comparable product request. Owner's Representative will notify Contractor of approval or rejection of proposed comparable product request within 15 days of receipt of request, or seven days of receipt of additional information or documentation, whichever is later.
 - .1 Form of Approval: As specified in Division 01 Section *Submittal Procedures*.

- .2 Use product specified if Owner's Representative does not issue a decision on use of a comparable product request within time allocated.

- .2 Basis-of-Design Product Specification Submittal: Comply with requirements in Division 01 Section *Submittal Procedures*. Show compliance with requirements.

1.5 QUALITY ASSURANCE

- .1 Compatibility of Options: If Contractor is given option of selecting between two or more products for use on Project, select product compatible with products previously selected, even if previously selected products were also options.

1.6 PRODUCT DELIVERY, STORAGE, AND HANDLING

- .1 Deliver, store, and handle products using means and methods that will prevent damage, deterioration, and loss, including theft and vandalism. Comply with manufacturer's written instructions.

- .2 Delivery and Handling:

- .1 Schedule delivery to minimize long-term storage at Project site and to prevent overcrowding of construction spaces.
- .2 Coordinate delivery with installation time to ensure minimum holding time for items that are flammable, hazardous, easily damaged, or sensitive to deterioration, theft, and other losses.
- .3 Deliver products to Project site in an undamaged condition in manufacturer's original sealed container or other packaging system, complete with labels and instructions for handling, storing, unpacking, protecting, and installing.
- .4 Inspect products on delivery to determine compliance with the Contract Documents and to determine that products are undamaged and properly protected.

- .3 Storage:

- .1 Store products to allow for inspection and measurement of quantity or counting of units.
- .2 Store materials in a manner that will not endanger Project structure.
- .3 Store products that are subject to damage by the elements, under cover in a weather tight enclosure above ground, with ventilation adequate to prevent condensation.
- .4 Store foam plastic from exposure to sunlight, except to extent necessary for period of installation and concealment.
- .5 Comply with product manufacturer's written instructions for temperature, humidity, ventilation, and weather-protection requirements for storage.
- .6 Protect stored products from damage and liquids from freezing.
- .7 Provide a secure location and enclosure at Project site for storage of materials and equipment by Owner's construction forces. Coordinate location with Owner.

1.7 PRODUCT WARRANTIES

- .1 Warranties specified in other Sections shall be in addition to, and run concurrent with, other warranties required by the Contract Documents. Manufacturer's disclaimers and limitations on product warranties do not relieve Contractor of obligations under requirements of the Contract Documents.
 - .1 Manufacturer's Warranty: Written warranty furnished by individual manufacturer for a particular product and specifically endorsed by manufacturer to Owner.
 - .2 Special Warranty: Written warranty required by the Contract Documents to provide specific rights for Owner.
- .2 Special Warranties: Prepare a written document that contains appropriate terms and identification, ready for execution.

- .1 Manufacturer's Standard Form: Modified to include Project-specific information and properly executed.
 - .2 Specified Form: When specified forms are included with the Specifications, prepare a written document using indicated form properly executed.
 - .3 Refer to Divisions 02 through 49. Sections for specific content requirements and particular requirements for submitting special warranties.
- .3 Submittal Time: Comply with requirements in Division 01 Section *Closeout Procedures*.

PART 2 - PRODUCTS

2.1 PRODUCT SELECTION PROCEDURES

- .1 General Product Requirements: Provide products that comply with the Contract Documents, are undamaged and, unless otherwise indicated, are new at time of installation.
 - .1 Provide products complete with accessories, trim, finish, fasteners, and other items needed for a complete installation and indicated use and effect.
 - .2 Standard Products: If available, and unless custom products or nonstandard options are specified, provide standard products of types that have been produced and used successfully in similar situations on other projects.
 - .3 Owner reserves the right to limit selection to products with warranties not in conflict with requirements of the Contract Documents.
 - .4 Where products are accompanied by the term *as selected*, Owner's Representative will make selection.
 - .5 Descriptive, performance, and reference standard requirements in the Specifications establish salient characteristics of products.
 - .6 Or Equal: For products specified by name and accompanied by the term *or equal*, or *or approved equal*, or *or approved*, comply with requirements in *Comparable Products* Article to obtain approval for use of an unnamed product.
- .2 Product Selection Procedures:
 - .1 Product: Where Specifications name a single manufacturer and product, provide the named product that complies with requirements. Comparable products or substitutions for Contractor's convenience will not be considered.
 - .2 Manufacturer/Source: Where Specifications name a single manufacturer or source, provide a product by the named manufacturer or source that complies with requirements. Comparable products or substitutions for Contractor's convenience will not be considered.
 - .3 Products:
 - .1 Restricted List: Where Specifications include a list of names of both manufacturers and products, provide one of the products listed that complies with requirements. Comparable products or substitutions for Contractor's convenience may be considered at the sole discretion of the Owner's Representative.
 - .2 Nonrestricted List: Where Specifications include a list of names of both available manufacturers and products, provide one of the products listed, or an unnamed product, that complies with requirements. Comply with requirements in *Comparable Products* Article for consideration of an unnamed product.
 - .4 Manufacturers:
 - .1 Restricted List: Where Specifications include a list of manufacturers' names, provide a product by one of the manufacturers listed that complies with requirements. Comparable products or substitutions for Contractor's convenience may be considered at the sole discretion of the Owner's Representative.
 - .2 Nonrestricted List: Where Specifications include a list of available manufacturers, provide a product by one of the manufacturers listed, or a product by an unnamed manufacturer, that complies with

- requirements. Comply with requirements in *Comparable Products* Article for consideration of an unnamed manufacturer's product.
- .5 Basis-of-Design Product: Where Specifications name a product, or refer to a product indicated on Drawings, and include a list of manufacturers, provide the specified or indicated product or a comparable product by one of the other named manufacturers. Drawings and Specifications indicate sizes, profiles, dimensions, and other characteristics that are based on the product named. Comply with requirements in *Comparable Products* Article for consideration of an unnamed product by one of the other named manufacturers.
 - .3 Visual Matching Specification: Where Specifications require *match Owner's Representative's sample*, provide a product that complies with requirements and matches Owner's Representative's sample. Owner's Representative's decision will be final on whether a proposed product matches.
 - .1 If no product available within specified category matches and complies with other specified requirements, comply with requirements in Division 01 Section *Substitution Procedures* for proposal of product.
 - .4 Visual Selection Specification: Where Specifications include the phrase *as selected by Owner's Representative from manufacturer's full range* or similar phrase, select a product that complies with requirements. Owner's Representative will select color, gloss, pattern, density, or texture from manufacturer's product line that includes both standard and premium items.
- 2.2 COMPARABLE PRODUCTS
- .1 Conditions for Consideration: Owner's Representative will consider Contractor's request for comparable product when the following conditions are satisfied. If the following conditions are not satisfied, Owner's Representative may return requests without action, except to record noncompliance with these requirements:
 - .1 Evidence that the proposed product does not require revisions to the Contract Documents that it is consistent with the Contract Documents and will produce the indicated results, and that it is compatible with other portions of the Work.
 - .2 Detailed comparison of significant qualities of proposed product with those named in the Specifications. Significant qualities include attributes such as performance, weight, size, durability, visual effect, and specific features and requirements indicated.
 - .3 Evidence that proposed product provides specified warranty.
 - .4 List of similar installations for completed projects with project names and addresses and names and addresses of architects and owners, if requested.
 - .5 Samples, if requested.

PART 3 - EXECUTION (Not Used)

END OF SECTION

PART 1 - GENERAL

1.1 GENERAL

- .1 Conduct cleaning and disposal operations to comply with local ordinances and anti-pollution laws.
- .2 Store volatile waste in covered metal containers and remove from premises at end of each working day.
- .3 Provide adequate ventilation during use of volatile or noxious substances. Use of building ventilation systems is not permitted for this purpose.

1.2 RELATED SECTION

- .1 Section 01 77 00 - Closeout Procedures.

1.3 PROJECT CLEANLINESS

- .1 Maintain Work in tidy condition, free from accumulation of waste products and debris, other than that caused by Owner or other Contractors.
- .2 Remove waste materials and debris from site at the end of each working day. Do not burn waste materials on site.
- .3 Clear snow and ice from access to building.
- .4 Make arrangements with and obtain permits from authorities having jurisdiction for disposal of waste and debris.
- .5 Provide on-site containers for collection of waste materials and debris.
- .6 Clean interior areas prior to start of finish work, maintain areas free of dust and other contaminants during finishing operations.
- .7 Store volatile waste in covered metal containers, and remove from premises at end of each working day.
- .8 Provide adequate ventilation during use of volatile or noxious substances. Use of building ventilation systems is not permitted for this purpose.
- .9 Use only cleaning materials recommended by manufacturer of surface to be cleaned, and as recommended by cleaning material manufacturer.
- .10 Schedule cleaning operations so that resulting dust, debris and other contaminants will not fall on wet, newly painted surfaces nor contaminate building systems.

- 1.4 FINAL CLEANING
- .1 Refer to General Conditions.
 - .2 When Work is Substantially Performed, remove surplus products, tools, construction machinery and equipment not required for performance of remaining Work.
 - .3 Remove waste products and debris other than that caused by others, and leave Work clean and suitable for occupancy.
 - .4 When the Work is Totally Performed, remove surplus products, tools, construction machinery and equipment. Remove waste products and debris other than that caused by the Owner or other Contractors.
 - .5 Remove waste materials from the site at regularly scheduled times or dispose of as directed by the Engineer/Architect. Do not burn waste materials on site.
 - .6 Make arrangements with and obtain permits from authorities having jurisdiction for disposal of waste and debris.
 - .7 Leave the work broom clean before the inspection process commences.
 - .8 Clean and polish glass, mirrors, hardware, wall tile, stainless steel, chrome, porcelain enamel, baked enamel, plastic laminate, and mechanical and electrical fixtures. Replace broken, scratched or disfigured glass.
 - .9 Remove stains, spots, marks and dirt from decorative work, electrical and mechanical fixtures, furniture fittings, walls, floors and ceilings.
 - .10 Clean lighting reflectors, lenses, and other lighting surfaces.
 - .11 Vacuum clean and dust building interiors, behind grilles, louvres and screens.
 - .12 Wax, seal, shampoo or prepare floor finishes, as recommended by manufacturer.
 - .13 Inspect finishes, fittings and equipment and ensure specified workmanship and operation.
 - .14 Broom clean and wash exterior walks, steps and surfaces; rake clean other surfaces of grounds.
 - .15 Remove dirt and other disfiguration from exterior surfaces.
 - .16 Clean and sweep roofs.
 - .17 Sweep and wash clean paved areas.
 - .18 Clean equipment and fixtures to a sanitary condition; clean or replace filters of mechanical equipment.
 - .19 Remove snow and ice from access to building.

PART 2 - PRODUCTS (NOT APPLICABLE)

PART 3 - EXECUTION (NOT APPLICABLE)

END OF SECTION

PART 1 - GENERAL

1.1 SUMMARY

- .1 Types of items described in this Section:
 - .1 Requirement to carry out work placing maximum emphasis on the areas of:
 - .1 Waste reduction;
 - .2 Diversion of waste from landfill; and
 - .3 Material Recycling.
 - .2 Types of items you will not find described in this Section:
 - .1 Environment Procedures.

1.2 WASTE MANAGEMENT PLAN

- .1 Prior to commencement of work, prepare waste Management Workplan.
- .2 Workplan to include:
 - .1 Waste audit.
 - .2 Waste reduction practices.
 - .3 Material source separation process.
 - .4 Procedures for sending recyclables to recycling facilities.
 - .5 Procedures for sending non-salvageable items and waste to approved waste processing facility or landfill site.
 - .6 Training and supervising workforce on waste management at site.
- .3 Workplan to incorporate waste management requirements specified herein and in other sections of the Specifications.
- .4 Develop Workplan in collaboration with all subcontractors to ensure all waste management issues and opportunities are addressed.
- .5 Implement and manage all aspects of Waste Management Workplan for duration of work.
- .6 Revise Plan as work progresses addressing new opportunities for diversion of waste from landfill.

1.3 WASTE AUDIT

- .1 At project start-up, conduct waste audit of:
 - .1 Site conditions identifying salvageable and non-salvageable items and waste resulting from demolition and removal work.
 - .2 Projected waste resulting from product packaging and from material leftover after installation work.
- .2 Develop written list. Record type, composition, and quantity of various salvageable items and waste anticipated reasons for waste generation and operational factors which contribute to waste.

1.4 WASTE REDUCTION

- .1 Based on waste audit, develop waste reduction program.

- .2 Structure program to prioritize actions, with waste reduction as first priority, followed by salvage and recycling effort, then disposal as solid waste.
 - .3 Identify materials and equipment to be:
 - .1 Protected and turned over to Owner's Representative when indicated.
 - .2 Salvaged for resale by Contractor.
 - .3 Sent to recycling facility.
 - .4 Sent to waste processing/landfill site for their recycling effort
 - .5 Disposed of in approved landfill site.
 - .4 Reduce construction waste during installation work. Undertake practices which will minimize waste and optimize full use of new materials on site, such as:
 - .1 Use of a central cutting area to allow for easy access to off-cuts;
 - .2 Use of off-cuts for blocking and bridging elsewhere.
 - .3 Use of effective and strategically placed facilities on site for storage and staging of left-over or partially cut materials (such as gypsum board, plywood, ceiling tiles, insulation etc...) to allow for easy incorporation into work whenever possible avoiding unnecessary waste.
 - .5 Develop other strategies and innovative procedures to reduce waste such as minimizing the extent of packaging used for delivery of materials to site etc...
- 1.5 MATERIAL SOURCE SEPARATION PROCESS
- .1 Develop and implement material source separation process at commencement of work as part of mobilization and waste management at site.
 - .2 Provide on-site facilities to collect, handle and store anticipated quantities of reusable, salvageable, and recyclable materials.
 - .1 Use suitable containers for individual collection of items based on intended purpose.
 - .2 Locate to facilitate deposit but without hindering daily operations of existing building tenants.
 - .3 Clearly mark containers and stockpiles as to purpose and use.
 - .3 Perform demolition and removal of existing building components and equipment following a systematic deconstruction process.
 - .1 Separate materials and equipment at source, carefully dismantling, labelling and stockpiling alike items for the following purposes:
 - .1 Reinstallation into the work where indicated.
 - .2 Salvaging reusable items not needed in project which Contractor may sell to other parties. Sale of such items not permitted on site.
 - .3 Sending as many items as possible to locally available recycling facility.
 - .4 Segregating remaining waste and debris into various individual waste categories for disposal in a *non-mixed state* as recommended by waste processing/landfill sites.
 - .4 Isolate product packaging and delivery containers from general waste stream. Send to recycling facility or return to supplier/manufacturer.
 - .5 Send leftover material resulting from installation work for recycling whenever possible.
 - .6 Establish methods whereby hazardous and toxic waste materials, and their containers, encountered or used in the course work are properly isolated, stored on site and disposed in accordance with applicable laws and regulations from authorities having jurisdiction.

- .7 Isolate and store existing materials and equipment identified for re-incorporation into the Work. Protect against damage.

1.6 WORKER TRAINING AND SUPERVISION

- .1 Provide adequate training to workforce, through meetings and demonstrations, to emphasize purpose and worker responsibilities in carrying out the Waste Management Plan.
- .2 Waste Management Coordinator: designate full-time person on site, experienced in waste management and having knowledge of the purpose and content of Waste Management Plan to:
 - .1 Oversee and supervise waste management during work.
 - .2 Provide instructions and directions to all workers and subcontractors on waste reduction, source separation and disposal practices.
- .3 Post a copy of Plan in a prominent location on site for review by workers.

1.7 CERTIFICATION OF MATERIAL DIVERSION

- .1 Submit to Owner's Representative, copies of certified weigh bills from authorized waste processing sites and sale receipts from recycling/reuse facilities confirming receipt of building materials and quantity of waste diverted from landfill.
- .2 Submit data at pre-determined project milestones as determined by Owner's Representative.
- .3 Compare actual quantities diverted from landfill with projections made during waste audit.

1.8 DISPOSAL REQUIREMENTS

- .1 Burying or burning of rubbish and waste materials is prohibited.
- .2 Disposal of waste, volatile materials, mineral spirits, oil, or paint thinner into waterways, storm, or sanitary sewers is prohibited.
- .3 Dispose of waste only at approved waste processing facility or landfill sites approved by authority having jurisdiction.
- .4 Contact the authority having jurisdiction prior to commencement of work, to determine what, if any, demolition and construction waste materials have been banned from disposal in landfills and at transfer stations. Take appropriate action to isolate such banned materials at site of work and dispose in strict accordance with provincial and municipal regulations.
- .5 Transport waste intended for landfill in separated condition, following rules and recommendations of Landfill Operator in support of their effort to divert, recycle and reduce amount of solid waste placed in landfill.
- .6 Collect, bundle and transport salvaged materials to be recycled in separated categories and condition as directed by recycling facility. Ship materials only to approved recycling facilities.
- .7 Sale of salvaged items by Contractor to other parties not permitted on site.

END OF SECTION

PART 1 - GENERAL

1.1 RELATED DOCUMENTS

- .1 Drawings and general provisions of the Contract, including General and Supplementary Conditions and other Division 01 Specification Sections, apply to this Section.

1.2 SUMMARY

- .1 Types of items described in this Section:
 - .1 Administrative and procedural requirements for contract closeout, including, but not limited to, the following:
 - .1 Substantial Completion procedures.
 - .2 Final completion procedures.
 - .3 Warranties.
 - .4 Final cleaning.
 - .2 Types of items you will not find described in this Section:
 - .1 Submitting final completion construction photographic documentation.
 - .2 Progress cleaning of project site.
 - .3 Operation and maintenance manual requirements.
 - .4 Submitting record drawings, record specifications, and record product data.
 - .5 Requirements for instructing owner's personnel.
 - .6 Divisions 02 through 49 sections for specific closeout and special cleaning requirements for the work in those Sections.

1.3 SUBSTANTIAL COMPLETION

- .1 Preliminary Procedures: Before requesting inspection for determining date of Substantial Completion, complete the following. List items below that are incomplete with request.
 - .1 Prepare a list of items to be completed and corrected (punch list), the value of items on the list, and reasons why the Work is not complete.
 - .2 Advise Owner of pending insurance changeover requirements.
 - .3 Submit specific warranties, workmanship bonds, maintenance service agreements, final certifications, and similar documents.
 - .4 Obtain and submit releases permitting Owner unrestricted use of the Work and access to services and utilities. Include occupancy permits, operating certificates, and similar releases.
 - .5 Prepare and submit Project Record Documents, operation and maintenance manuals, damage or settlement surveys, property surveys, and similar final record information.
 - .6 Deliver tools, spare parts, extra materials, and similar items to location designated by Owner. Label with manufacturer's name and model number where applicable.
 - .7 Make final changeover of permanent locks and deliver keys to Owner. Advise Owner's personnel of changeover in security provisions.
 - .8 Complete startup testing of systems.
 - .9 Submit test/adjust/balance records.
 - .10 Terminate and remove temporary facilities from Project site, along with mockups, construction tools, and similar elements.
 - .11 Advise Owner of changeover in heat and other utilities.
 - .12 Submit changeover information related to Owner's occupancy, use, operation, and maintenance.
 - .13 Complete final cleaning requirements, including touchup painting.
 - .14 Touch up and otherwise repair and restore marred exposed finishes to eliminate visual defects.

- .15 Instruct Owner's personnel in operation, adjustment, and maintenance of products, equipment, and systems.
 - .2 Inspection: Submit a written request for inspection for Substantial Completion. On receipt of request, Owner's Representative will either proceed with inspection or notify Contractor of unfulfilled requirements. Owner's Representative will prepare the Certificate of Substantial Completion after inspection or will notify Contractor of items, either on Contractor's list or additional items identified by Owner's Representative that must be completed or corrected before certificate will be issued.
 - .1 Reinspection: Request reinspection when the Work identified in previous inspections as incomplete is completed or corrected.
 - .2 Results of completed inspection will form the basis of requirements for final completion.
- 1.4 FINAL COMPLETION
- .1 Preliminary Procedures: Before requesting final inspection for determining final completion, complete the following:
 - .1 Submit a final Application for Payment according to Division 01 Section *Payment Procedures*.
 - .2 Submit certified copy of Owner's Representative's Substantial Completion inspection list of items to be completed or corrected (punch list), endorsed and dated by Owner's Representative. The certified copy of the list shall state that each item has been completed or otherwise resolved for acceptance.
 - .2 Inspection: Submit a written request for final inspection for acceptance. On receipt of request, Owner's Representative will either proceed with inspection or notify Contractor of unfulfilled requirements. Owner's Representative will prepare a final Certificate for Payment after inspection or will notify Contractor of construction that must be completed or corrected before certificate will be issued.
 - .1 Reinspection: Request reinspection when the Work identified in previous inspections as incomplete is completed or corrected.
- 1.5 LIST OF INCOMPLETE ITEMS (PUNCH LIST)
- .1 Organization of List: Include name and identification of each space and area affected by construction operations for incomplete items and items needing correction including, if necessary, areas disturbed by Contractor that are outside the limits of construction.
 - .1 Organize list of spaces in sequential order, starting with exterior areas first and proceeding from lowest floor to highest floor.
 - .2 Organize items applying to each space by major element, including categories for ceiling, individual walls, floors, equipment, and building systems.
 - .3 Include the following information at the top of each page:
 - .1 Project name.
 - .2 Date.
 - .3 Name of Owner's Representative.
 - .4 Name of Contractor.
 - .5 Page number.
 - .4 Submit list of incomplete items in the following format:
 - .1 Three paper copies of product schedule or list, unless otherwise indicated.
- 1.6 WARRANTIES
- .1 Submittal Time: Submit written warranties on request of Owner's Representative for designated portions of the Work where commencement of warranties other than date of Substantial Completion is indicated.
 - .2 Organize warranty documents into an orderly sequence based on the table of contents of the Project Manual.

- .1 Bind warranties and bonds in heavy-duty, three-ring, vinyl-covered, loose-leaf binders, thickness as necessary to accommodate contents, and sized to receive 215-by-280-mm paper.
 - .2 Provide heavy paper dividers with plastic-covered tabs for each separate warranty. Mark tab to identify the product or installation. Provide a typed description of the product or installation, including the name of the product and the name, address, and telephone number of Installer.
 - .3 Identify each binder on the front and spine with the typed or printed title *WARRANTIES*, Project name, and name of Contractor.
- .3 Provide additional copies of each warranty to include in operation and maintenance manuals.

PART 2 - PRODUCTS

2.1 MATERIALS

- .1 Cleaning Agents: Use cleaning materials and agents recommended by manufacturer or fabricator of the surface to be cleaned. Do not use cleaning agents that are potentially hazardous to health or property or that might damage finished surfaces.
 - .1 Use cleaning products that meet Green Seal GS-37, or if GS-37 is not applicable, use products that comply with the California Code of Regulations maximum allowable VOC levels.

PART 3 - EXECUTION

3.1 FINAL CLEANING

- .1 General: Perform final cleaning. Conduct cleaning and waste-removal operations to comply with local laws and ordinances and Federal and local environmental and antipollution regulations.
- .2 Cleaning: Employ experienced workers or professional cleaners for final cleaning. Clean each surface or unit to condition expected in an average commercial building cleaning and maintenance program. Comply with manufacturer's written instructions.
 - .1 Complete the following cleaning operations, as applicable to the project, before requesting inspection for certification of Substantial Completion for entire Project or for a portion of Project:
 - .1 Clean Project site, yard, and grounds, in areas disturbed by construction activities, including landscape development areas, of rubbish, waste material, litter, and other foreign substances.
 - .2 Sweep paved areas broom clean. Remove petrochemical spills, stains, and other foreign deposits.
 - .3 Rake grounds that are neither planted nor paved to a smooth, even-textured surface.
 - .4 Remove tools, construction equipment, machinery, and surplus material from Project site.
 - .5 Remove snow and ice to provide safe access to building.
 - .6 Clean exposed exterior and interior hard-surfaced finishes to a dirt-free condition, free of stains, films, and similar foreign substances. Avoid disturbing natural weathering of exterior surfaces. Restore reflective surfaces to their original condition.
 - .7 Remove debris and surface dust from limited access spaces, including roofs, plenums, shafts, trenches, equipment vaults, manholes, attics, and similar spaces.
 - .8 Sweep concrete floors broom clean in unoccupied spaces.
 - .9 Vacuum carpet and similar soft surfaces, removing debris and excess nap; shampoo if visible soil or stains remain.
 - .10 Clean transparent materials, including mirrors and glass in doors and windows. Remove glazing compounds and other noticeable, vision-obscuring materials. Replace chipped or broken glass and other damaged transparent materials. Polish mirrors and glass, taking care not to scratch surfaces.
 - .11 Remove labels that are not permanent.

- .12 Touch up and otherwise repair and restore marred, exposed finishes and surfaces. Replace finishes and surfaces that cannot be satisfactorily repaired or restored or that already show evidence of repair or restoration.
 - .1 Do not paint over *ULC* and other required labels and identification, including mechanical and electrical nameplates.
 - .13 Wipe surfaces of mechanical and electrical equipment, elevator equipment, and similar equipment. Remove excess lubrication, paint and mortar droppings, and other foreign substances.
 - .14 Replace parts subject to operating conditions during construction that may impede operation or reduce longevity.
 - .15 Clean plumbing fixtures to a sanitary condition, free of stains, including stains resulting from water exposure.
 - .16 Replace disposable air filters and clean permanent air filters. Clean exposed surfaces of diffusers, registers, and grills.
 - .17 Clean ducts, blowers, and coils if units were operated without filters during construction or that display contamination with particulate matter upon inspection.
 - .1 Clean HVAC system in compliance with NADCA Standard 1992-01. Provide written report upon completion of cleaning upon request.
 - .18 Clean light fixtures, lamps, globes, and reflectors to function with full efficiency. Replace burned-out bulbs, and those noticeably dimmed by hours of use, and defective and noisy starters in fluorescent and mercury vapor fixtures to comply with requirements for new fixtures.
 - .19 Leave Project clean and ready for occupancy.
 - .20 If final cleaning is not to a standard acceptable to the owner, the owner, with prior notice to the contractor, may opt to have owners cleaning staff perform final cleaning at a cost to the contractor. Full owner burden rates will apply.
- .3 Pest Control: Engage an experienced, licensed exterminator to make a final inspection and rid Project of rodents, insects, and other pests if pest problems are suspected by the Owner's Representative. Prepare a report.
- .4 Construction Waste Disposal: Comply with waste disposal requirements in Division 01 Section *Construction Waste Management and Disposal*.

END OF SECTION

PART 1 - GENERAL

1.1 RELATED DOCUMENTS

- .1 Drawings and general provisions of the Contract, including General and Supplementary Conditions and other Division 01 Specification Sections, apply to this Section.

1.2 SUMMARY

- .1 Types of items described in this Section:
 - .1 Administrative and procedural requirements for project record documents, including the following:
 - .1 Record Drawings.
- .2 Types of items you will not find described in this Section:
 - .1 Record specifications.
 - .2 Record product data.
 - .3 Miscellaneous record submittals.
 - .4 Final property survey.
 - .5 General closeout procedures.
 - .6 Operation and maintenance manual requirements.

1.3 CLOSEOUT SUBMITTALS

- .1 Record Drawings: Comply with the following:
 - .1 Number of Copies: Submit two set(s) of marked-up record prints.

PART 2 - PRODUCTS

2.1 RECORD DRAWINGS

- .1 Record Prints: Maintain one set of marked-up paper copies of the Contract Drawings and Shop Drawings.
 - .1 Preparation: Mark record prints to show the actual installation where installation varies from that shown originally. Require individual or entity who obtained record data, whether individual or entity is Installer, subcontractor, or similar entity, to provide information for preparation of corresponding marked-up record prints.
 - .1 Give particular attention to information on concealed elements that would be difficult to identify or measure and record later.
 - .2 Accurately record information in an acceptable drawing technique.
 - .3 Record data as soon as possible after obtaining it.
 - .4 Record and check the markup before enclosing concealed installations.
 - .5 Cross-reference record prints to corresponding archive photographic documentation.
 - .2 Content: Types of items requiring marking include, but are not limited to, the following:
 - .1 Dimensional changes to Drawings.
 - .2 Revisions to details shown on Drawings.
 - .3 Depths of foundations below first floor.
 - .4 Locations and depths of underground utilities.
 - .5 Revisions to routing of piping and conduits.
 - .6 Revisions to electrical circuitry.
 - .7 Actual equipment locations.
 - .8 Duct size and routing.

- .9 Locations of concealed internal utilities.
 - .10 Changes made by Change Order or Construction Change Directive.
 - .11 Changes made following Owner's Representative's written orders.
 - .12 Details not on the original Contract Drawings.
 - .13 Field records for variable and concealed conditions.
 - .14 Record information on the Work that is shown only schematically.
 - .3 Mark the Contract Drawings and Shop Drawings completely and accurately. Utilize personnel proficient at recording graphic information in production of marked-up record prints.
 - .4 Mark record sets with erasable, red-coloured pencil. Use other colors to distinguish between changes for different categories of the Work at same location.
 - .5 Mark important additional information that was either shown schematically or omitted from original Drawings.
 - .6 Note Construction Change Directive numbers, alternate numbers, Change Order numbers, and similar identification, where applicable.
- .2 Format: Identify and date each record Drawing; include the designation "PROJECT RECORD DRAWING" in a prominent location.

PART 3 - EXECUTION

3.1 RECORDING AND MAINTENANCE

- .1 Maintenance of Record Documents and Samples: Store record documents and Samples in the field office apart from the Contract Documents used for construction. Do not use project record documents for construction purposes. Maintain record documents in good order and in a clean, dry, legible condition, protected from deterioration and loss. Provide access to project record documents for Owner's Representative's reference during normal working hours.

END OF SECTION

PART 1 - GENERAL

1.1 SECTIONS INCLUDES

- .1 Methods and procedures for demolishing, salvaging, recycling and removing site work items designated to be removed in whole or in part, and for backfilling resulting trenches and excavations.

1.2 RELATED SECTIONS

- .1 Section 01 33 00 – Submittal Procedures
- .2 Section 01 45 00 - Quality Control
- .3 Section 01 35 43 - Environmental Procedures
- .4 Section 01 35 29.06 - Health and Safety Requirements

1.3 SUBMITTALS

- .1 Submittals in accordance with Section 01 33 00 - Submittal Procedures.
- .2 Shop drawings
 - .1 Submit for approval drawings, diagrams or details showing sequence of demolition work and supporting structures and underpinning, where required by authorities having jurisdiction.
 - .2 Submit drawings stamped and signed by qualified professional engineer registered or licensed in Province of Newfoundland and Labrador, Canada.
- .3 Hazardous Materials: provide description of Hazardous Materials and Notification of Filing with proper authorities prior to beginning of Work as required.

1.4 STORAGE AND PROTECTION

- .1 Perform all work in accordance with Section 01 35 43 - Environmental Procedures
- .2 Protect in accordance with Section 31 23 10 – Excavating, Trenching and Backfilling.
- .3 Protect existing items designated to remain and items designated for salvage. In event of damage to such items, immediately replace or make repairs to approval of Engineer/Architect and at no cost to Engineer/Architect.
- .4 In all circumstances ensure that demolition work does not adversely affect adjacent water courses groundwater and wildlife, or contribute to excess air and noise pollution.
- .5 Do not dispose, of waste or volatile materials such as mineral spirits, oil, petroleum based lubricants, or toxic cleaning solutions into watercourses, storm or sanitary sewers. Ensure proper disposal procedures are maintained throughout project.
- .6 Do not pump water containing suspended materials into watercourses, storm or sanitary sewers, or onto adjacent properties.

- .7 Control disposal or runoff of water containing suspended materials or other harmful substances in accordance with local authorities.
- .8 Protect trees, plants and foliage on site and adjacent properties where indicated.

1.5 EXISTING CONDITIONS

- .1 Prior to start of any demolition work remove contaminated or hazardous materials as defined by authorities having jurisdiction from site and dispose of at designated disposal facilities

PART 2 - PRODUCTS (NOT APPLICABLE)

PART 3 - EXECUTION

3.1 PREPARATION

- .1 Inspect site with Engineer/Architect and verify extent and location of items designated for removal, disposal, alternative disposal, recycling, salvage and items to remain.
- .2 Locate and protect utilities. Preserve active utilities traversing site in operating condition.
- .3 Notify and obtain approval of utility companies before starting demolition.

3.2 REMOVAL OPERATIONS

- .1 Remove items as indicated.
- .2 Do not disturb items designated to remain in place.
- .3 Removal of Pavements, Curbs and Gutters
 - .1 Square up adjacent surfaces to remain in place by saw cutting or other method approved by Engineer/Architect.
 - .2 Protect adjacent joints and load transfer devices.
 - .3 Protect underlying and adjacent granular material.
- .4 When removing asphalt pavement for subsequent incorporation into hot mix asphalt concrete paving, prevent contamination with base course aggregates.
- .5 When removing pipes under existing or future pavement area, excavate at least 300mm below pipe invert.
- .6 Decommission water wells and monitoring wells in accordance with Provincial guidelines and regulations.
- .7 Removal from site
 - .1 Interim removal of stockpiled material will be required by Engineer/Architect, if it is deemed to interfere with operations of Engineer/Architect or other contractors.
- .8 Sealing
 - .1 Seal pipe ends and walls of manholes or catch basins as indicated. Securely plug to form watertight seal.

- .9 Backfill
 - .1 Backfill in areas as indicated and in accordance with Section 31 23 10 - Excavating, Trenching and Backfilling.

- 3.3 RESTORATION
 - .1 Restore areas and existing works outside areas of demolition to match conditions of adjacent, undisturbed areas.
 - .2 Use soil treatments and procedures which are not harmful to health, are not injurious to plants, and do not endanger wildlife, adjacent water courses or ground water.

- 3.4 CLEAN UP
 - .1 Upon completion of work, remove debris, trim surfaces and leave work site clean.
 - .2 Use cleaning solutions and procedures which are not harmful to health, are not injurious to plants, and do not endanger wildlife, adjacent water courses or ground water.

END OF SECTION

PART 1 - GENERAL

1.1 RELATED SECTIONS

- .1 Section 01 74 19 – Construction/Demolition Waste Management And Disposal.
- .2 Section 03 20 00 – Concrete Reinforcing.
- .3 Section 03 30 00 – Cast-in-Place Concrete.

1.2 REFERENCES

- .1 Codes and Standards referenced in this section refers to the latest edition thereof.
- .2 Canadian Standards Association (CSA)
 - .1 CAN/CSA-A23.1, Concrete Materials and Methods of Concrete Construction.
 - .2 CAN/CSA-O86.1, Engineering Design in Wood (Limit States Design).
 - .3 CSA O121, Douglas Fir Plywood.
 - .4 CSA O151, Canadian Softwood Plywood.
 - .5 CSA S269.1, Falsework for Construction Purposes.
 - .6 CAN/CSA-S269.3, Concrete Formwork.

1.3 SUBMITTALS

- .1 Submit shop drawings for formwork and falsework in accordance with Section 01330 • Submittal Procedures.
- .2 Indicate method and schedule of construction, shoring, stripping and re-shoring procedures, materials, arrangement of joints, special architectural exposed finishes, ties, liners, and locations of temporary embedded parts. Comply with CSA S269.1, for falsework drawings. Comply with CAN/CSA-S269.3, for formwork drawings.
- .3 Indicate formwork design data, such as permissible rate of concrete placement, and temperature of concrete, in forms.
- .4 Indicate sequence of erection and removal of formwork/falsework as directed by Engineer/Architect.
- .5 Each shop drawing submission shall bear stamp and signature of qualified professional engineer registered or licensed in Province of Newfoundland and Labrador, Canada.

PART 2 - PRODUCTS

2.1 MATERIALS

- .1 Formwork materials:
 - .1 For concrete without special architectural features, use wood and wood product formwork materials to CSA-O121.
 - .2 For concrete with special architectural features, use formwork materials to CAN/CSA-A23.1.

- .2 Tubular column forms: round, spirally wound laminated fiber forms, internally treated with release material. Spiral pattern to show in hardened concrete.
- .3 Form ties:
 - .1 For concrete not designated 'Architectural', use removable or snap-off metal ties, fixed or adjustable length, free of devices leaving holes larger than 25 mm dia. in concrete surface.
 - .2 For Architectural concrete, use snap ties complete with plastic cones and light grey concrete plugs.
- .4 Form liner:
 - .1 Plywood: medium density overlay Douglas Fir to CSA O121, Canadian Softwood Plywood to CSA O151, T and G thickness as indicated.
- .5 Form release agent: chemically active release agents containing compounds that react with free lime in concrete resulting in water insoluble soaps, non-toxic, biodegradable.
- .6 Falsework materials: to CSA-S269.1.
- .7 Sealant: to Section 07 92 10 – Joint Sealing.

PART 3 - EXECUTION

3.1 FABRICATION AND ERECTION

- .1 Verify lines, levels and centres before proceeding with formwork/falsework and ensure dimensions agree with drawings.
- .2 Fabricate and erect falsework in accordance with CSA S269.1.
- .3 Refer to architectural drawings for concrete members requiring architectural exposed finishes.
- .4 Do not place shores and mud sills on frozen ground.
- .5 Provide site drainage to prevent washout of soil supporting mud sills and shores.
- .6 Fabricate and erect formwork in accordance with CAN/CSA-S269.3, Latest Edition, to produce finished concrete conforming to shape, dimensions, locations and levels indicated within tolerances required by CAN/CSA-A23.1.
- .7 Align form joints and make watertight. Keep form joints to minimum.
- .8 Locate horizontal form joints for exposed columns 2400 mm above finished floor elevation.
- .9 Use 25 mm chamfer strips on external corners and/or 25 mm fillets at interior corners, joints, unless specified otherwise.
- .10 Form chases, slots, openings, drips, recesses, expansion and control joints as indicated.
- .11 Construct forms for architectural concrete, and place ties as indicated and/or as directed. Joint pattern not necessarily based on using standard size panels or maximum permissible spacing of ties.

- .12 Build in anchors, sleeves, and other inserts required to accommodate Work specified in other sections. Assure that all anchors and inserts will not protrude beyond surfaces designated to receive applied finishes, including painting.
- .13 Clean formwork in accordance with CAN/CSA-A23.1, before placing concrete.

3.2 REMOVAL AND RESHORING

- .1 Leave formwork in place for following minimum periods of time after placing concrete.
 - .1 3 days for walls and sides of beams.
 - .2 5 days for columns.
 - .3 1 day for footings and abutments.
- .2 Provide all necessary reshoring of members where early removal of forms may be required or where members may be subjected to additional loads during construction as required.
- .3 Space reshoring in each principal direction at not more than 3000 mm apart.
- .4 Re-use formwork and falsework subject to requirements of CAN/CSA-A23.1.

END OF SECTION

PART 1 - GENERAL

1.1 RELATED SECTIONS

- .1 Section 01 74 19 – Construction/Demolition Waste Management And Disposal.
- .2 Section 03 10 00 – Concrete Forming and Accessories.
- .3 Section 03 30 00 – Cast-in-Place Concrete.

1.2 REFERENCES

- .1 Codes and Standards referenced in this section refers to the latest edition thereof.
- .2 ACI 315R, Manual of Engineering and Placing Drawings for Reinforced Concrete Structure.
- .3 CAN/CSA-A23.1, Concrete Materials and Methods of Concrete Construction.
- .4 CAN3-A23.3, Design of Concrete Structures for Buildings.
- .5 CSA G30.3, Cold Drawn Steel Wire for Concrete Reinforcement.
- .6 CSA G30.5, Welded Steel Wire Fabric for Concrete Reinforcement.
- .7 CAN/CSA-G30.18, Billet-Steel Bars for Concrete Reinforcement.
- .8 CSA G30.14, Welded Deformed Steel Wire for Concrete Reinforcement.
- .9 CAN/CSA-G40.21, Structural Quality Steels.
- .10 CAN/CSA-G164, Hot Dip Galvanizing of Irregularly Shaped Articles.
- .11 CSA W186-, Welding of Reinforcing Bars in Reinforced Concrete Construction.
- .12 ANSI/ACI 315, Details and Detailing of Concrete Reinforcement.

1.3 SHOP DRAWINGS

- .1 Submit shop drawings including placing of reinforcement in accordance with Section 01 33 00 - Submittal Procedures.
- .2 Indicate on shop drawings, bar bending details, lists, quantities of reinforcement, sizes, spacings, locations of reinforcement and mechanical splices if approved by Engineer/Architect, with identifying code marks to permit correct placement without reference to structural drawings. Indicate sizes, spacings and locations of chairs, spacers and hangers. Prepare reinforcement drawings in accordance with Reinforcing Steel Manual of Standard Practice - b y Reinforcing Steel Institute of Canada. ANSI/ACI 315 and ACI 315R, Manual of Engineering and Placing Drawings for Reinforced Concrete Structure.
- .3 Detail lap lengths and bar development lengths to CAN3-A23.3, unless otherwise indicated.

PART 2 - PRODUCTS

2.1 MATERIALS

- .1 Substitute different size bars only if permitted in writing by Engineer/Architect.
- .2 Reinforcing steel: billet steel, grade 400, deformed bars to CAN/CSA-G30.18, unless indicated otherwise.
- .3 Cold-drawn annealed steel wire ties: to CSA G30.3,
- .4 Welded steel wire fabric: to CSA G30.5. Provide in flat sheets only.
- .5 Chairs, bolsters, bar supports, spacers: to CAN/CSA-A23.1.
- .6 Mechanical splices: subject to approval of Engineer/Architect.
- .7 Plain round bars: to CAN/CSA-G40.21.

2.2 FABRICATION

- .1 Fabricate reinforcing steel in accordance with CAN/CSA-A23.1, ANSI/ACI 315, Latest Edition and Reinforcing Steel Manual of Standard Practice by the Reinforcing Steel Institute of Canada.
- .2 Obtain Engineer's/Architect approval for locations of reinforcement splices other than those shown on placing drawings.
- .3 Upon approval of Engineer/Architect, weld reinforcement in accordance with CSA W186.
- .4 Ship bundles of bar reinforcement, clearly identified in accordance with bar bending details and lists.

2.3 SOURCE QUALITY CONTROL

- .1 Upon request, provide Engineer/Architect with certified copy of mill test report of reinforcing steel, showing physical and chemical analysis, minimum 4 weeks prior to commencing reinforcing work.
- .2 Upon request inform Engineer/Architect of proposed source of material to be supplied.

PART 3 - EXECUTION

3.1 FIELD BENDING

- .1 Do not field bend or field weld reinforcement except where indicated or authorized by Engineer/Architect.
- .2 When field bending is authorized, bend without heat, applying a slow and steady pressure.
- .3 Replace bars which develop cracks or splits.

3.2 PLACING REINFORCEMENT

- .1 Place reinforcing steel as indicated on reviewed placing drawings and in accordance with CAN/CSA-A23.1.

- .2 Use plain round bars as slip dowels in concrete. Paint portion of dowel intended to move within hardened concrete with one coat of asphalt paint. When paint is dry, apply a thick even film of mineral lubricating grease.
- .3 Prior to placing concrete, obtain Engineer/Architect approval of reinforcing material and placement.
- .4 Ensure cover to reinforcement is maintained during concrete pour.

END OF SECTION

PART 1 - GENERAL

1.1 RELATED SECTIONS

- .1 Section 01 74 19 – Construction/Demolition Waste Management And Disposal
- .2 Section 03 10 00 – Concrete Forming and Accessories.
- .3 Section 03 20 00 – Concrete Reinforcing
- .4 Section 03 35 05 – Concrete Floor Hardeners.
- .5 Section 03 35 00 – Concrete Finishing.

1.2 MEASUREMENT PROCEDURES

- .1 Cast-in-place concrete will not be measured but will be paid for as a fixed price item.

1.3 REFERENCES

- .1 Codes and Standards referenced in this section refers to the latest edition thereof.
- .2 ASTM C260, Specification for Air-entraining Admixtures for Concrete.
- .3 ASTM C309, Specification for Liquid Membrane-Forming Compounds for Curing Concrete.
- .4 ASTM C494, Specification for Chemical Admixtures for Concrete.
- .5 ASTM D1751, Specification for Preformed Expansion Joint Fillers for Concrete Paving and Structural Construction (No extruding and Resilient Bituminous Types).
- .6 CAN/CGSB-51.34, Vapor Barrier, Polyethylene Sheet for Use in Building Construction.
- .7 CAN/CSA-A5, Portland Cement.
- .8 CAN/CSA-A23.1, Concrete Materials and Methods of Concrete Construction.
- .9 CAN/CSA-A23.2, Methods of Test for Concrete.
- .10 CAN3-A266.4, Guidelines for the Use of Admixtures in concrete.

1.4 SAMPLES

- .1 Submit samples in accordance with Section 01 33 00 – Submittal Procedures.
- .2 At least 4 weeks prior to commencing work, inform Engineer/Architect of proposed source of aggregates and provide access for sampling.

1.5 CERTIFICATES

- .1 Submit certificates in accordance with Section 01 33 00 – Submittal Procedures.

- .2 Minimum 4 weeks prior to starting concrete work submit to Engineer/Architect manufacturer's test data and certification by qualified independent inspection and testing laboratory that following materials will meet specified requirements:
 - .1 Portland cement.
 - .2 Blended hydraulic cement.
 - .3 Supplementary cementing materials.
 - .4 Grout.
 - .5 Admixtures.
 - .6 Aggregates.
 - .7 Water.
 - .8 Waterstops.
 - .9 Waterstop joints.
 - .10 Joint filler.
 - .3 Provide certification that mix proportions selected will produce concrete of quality, yield and strength as specified in concrete mixes, and will comply with CAN/CSA-A23.1.
 - .4 Provide certification that plant, equipment, and materials to be used in concrete comply with requirements of CAN/CSA-A23.1.
- 1.6 SOURCE QUALITY CONTROL
- .1 Have all concrete produced and delivered by a ready-mix plant that is a member of the Atlantic Provinces Ready Mixed Concrete Association (APRMCA) and holds a current "Certificate of Ready Mixed Concrete Production Facilities" issued by the Association. Submit a copy of this certificate to the Engineer/Architect for approval.
- 1.7 QUALITY ASSURANCE
- .1 Minimum 4 weeks prior to starting concrete work, submit proposed quality control procedures in accordance with Section 01 45 00 – Quality Control for Engineer's/Architect approval for following items:
 - .1 Falsework erection.
 - .2 Hot weather concrete.
 - .3 Cold weather concrete.
 - .4 Curing.
 - .5 Finishes.
 - .6 Formwork removal.
 - .7 Joints.

PART 2 - PRODUCTS

2.1 MATERIALS

- .1 Portland cement: to CAN/CSA-A5.
- .2 Water: to CAN/CSA-A23.1.
- .3 Aggregates: to CAN/CSA-A23.1. Coarse aggregates to be normal density.

- .4 Air entraining admixture: to ASTM C260.
- .5 Chemical admixtures: to ASTM C494, Engineer/Architect to approve accelerating or set retarding admixtures during cold and hot weather placing.
- .6 Non-premixed dry pack grout: composition of non-metallic aggregate Portland cement with sufficient water for the mixture to retain its shape when made into a ball by hand and capable of developing compressive strength of 50 MPa at 28 days.
- .7 Ribbed waterstops: extruded PVC of sizes indicated shop welded corner and intersecting pieces.
 - .1 Tensile strength: to ASTM D412, method A, Die "C".
 - .2 Elongation: to ASTM D412, method A, Die "C", minimum 275 %.
 - .3 Tear resistance: to ASTM D624, method A, Die "B".
- .8 Pre-molded joint fillers:
 - .1 Bituminous impregnated fiber board: to ASTM D1751.
- .9 Polyethylene film: minimum mm thickness to ASTM C171.
- .10 Bonding adhesive: as approved by Engineer/Architect.

2.2 MIXES

- .1 Proportion normal density concrete in accordance with CAN/CSA-A23.1, Alternative 1 to give following quality and yield for all concrete.
 - .1 Cement:
 - .1 Type 10 Portland cement.
 - .2 Minimum compressive strength at 28 days: 32 MPa, unless otherwise stated on design drawings.
 - .3 Minimum cement content: 300 kg/m³ of concrete.
 - .4 Class of exposure: C-2.
 - .5 Nominal size of coarse aggregate: 20 mm.
 - .6 Slump at time and point of discharge: 75 to 100 mm.
 - .7 Air content: 5 to 8 %.
 - .8 Chemical admixtures: admixtures in accordance with ASTM C494.

PART 3 - EXECUTION

3.1 PREPARATION

- .1 Obtain Engineer's/Architect's approval before placing concrete. Provide 24 h notice prior to placing of concrete.
- .2 Pumping of concrete is permitted only after approval of equipment and mix.
- .3 Ensure reinforcement and inserts are not disturbed during concrete placement.
- .4 Prior to placing of concrete obtain Engineer's/Architect's approval of proposed method for protection of concrete during placing and curing in adverse weather.

- .5 Maintain accurate records of poured concrete items to indicate date, location of pour, quality, air temperature and test samples taken.
- .6 Do not place load upon new concrete until authorized by Engineer/Architect.

3.2 CONSTRUCTION

- .1 Complete cast-in-place concrete work in accordance with CAN/CSA-A23.1.
- .2 Sleeves and inserts.
 - .1 No sleeves, ducts, pipes or other openings shall pass through joists, beams, column capitals or columns, except where indicated or approved by Engineer/Architect.
 - .2 Where approved by Engineer/Architect, set sleeves, ties, pipe hangers and other inserts and openings as indicated or specified elsewhere. Sleeves and openings greater than 100 x 100 mm not indicated, must be approved by Engineer/Architect.
 - .3 Do not eliminate or displace reinforcement to accommodate hardware. If inserts cannot be located as specified, obtain approval of modifications from Engineer/Architect before placing of concrete.
 - .4 Check locations and sizes of sleeves and openings shown on drawings.
 - .5 Set special inserts for strength testing as indicated and as required by non- destructive method of testing concrete.
- .3 Anchor bolts.
 - .1 Set anchor bolts to templates under supervision of appropriate trade prior to placing concrete.
 - .2 With approval of Engineer/Architect, grout anchor bolts in preformed holes or holes drilled after concrete has set. Formed holes to be minimum 100 mm diameter. Drilled holes to be manufacturer's recommendations.
 - .3 Protect anchor bolt holes from water accumulations, snow and ice build-ups.
 - .4 Set bolts and fill holes with shrinkage compensating grout.
 - .5 Locate anchor bolts used in connection with expansion shoes, rollers and rockers with due regard to ambient temperature at time of erection.
- .4 Grout under base plates using procedures in accordance with manufacturer's recommendations which result in 100 % contact over grouted area.
- .5 Finishing.
 - .1 Finish concrete in accordance with CAN/CSA-A23.1.
 - .2 Use procedures acceptable to Engineer/Architect or those noted in CAN/CSA-A23.1, to remove excess bleed water. Ensure surface is not damaged.
 - .3 Wet cure using polyethylene sheets placed over sufficiently hardened concrete to prevent damage. Overlap adjacent edges 150 mm and tightly seal with sand on wood planks. Weigh sheets down to maintain close contact with concrete during the entire curing period.
 - .4 Where burlap is used for moist curing, place two pre-wetted layers on concrete surface and keep continuously wet during curing period.
 - .5 Finish concrete floor to meet requirements of CGSB 81-GP-1M.
 - .6 Concrete floor to have finish hardness equal or greater than Mohs hardness in accordance with CAN/CSA-A23.1.
 - .7 Provide swirl-troweled finish for exterior walks, ramps, pads.
 - .8 Provide float finish for interior floor slabs.

- .9 Rub exposed sharp edges of concrete with carborundum to produce 3 mm radius edges unless otherwise indicated.
- .6 Waterstops.
 - .1 Install waterstops to provide continuous water seal. Do not distort or pierce waterstop in such a way as to hamper performance. Do not displace reinforcement when installing waterstops. Use equipment to manufacturer's requirements to field splice waterstops. Tie waterstops rigidly in place.
 - .2 Use only straight heat sealed butt joints in field. Use factory welded corners and intersections unless otherwise approved by Engineer/Architect.
- .7 Joint fillers.
 - .1 Furnish filler for each joint in single piece for depth and width required for joint, unless otherwise authorized by Engineer/Architect. When more than one piece is required for a joint, fasten abutting ends and hold securely to shape by stapling or other positive fastening.
 - .2 Locate and form, isolation, construction and expansion joints as indicated.
 - .3 Install joint filler.
 - .4 Use 12 mm thick joint filler to separate slabs-on-grade from vertical surfaces and extend joint filler from bottom of slab to within 12 mm of finished slab surface unless indicated otherwise.
- .8 Damp-proof membrane.
 - .1 Install damp-proof membrane under concrete slabs-on-grade inside building.
 - .2 Lap damp-proof membrane minimum 150 mm at joints and seal.
 - .3 Seal punctures in damp-proof membrane before placing concrete. Use patching material at least 150 mm larger than puncture and seal.

3.3 SITE TOLERANCE

- .1 Concrete tolerance in accordance with CAN/CSA-A23.1, straight edge method Ff =30 FI= 20.

3.4 FIELD QUALITY CONTROL

- .1 Inspection and testing of concrete and concrete materials will be carried out by a Testing Laboratory designated by Engineer/Architect in accordance with CAN/CSA-A23.1, and Section 01 45 00 - Quality Control.
- .2 Engineer/Architect will pay for costs of tests as specified in Section 01 29 83 - Payment Procedures: Testing Laboratory Services. Costs of retesting due to deficient work will be paid for by contractor, by credit change order.
- .3 Engineer/Architect will take additional test cylinders during cold weather concreting. Cure cylinders on job site under same conditions as concrete which they represent.
- .4 Non-destructive Methods for Testing Concrete shall be in accordance with CAN/CSA-A23.2.
- .5 Provide Certificate of Field Quality Inspection and Testing to Engineer/Architect for inclusion in Commissioning Manual.
- .6 Inspection or testing by Engineer/Architect will not augment or replace Contractor quality control nor relieve the Contractor of his contractual responsibility.

END OF SECTION

PART 1 - GENERAL

1.1 RELATED DOCUMENTS

- .1 Drawings and general provisions of the Contract, including General and Supplementary Conditions and Division 1 Specification Sections, apply to this Section.

1.2 SUMMARY

- .1 Types of items described in this Section:
 - .1 Fixed-in-Place Steel Pipe Bollards with Covers.

1.3 SUBMITTALS

- .1 Product Data: For each type of bollard cover required.
- .2 Sustainability Submittals:
 - .1 Indicate percentages by weight of postconsumer and preconsumer recycled content for products having recycled content. Include statement indicating costs for each product having recycled content.

PART 2 - PRODUCTS

2.1 FERROUS METALS

- .1 Recycled Content of Steel Products: Provide products with average recycled content of steel products so postconsumer recycled content plus one-half of preconsumer recycled content is not less than 25 percent.
- .2 Pipe: Steel pipe: to ASTM A53/A53M standard weight, black finish.
 - .1 Size: 150 mm diameter unless otherwise noted.

2.2 CONCRETE

- .1 Concrete mixes and materials: in accordance with CAN/CSA-A23.1.
 - .1 Compressive strength: 20 MPa minimum at 28 days.

2.3 BOLLARD COVERS

- .1 Bollard Covers: Smooth, high-impact resistant, UV resistant, one-piece PVC bollard cover with integral dome cap, sized to snugly fit diameter of pipe. Length to suit installation requirements. Minimum of 6 mm wall thickness
 - .1 Colour: safety yellow.

2.4 FABRICATION

- .1 Fabricate metal bollards from steel pipe.
 - .1 Where bollards are indicated to receive push-button controls for door operators, provide necessary cut-outs for push-button controls and hole for wire.

PART 3 - EXECUTION

3.1 INSTALLATION: GENERAL

- .1 Install bollard with top 1500 mm above finished grade, unless otherwise noted.
- .2 Insure bollard cover extends full length of exposed portion of pipe.
- .3 Insure pipe extends down full depth of hole and extends up full height of bollard cover.

3.2 INSTALLATION: FIXED-IN-PLACE STEEL PIPE BOLLARDS WITH COVER

- .1 Mark bollard locations on site and notify Owner's Representative. Adjust locations if so directed by Owner's Representative. Proceed with excavation only after 48 hours from providing notice.
- .2 Take precautions to minimize impact of excavation and placement of concrete on adjacent surfaces. Protect finished surfaces with plywood or similar materials.
- .3 Excavate hole to depth of 1200 mm or to rock-bearing, whichever is lesser. Maintain sides of hole straight and plumb walls whenever possible. Excavate hole 100 mm wider than bollard all around.
- .4 Place pipe in hole in correct position, plumb, level. Adjust height of pipe as may be required to maintain correct height. Fill hole with concrete to within 100 mm of finish grade and allow to set. Fill pipe full with concrete.
- .5 Slide bollard cover over pipe, securing cover in place using construction adhesive.
- .6 Reinstate finish grade with materials to match adjacent grade finish.

END OF SECTION

PART 1 - GENERAL

1.1 RELATED DOCUMENTS

- .1 Drawings and general provisions of the Contract, including General and Supplementary Conditions and Divisions 01 & 7 Specification Sections, apply to this Section.

1.2 SUMMARY

- .1 Types of items described in this Section:
 - .1 Roof tear-off.
 - .2 Removal of base flashings.
- .2 Types of items not described in this Section:
 - .1 Use of the premises and phasing requirements.
 - .2 Temporary construction and environmental-protection measures for reroofing preparation.
 - .3 HVAC equipment removal and reinstallation.
 - .4 Electrical equipment disconnection and reconnection.

1.3 MATERIALS OWNERSHIP

- .1 Except for items or materials indicated to be reused, reinstalled, or otherwise indicated to remain Owner's property, demolished materials shall become Contractor's property and shall be removed from Project site.

1.4 DEFINITIONS

- .1 Roofing Terminology: Refer to ASTM D 1079 and glossary in NRCA's "*The NRCA Roofing and Waterproofing Manual*" for definition of terms related to roofing work in this Section.
- .2 Existing Membrane Roofing System: Visit site for description of existing membrane roofing system. Items included in system, if present, include roofing membrane, roof insulation, surfacing, and components and accessories between deck and roofing membrane.
- .3 Roof Tear-Off: Removal of existing membrane roofing system from deck.
- .4 Remove: Detach items from existing construction and legally dispose of them off-site unless indicated to be removed and reinstalled.
- .5 Existing to Remain: Existing items of construction that are not indicated to be removed.

1.5 QUALITY ASSURANCE

- .1 Installer Qualifications: Any activity related to the roofing/waterproofing of the tunnel is to be carried by an owner approved experienced applicator with a record of at least 5 years of comparable scope completions.
- .2 Reroofing Conference: Conduct conference at Project site.
 - .1 Meet with Owner; Owner's Representative; Owner's insurer if applicable; testing and inspecting agency representative; roofing system manufacturer's representative; deck Installer; roofing Installer including project manager, superintendent, and foreman; and installers whose work interfaces with or affects reroofing including installers of roof accessories and roof-mounted equipment.

- .2 Review methods and procedures related to roofing system tear-off and replacement including, but not limited to, the following:
 - .1 Reroofing preparation, including membrane roofing system manufacturer's written instructions.
 - .2 Temporary protection requirements for existing roofing system that is to remain during and after installation.
 - .3 Existing roof drains and roof drainage during each stage of reroofing, and roof drain plugging and plug removal requirements.
 - .4 Construction schedule and availability of materials, Installer's personnel, equipment, and facilities needed to make progress and avoid delays.
 - .5 Existing deck removal procedures and Owner notifications.
 - .6 Condition and acceptance of existing roof deck and base flashing substrate for reuse.
 - .7 Structural loading limitations of deck during reroofing.
 - .8 Base flashings, special roofing details, drainage, penetrations, equipment curbs, and condition of other construction that will affect reroofing.
 - .9 HVAC shutdown and sealing of air intakes.
 - .10 Shutdown of fire-suppression, -protection, and -alarm and -detection systems.
 - .11 Asbestos removal and discovery of asbestos-containing materials.
 - .12 Governing regulations and requirements for insurance and certificates if applicable.
 - .13 Existing conditions that may require notification of Owner's Representative before proceeding.

1.6 PROJECT CONDITIONS

- .1 Owner will occupy portions of building immediately below reroofing area. Conduct reroofing so Owner's operations will not be disrupted. Provide Owner with not less than 72 hours' notice of activities that may affect Owner's operations.
 - .1 Coordinate work activities daily with Owner so Owner can place protective dust or water leakage covers over sensitive equipment or furnishings, shut down HVAC and fire-alarm or -detection equipment if needed, and evacuate occupants from below the work area.
 - .2 Before working over structurally impaired areas of deck, notify Owner to evacuate occupants from below the affected area. Verify that occupants below the work area have been evacuated before proceeding with work over the impaired deck area.
- .2 Protect building to be reroofed, adjacent buildings, walkways, site improvements, exterior plantings, and landscaping from damage or soiling from reroofing operations.
- .3 Maintain access to existing walkways, corridors, and other adjacent occupied or used facilities.
- .4 Conditions existing at time of inspection for bidding will be maintained by Owner as far as practical.
 - .1 If a roof moisture survey of existing membrane roofing system is available, it will be noted on the drawings, and will be available for Contractor's reference.
 - .2 If the results of an analysis of test cores from existing membrane roofing system are available, it will be noted on the drawings and will be available for Contractor's reference.
- .5 Weather Limitations: Proceed with reroofing preparation only when existing and forecasted weather conditions permit Work to proceed without water entering existing roofing system or building.
- .6 Hazardous Materials: It is not expected that hazardous materials such as asbestos-containing materials will be encountered in the Work.
 - .1 If materials suspected of containing hazardous materials are encountered, do not disturb; immediately notify Owner's Representative and Owner.

PART 2 - PRODUCTS

- .1 Not used.

PART 3 - EXECUTION

3.1 PREPARATION

- .1 Protect existing membrane roofing system that is indicated not to be reroofed.
 - .1 Loosely lay 25 mm minimum thick, moulded expanded polystyrene (MEPS) insulation over the roofing membrane in areas indicated. Loosely lay 12 mm plywood or OSB panels over MEPS. Extend MEPS past edges of plywood or OSB panels a minimum of 25 mm.
 - .2 Limit traffic and material storage to areas of existing roofing membrane that have been protected.
 - .3 Maintain temporary protection and leave in place until replacement roofing has been completed. Remove temporary protection on completion of reroofing.
- .2 Coordinate with Owner to shut down air-intake equipment in the vicinity of the Work. Cover air-intake louvers before proceeding with reroofing work that could affect indoor air quality or activate smoke detectors in the ductwork.
- .3 During removal operations, have sufficient and suitable materials on-site to facilitate rapid installation of temporary protection in the event of unexpected rain.
- .4 Maintain roof drains in functioning condition to ensure roof drainage at end of each workday. Prevent debris from entering or blocking roof drains and conductors. Use roof-drain plugs specifically designed for this purpose. Remove roof-drain plugs at end of each workday, when no work is taking place, or when rain is forecast.
 - .1 If roof drains are temporarily blocked or unserviceable due to roofing system removal or partial installation of new membrane roofing system, provide alternative drainage method to remove water and eliminate ponding. Do not permit water to enter into or under existing membrane roofing system components that are to remain.
- .5 Verify that rooftop utilities and service piping have been shut off before beginning the Work.

3.2 ROOF TEAR-OFF

- .1 General: Notify Owner each day of extent of roof tear-off proposed for that day.
- .2 Remove aggregate ballast from roofing membrane.
- .3 Remove loose aggregate from aggregate-surfaced built-up bituminous roofing using a power broom.
- .4 Remove pavers and accessories from roofing membrane.
- .5 Remove protection mat and extruded-polystyrene insulation from protected roofing membrane.
- .6 Roof Tear-Off: Remove existing roofing membrane and other membrane roofing system components down to the deck.
 - .1 Remove cover boards, roof insulation, and substrate boards, unless otherwise noted on drawings.
 - .2 Bitumen and felts that are firmly bonded to concrete decks are permitted to remain if felts are dry. Remove unadhered bitumen and felts and wet felts.
 - .3 Remove excess asphalt from steel deck. A maximum of 0.72 kg/sq. m of asphalt is permitted to remain on steel decks.

- .4 Remove fasteners from deck or cut fasteners off slightly above deck surface.

3.3 DECK PREPARATION

- .1 Inspect deck after tear-off of membrane roofing system.
- .2 Verify that concrete substrate is visibly dry and free of moisture. Test for capillary moisture by plastic sheet method according to ASTM D 4263 or by pouring 0.5 L of hot roofing asphalt on deck at start of each day's work and at start of each roof area or plane. Do not proceed with roofing work if moisture condenses under the plastic sheet or if asphalt test sample foams or can be easily and cleanly stripped after cooling.
- .3 If broken or loose fasteners that secure deck panels to one another or to structure are observed or if deck appears or feels inadequately attached, immediately notify Owner's Representative. Do not proceed with installation until directed by Owner's Representative.
- .4 If deck surface is not suitable for receiving new roofing or if structural integrity of deck is suspect, immediately notify Owner's Representative. Do not proceed with installation until directed by Owner's Representative.

3.4 EXISTING BASE FLASHINGS

- .1 Remove existing base flashings around parapets, curbs, walls, and penetrations.
 - .1 Clean substrates of contaminants such as asphalt, sheet materials, dirt, and debris.
- .2 Do not damage metal counterflashings that are to remain. Replace metal counterflashings damaged during removal with counterflashings of same metal, weight or thickness, and finish.
- .3 Inspect parapet sheathing for deterioration and damage. If parapet sheathing has deteriorated, immediately notify Owner's Representative.

3.5 DISPOSAL

- .1 Collect demolished materials and place in containers. Promptly dispose of demolished materials. Do not allow demolished materials to accumulate on-site.
 - .1 Storage or sale of demolished items or materials on-site is not permitted.
- .2 Transport and legally dispose of demolished materials off Owner's property.

END OF SECTION .19

PART 1 - GENERAL

1.1 DESCRIPTION OF WORK

- .1 Provide labour, materials, services and equipment necessary to complete the work of this section. Work includes, but is not limited to the following:
 - .1 The complete removal and replacement of the existing modified waterproofing membrane system located on the existing tunnel roof and the associated foundation wall in the areas identified on the drawings.
 - .2 Remove and dispose of the existing modified waterproofing membrane system, and all other related accessories to the limits shown on the drawings.
 - .3 Prepare existing substrates to receive new waterproofing system.
 - .4 Supply and install new 2-ply modified bitumen roof membrane and flashings.
 - .5 Supply and install all material to complete new weathertight tie-ins to adjacent/existing waterproofing membrane system as indicated on the drawings.
 - .6 Supply and install new insulation as indicated on the drawings.
 - .7 Supply and install new moulded-sheet drainage panels/board.
 - .8 Fabricate and install new metal flashing as indicated on the drawings and as defined in Section 07 62 00 – Sheet Metal Flashing and Trim.
 - .9 Perform all other work indicate on the drawings.

1.2 RELATED DOCUMENTS

- .1 Drawings and general provisions of the Contract, including General and Supplementary Conditions and Division 01 Specification Sections, apply to this Section.

1.3 DEFINITIONS

- .1 Roofing Terminology: Refer to ASTM D 1079 and glossary of NRCA's *The NRCA Roofing and Waterproofing Manual* for definition of terms related to roofing work in this Section.

1.4 SUBMITTALS

- .1 Product Data: Include manufacturer's written instructions for evaluating, preparing, and treating substrate, technical data, and tested physical and performance properties of waterproofing.
- .2 Warranties: Special warranties specified in this Section.
- .3 Compatibility between components of roofing system is essential. Upon completion of Work, provide written declaration to Owner's Representative stating that materials and components, as assembled in system, meet this requirement.

1.5 QUALITY ASSURANCE

- .1 Installer Qualifications: A firm that is acceptable to waterproofing manufacturer for installation of waterproofing required for this Project.
- .2 Source Limitations: Obtain waterproofing materials, protection course, and moulded-sheet drainage panels through one source from a single manufacturer.
- .3 Mock-ups: Contractor to construct mock-up in accordance with Section 01 40 00 - Quality Requirements.

- .1 Before beginning installation, install waterproofing to 10 sq. m of deck and wall to demonstrate surface preparation, crack and joint treatment, corner treatment, and execution quality.
- .2 If Owner's Representative determines mock-ups do not comply with requirements, reapply waterproofing and reinstall overlying construction until mockups are approved.
- .3 Accepted mock up may form part of completed work.
- .4 When accepted, mock-up will demonstrate minimum standard of quality required for this work.

1.6 DELIVERY, STORAGE, AND HANDLING

- .1 Refer to Section 01 60 00 - Product Requirements for storage and handling requirements.
- .2 Deliver materials to Project site in original containers with seals unbroken and labelled with manufacturer's name, product brand name, and type, date of manufacture, and directions for storage.
- .3 Store materials off-ground in weatherproof storage.
- .4 Store materials in upright position. Store membrane rolls with selvage edge up, store as per manufacturer's requirements to meet warranty.
- .5 Remove only in quantities required for same day use.
- .6 Store adhesives and sealants as per manufacturer's recommendations
- .7 Protect stored materials from direct sunlight.
- .8 Store liquid materials in their original undamaged containers in a clean, dry, protected location and within the temperature range required by roofing system manufacturer. Protect stored liquid material from direct sunlight.
 - .1 Discard and legally dispose of liquid material that cannot be applied within its stated shelf life.

1.7 PROJECT CONDITIONS

- .1 Environmental Limitations: Apply waterproofing within the range of ambient and substrate temperatures recommended by waterproofing manufacturer. Do not apply waterproofing to a damp or wet substrate.
 - .1 Do not apply waterproofing in snow, rain, fog, or mist.
- .2 Maintain adequate ventilation during preparation and application of waterproofing materials.
- .3 Install roofing on dry deck, free of snow and ice, use only dry materials and apply only during weather that will not introduce moisture into waterproofing system.

1.8 WARRANTY

- .1 Provide a written guarantee signed and issued in the name of The Owner by the Waterproofing System Manufacturer stating that waterproofing system is free from manufacturing defects and that the system will stay in place and remain leak proof for a period of ten (10) years from date of Substantial Certificate of Completion, subject to the standard limitations and conditions of the manufacturer. Standard Warranty includes membranes, membrane flashings, roof insulation, fasteners/adhesives, cover boards, substrate board and all associated flashings.
- .2 Provide a written guarantee, signed and issued in the name of the Owner by the Contractor, stating that the roofing application has been performed in compliance with the plans and specifications, and for two (2) years from the date

of Substantial Certificate of Completion, the Contractor shall repair, at no expense to the Owner, any defects which result of a failure to comply with the plans and specifications.

- .3 Special Installer's Warranty: Specified form, on warranty form at end of this Section, signed by Installer, covering Work of this Section, for warranty period of two years.
 - .1 Warranty includes removing and reinstalling earthwork, drainage panels, insulation, and all associated Work to reinstate waterproofing membranes.
- .4 Warranty to be non-prorated.

PART 2 - PRODUCTS

2.1 MODIFIED BITUMINOUS SHEET WATERPROOFING

- .1 Modified Bituminous Sheet: two (2) layers, Minimum total thickness 6.0mm, to CGSB-37.56-M, Styrene-Butadiene-Styrene (SBS) elastomeric polymer, prefabricated sheet, non woven, polyester reinforcement, weighing 180 g/m².
 - .1 Type 2, fully adhered
 - .2 Class P-plain surfaced
 - .3 Grade 2
 - .4 Top and bottom surfaces:
 - .1 Polyethylene/polyethylene
 - .5 Base sheet membrane properties:
 - .1 Strain energy (longitudinal/transversal): 9.0/7.0 kN/m
 - .2 Breaking strength (longitudinal/transversal): 17.0/12.5 N/5 cm
 - .3 Ultimate elongation (longitudinal/transversal): 60/65 %
 - .4 Tear resistance: 60 N
 - .5 Cold bending at -30 degrees C : no cracking
 - .6 Static puncture resistance: > 400
 - .7 Dimensional Stability: -0.3 / 0.3 %
 - .6 Acceptable products:
 - .1 Sopralene Flam 180, as manufactured by Soprema.
 - .2 Torchflex TP-180-FF-Base, as manufactured by IKO.
 - .3 Approved alternate.

2.2 BASE SHEET/REINFORCMENT MEMBRANE FLASHING

- .1 To CGSB-37.56-M, Type 2, Class C, Grade 2, non-woven polyester reinforced 180g/m², self-adhesive membrane with polyethylene top face and release film under face.
 - .1 Approved product:
 - .1 Sopralene Flam Stick as manufactured by Soprema.
 - .2 Armourbond 180, as manufactured by IKO.
 - .3 Approved alternate.

2.3 SEALANTS

- .1 Mastic made of synthetic rubbers, plasticized with bitumen and solvents with aluminum pigments to provide greater resistance to U.V.
 - .1 Acceptable products:
 - .1 Sopramastic as manufactured by Soprema.
 - .2 AquaBarrier Mastic, as manufactured by IKO.
 - .3 Approved alternate.

2.4 PRIMERS

- .1 For self-adhesive membranes: as recommended by membrane manufacturer. A blend of elastomeric bitumen, volatile solvents and adhesive enhancing resins used to prime porous and non-porous substrates such as gypsum board, wood, concrete or metal to enhance the adhesion of self-adhesive membranes at temperatures above -10°C
- .2 For heat welded membranes: as recommended by membrane manufacturer. A blend of elastomeric bitumen, volatile solvents and adhesive enhancing additives used to prime concrete or metal substrates to enhance the adhesion of torch-applied membranes.

2.5 INSULATION

- .1 Contractor to provide minimum 2 layers of insulation with joints staggered minimum 150mm. Base layer of insulation to be minimum 38mm (1-1/2"). Provide top layer of custom designed tapered insulation with minimum slope of 2%. Provide crickets where required to ensure positive drainage away from existing foundation walls.
 - .1 Extruded Polystyrene Insulation (XPS):
 - .1 To CAN/UJC-S701, Type 2, square edged.
 - .2 Adhesive: as recommended by insulation Manufacturer for adhering insulation to substrate.

.2 AUXILIARY MATERIALS

- .3 General: Furnish auxiliary materials recommended by waterproofing manufacturer for intended use and compatible with waterproofing (base sheet) membranes.
- .4 Termination Bar: 25mm (1") corrosion resistant termination bar complete with upper reservoir for sealant application and pre-punched holes for fasteners. Termination bars to be installed using approved fasteners spaced minimum 300mm (12") o.c.
- .5 Liquid Flashing: One component polyurethane/bitumen resin.
 - .1 Acceptable products:
 - .1 Alsan Flashing as manufactured by Soprema.
 - .2 IKO MS Detail, as manufactured by IKO.
 - .3 Approved alternate.

2.6 MOULDED-SHEET DRAINAGE PANELS

- .1 Three dimensional polymeric core drain board 10 mm thick, with a non-woven geotextile fabric fully bonded to top dimples of board.

PART 3 - EXECUTION

3.1 EXAMINATION

- .1 Examine substrates, areas, and conditions, with Installer present, for compliance with requirements and other conditions affecting performance.
 - .1 Verify that concrete has cured and aged for minimum time period recommended by waterproofing manufacturer.
 - .2 Verify that concrete is visibly dry and free of moisture.
 - .3 Proceed with installation only after unsatisfactory conditions have been corrected.

3.2 SURFACE PREPARATION

- .1 Clean, prepare, and treat substrates according to manufacturer's written instructions. Provide clean, dust-free, and dry substrates for waterproofing application.
- .2 Mask off adjoining surfaces not receiving waterproofing to prevent spillage and torching (heat) affecting other construction.
- .3 Remove grease, oil, bitumen, form-release agents, paints, curing compounds, and other penetrating contaminants or film-forming coatings from concrete.
- .4 Remove fins, ridges, mortar, and other projections and fill honeycomb, aggregate pockets, holes, and other voids.
- .5 Prepare, fill, prime, and treat joints and cracks in substrates. Remove dust and dirt from joints and cracks according to ASTM D 4258.
- .6 Bridge and cover isolation joints, expansion joints, and discontinuous deck-to-wall and deck-to-deck joints with overlapping reinforcement sheet strips.
- .7 Install reinforcement membrane strips centered over corners and joints in concrete as detail on the Drawings.
- .8 Prepare, treat, and seal vertical and horizontal surfaces at terminations and penetrations through waterproofing and at protrusions according to ASTM D 6135 and in the Drawings.

3.3 MODIFIED BITUMINOUS SHEET WATERPROOFING APPLICATION

- .1 Prime all surfaces as per manufacturer's instructions.
- .2 Starting at low point of roof, perpendicular to slope, unroll base sheet membrane, align and reroll from both ends.
- .3 Unroll and torch base sheet membrane onto recover board taking care not to burn membrane or its reinforcement.
- .4 Lap sheets 75 mm minimum for side and 150 mm minimum for end laps. Stagger end laps a minimum of 300mm.
- .5 Install base sheet membrane flashing at all intersections and as indicated on the Drawings. Lap sheets 75 mm minimum for side and 150 mm minimum for end laps. Complete installation of base sheet membrane flashing prior to installing second layer of base sheet membrane waterproofing.
- .6 Installer to ensure all leading edges are sealed with an approved sealant and/or seams are "buttered" in accordance with manufacturer's instructions.
- .7 Install second layer of base sheet membrane using the above application.
- .8 Install upper base sheet membrane flashing at all intersections and as indicated on the Drawings. Lap sheets 75 mm minimum for side and 150 mm minimum for end laps. Supply and install termination bar using approved fasteners at 300mm o.c. minimum. Trim excess membranes and apply a continuous bead of sealant. Install liquid membrane flashing at leading edge of all protrusions as per Drawings and manufacturer's recommendations.
- .9 Application to be free of blisters, fishmouths and wrinkles.

- .10 Do membrane application in accordance with manufacturer's recommendations.
- .11 Do not enclose membrane until it has been inspected and approved by Owner's Representative.

3.4 INSULATION INSTALLATION

- .1 Comply with manufacturer's written instructions for installing insulation.
- .2 Apply adhesive to insulation board in accordance with manufacturer's recommendations.
- .3 Install insulation in accordance with shop drawings.
- .4 Install insulation after building substrate materials are dry.
- .5 Install insulation to maintain continuity of thermal protection to building elements and spaces.
- .6 Fit insulation tight around all protrusions.
- .7 Cut and trim insulation neatly to fit spaces. Butt joints tightly, offset vertical joints. Use only insulation boards free from chipped or broken edges. Use largest possible dimensions to reduce number of joints.
- .8 Offset both vertical and horizontal joints in multiple layer applications, 150mm minimum.
- .9 Do not enclose insulation until it has been inspected and approved by Owner's Representative. Cover membrane immediately after Owner's Representative's inspection to protect from damage by other trades.

3.5 MOULDED-SHEET DRAINAGE PANEL INSTALLATION

- .1 Place and secure moulded-sheet drainage panels, with geotextile facing away from wall or deck substrate, according to manufacturer's written instructions. Use adhesives that do not penetrate waterproofing. Lap edges and ends of geotextile to maintain continuity.

3.6 PROTECTION AND CLEANING

- .1 Do not permit foot or vehicular traffic on unprotected membrane.
- .2 Protect waterproofing from damage and wear during remainder of construction period.
- .3 Clean spillage and soiling from adjacent construction using cleaning agents and procedures recommended by manufacturer of affected construction.

END OF SECTION

PART 1 - GENERAL

1.1 DESCRIPTION OF WORK

- .1 Provide labour, materials, services and equipment necessary to complete the work of this section. Work includes, but is not limited to the following:
 - .1 Fabricate and install new prefinished steel counter flashings at the top of all new foundation wall terminations, as detailed on the drawings.
 - .2 Perform all other flashing related work as detailed on the drawings or specified herein.

1.2 RELATED DOCUMENTS

- .1 Drawings and general provisions of the Contract, including General and Supplementary Conditions and Division 01 Specification Sections, apply to this Section.

1.3 REFERENCES

- .1 The Aluminum Association Inc. (AA)
 - .1 Aluminum Sheet Metal Work in Building Construction.
 - .2 AA DAF45, Designation System for Aluminum Finishes.
- .2 American Society for Testing and Materials (ASTM International)
 - .1 ASTM A653/A653M, Standard Specification for Steel Sheet, Zinc-Coated (Galvanized) or Zinc-Iron Alloy-Coated (Galvannealed) by the Hot-Dip Process.
 - .2 ASTM A792/A792M, Standard Specification for Steel Sheet, 55% Aluminum-Zinc Alloy-Coated by the Hot-Dip Process.
 - .3 ASTM D523, Standard Test Method for Specular Gloss.
 - .4 ASTM D5796, Standard Test Method for Measurement of Dry Film Thickness of Thin Film Coil-Coated Systems by Destructive Means Using a Boring Device
 - .5 ASTM D822, Standard Practice for Filtered Open-Flame Carbon-Arc Exposures of Paint and Related Coatings.
- .3 Canadian General Standards Board (CGSB)
 - .1 CAN/CGSB-93.1-M85, Sheet, Aluminium Alloy, Prefinished, Residential.
 - .2 CAN/CGSB-93.4-92, Galvanized Steel and Aluminum-Zinc Alloy Coated Steel Siding Soffits and Fascia, Prefinished, Residential.
 - .3 CAN/CGSB 1.181-99, Ready-Mixed Organic Zinc-Rich Coating.
- .4 American Architectural Manufacturers Association (AAMA)
 - .1 AAMA 2605-05, Voluntary Specification, Performance Requirements and Test Procedures for Superior Performing Organic Coatings on Aluminum Extrusions and Panels.
 - .2 AAMA 620-02, Voluntary Specification for High Performance Organic Coatings on Coil Coated Architectural Aluminum Substrates.
- .5 American National Standards Institute (ANSI)
 - .1 ANSI B18.6.4-1981 (R1991), Screws, Tapping and Metallic Drive, Inch Series, Thread Forming and Cutting.
 - .2 Copper in Architecture Handbook (1998), Copper Development Association (CDA) and Canadian Copper & Brass Development Association (CCBDA).
- .6 Canadian Roofing Contractors Association (CRCA)

- .1 Roofing Specifications Manual.
- .7 Canadian Standards Association (CSA International)
 - .1 CSA B111, Wire Nails, Spikes and Staples.
- 1.4 PERFORMANCE REQUIREMENTS
 - .1 General: Sheet metal flashing and trim assemblies as indicated shall withstand wind loads, structural movement, thermally induced movement, and exposure to weather without failure due to defective manufacture, fabrication, installation, or other defects in construction. Completed sheet metal flashing and trim shall not rattle, leak, or loosen, and shall remain watertight.
 - .2 Thermal Movements: Provide sheet metal flashing and trim that allows for thermal movements from ambient and surface temperature changes.
 - .1 Temperature Change (Range): 67 deg C, ambient; 100 deg C, material surfaces.
- 1.5 SUBMITTALS
 - .1 Submit manufacturer's printed product literature for sheet metal flashing systems materials, specifications and datasheet and include product characteristics, performance criteria, physical size, finish and limitations.
 - .2 Submit samples for all sheet metal flashing materials proposed for use on this project, as follows:
 - .1 Submit duplicate, 150 x 150 mm sample(s) of each type of sheet metal material specified (in a range of manufacturer's standard colours to demonstrate colour match of new flashing material to new adjacent curtain wall system, for review and final selection by the owner. Colour match shall be demonstrated and approved by owner prior to undertaking work.
 - .2 Allow for one re-submission of each colour should adjustment to proposed colour be required by the owner.
 - .3 Sample(s) to include reference to manufacturer's colour code, colour name and base metal flashing thickness.
- 1.6 QUALITY ASSURANCE
 - .1 Fabricator Qualifications: Shop that employs skilled workers who custom fabricate sheet metal flashing and trim similar to that required for this Project and whose products have a record of successful in-service performance.
 - .2 Sheet Metal Flashing and Trim Standard: Comply with SMACNA's *Architectural Sheet Metal Manual* unless more stringent requirements are specified or shown on Drawings.
 - .3 Mock-ups: Build mock-ups to verify selections made under sample submittals and to demonstrate aesthetic effects and set quality standards for fabrication and installation.
 - .1 Construct mock-up of each type of sheet metal flashing and trim, including supporting construction cleats, seams, attachments, underlying membrane flashing, and accessories. Mock-up may be part of finished work
 - .2 Allow 48 hours for inspection of mock-up by Owner's Representative.
 - .3 Approval of mock-ups does not constitute approval of deviations from the Contract Documents contained in mock-ups unless Owner's Representative specifically approves such deviations in writing.
 - .4 Mock-up will be used to judge workmanship, substrate preparation, and material application
 - .5 Approved mock-ups may become part of the completed Work if undisturbed at time of Substantial Completion.
 - .6 When accepted, mock-up will demonstrate minimum standard of quality required for this work.
- 1.7 DELIVERY, STORAGE, AND HANDLING

- .1 Do not store sheet metal flashing and trim materials in contact with other materials that might cause staining, denting, or other surface damage. Store sheet metal flashing and trim materials away from uncured concrete and masonry.
- .2 Protect strippable protective covering on sheet metal flashing and trim from exposure to sunlight and high humidity, except to the extent necessary for the period of sheet metal flashing and trim installation.

PART 2 - PRODUCTS

2.1 PREFINISHED STEEL SHEET

- .1 General: Protect mechanical and other finishes on exposed surfaces from damage by applying a strippable, temporary protective film before shipping.
- .2 Prefinished sheet with a factory applied fluoropolymer 2-coat coating system, comprised of a corrosion inhibiting primer and a colour coat utilizing the polyvinylidene fluoride (PVDF) resins, supplemented as follows:
 - .1 Base sheet steel material: Apply polyvinylidene fluoride (PVDF) coating overtop of steel sheet containing the following coatings (note: base metal thickness as specified below):
 - .1 55% Aluminum-zinc (Galvalume) alloy coated sheet steel conforming to the requirements of ASTM A792/A792M, commercial quality, with a minimum coating weight of AZM150 150g/m², minimum triple spot
 - .2 Grade: 33
 - .2 Class F1S
 - .3 Colour as selected by Owner's Representative from manufacturer's standard range to match existing/adjacent metal flashing.
 - .4 Specular gloss: 30 units +/- 5 in accordance with ASTM D523.
 - .5 Film thickness: Dry film thickness of 25um +/- 5um (1.0mils +/- 0.1mils) in accordance with ASTM D5796
 - .6 Resistance to accelerated weathering for caulk rating of 8, colour fade 5 units or less and erosion rate less than 20 % to ASTM D822 as follows:
 - .1 Outdoor exposure period 2500 hours.
 - .2 Humidity resistance exposure period 5000 hours.
- .3 Base metal flashing thickness for use on this project is as follows:
 - .1 Metal parapet flashings: 0.61mm (0.024") thick
 - .2 Counterflashings and throughwall flashings: 0.46mm (0.018") thick
- .4 Acceptable coating system:
 - .1 10,000 Series Finish, as manufactured by ArcelorMittal Dofasco Inc.

2.2 GALVANIZED METAL FLASHING

- .1 Zinc coated (hot-dipped galvanized) steel sheet (for use as transition flashing to support new S/A membrane installation as identified on the drawings): Continuous zinc coated steel sheet, commercial quality, conforming to ASTM A 653/A653M, supplemented as follows:
 - .1 Minimum zinc coating weight: Z275-275 g/m² thick, minimum triple spot.
 - .2 Base metal thickness: 0.55mm (0.022") thick, profile as shown on the drawings

2.3 UNDERLAYMENT MATERIALS

- .1 Self-Adhering, High-Temperature Sheet: Minimum 0.76 to 1.0 mm thick, consisting of slip-resisting polyethylene-film top surface laminated to layer of butyl or SBS-modified asphalt adhesive, with release-paper backing; cold applied. Provide primer when recommended by underlayment manufacturer.
 - .1 Thermal Stability: ASTM D 1970; stable after testing at 116 deg C.
 - .2 Low-Temperature Flexibility: ASTM D 1970; passes after testing at minus 29 deg C.

- .2 Slip Sheet: Building paper, 0.16-kg/sq. m minimum, rosin sized.

2.4 MISCELLANEOUS MATERIALS

- .1 General: Provide materials and types of fasteners, protective coatings, separators, sealants, and other miscellaneous items as required for complete sheet metal flashing and trim installation and recommended by manufacturer of primary sheet metal unless otherwise indicated.
- .2 Isolation coating: alkali resistant bituminous paint.
- .3 Plastic cement: to CAN/CGSB 37.5.
- .4 Sealants: Refer to Section 07 92 00 – Joint Sealants.
- .5 Cleats: of same material, and temper as sheet metal, minimum 50 mm wide or as indicated otherwise on the drawings. Thickness same as sheet metal being secured.
- .6 Fasteners (all new flashing components): to CAN/CSA B111 and as described below:
 - .1 Exposed Fasteners: ACQ compatible, self-tapping sheet metal screws, complete with neoprene washers. Colour to match metal flashing being secured and of sufficient length to secure metal flashing to substrate (provide 1-1/2" minimum embedment into substrate).
 - .2 Hidden fasteners: galvanized, ring threaded nails of length and thickness suitable for metal flashing application.
 - .3 Fasteners used for ACQ treated wood shall be manufactured from steel either galvanized in accordance with ASTM A653/A653M, G185 designation (coating thickness of 1.85oz/ft², both sides), or be galvanized after manufacture in accordance with ASTM A123. Alternatively, the contractor may be permitted to use self-tapping stainless steel sheet metal screws (type 304 or 316) for use in ACQ treated lumber.
 - .4 Fasteners (for attachment of galvanized flashing into concrete or concrete block walls): Self tapping concrete screws, coated with a corrosion resistant finish compatible with galvanized sheet metal material.
Acceptable product/coating:
 - .1 5mm (3/16") diameter with Phillips flat head and blue stalgard coating, as manufactured by Tapcon.
 - .2 5mm (3/16") diameter, stainless steel self-tapping concrete screws, as manufactured by Tapcon.
 - .3 Approved alternate.
- .7 Washers: of same material as sheet metal, 1 mm thick with rubber packings.
- .8 Touch-up paint: as recommended by prefinished material manufacturer.
- .9 Sealant Tape: Pressure-sensitive, 100 percent solids, gray polyisobutylene compound sealant tape with release-paper backing. Provide permanently elastic, nonsag, nontoxic, nonstaining tape 13 mm wide and 3 mm thick.
- .10 Elastomeric Sealant: ASTM C 920, elastomeric silicone polymer sealant; low modulus; of type, grade, class, and use classifications required to seal joints in sheet metal flashing and trim and remain watertight.

.11 Butyl Sealant: ASTM C 1311, single-component, solvent-release butyl rubber sealant; polyisobutylene plasticized; heavy bodied for hooked-type expansion joints with limited movement.

.12 Bituminous Coating: Cold-applied asphalt emulsion complying with ASTM D 1187.

2.5 FABRICATION, GENERAL

.1 General: Custom fabricate sheet metal flashing and trim to comply with recommendations in SMACNA's *Architectural Sheet Metal Manual* that apply to design, dimensions, geometry, metal thickness, and other characteristics of item indicated. Fabricate items at the shop to greatest extent possible.

.1 Fabricate sheet metal flashing and trim in thickness or weight needed to comply with performance requirements, but not less than that specified for each application and metal.

.2 Obtain field measurements for accurate fit before shop fabrication.

.3 Form sheet metal flashing and trim without excessive oil canning, buckling, and tool marks and true to line and levels indicated, with exposed edges folded back to form hems.

.4 Conceal fasteners and expansion provisions where possible.

.5 Form pieces in 2400 mm maximum lengths. Make allowance for expansion at joints.

.6 Hem exposed edges on underside 12 mm. Mitre and seal corners with sealant.

.2 Fabricate non-moving seams in metal flashing, as follows:

.1 Fabricate all non-moving seams with either a "flat lock seam", or "flat lock cleated seams" or "single common lock" or "hook seams" as defined in the Copper Development Association handbook (see typical flashing details included in Figures 1 & 3, below).

.2 Fabricate all joints in exposed flashings with standard "S" pocket seams (applicable only to flashings where the above noted locking seams cannot be performed), see typical flashing details included in Figure 1, below.

.3 Fabricate expansion joints in metal flashing, as follows:

.1 Fabricate all dynamically moving expansion seams using either a "slip expansion seam" or "loose lock with sealant", as defined in the Copper Development Association handbook (see typical flashing details included in Figure 2, below).

.4 Separation of dissimilar metals/materials to prevent galvanic corrosion:

.1 Apply isolation coating to all metal surfaces to be embedded in concrete or mortar.

.2 Provide separation of metal from non-compatible metal or corrosive substrates by coating all concealed surfaces at locations of contact, with bituminous coating or other permanent separation (such as a S/A membrane), as approved by the Owner's Representative.

.5 No exposed or visible flashing work shall be unfinished (i.e. visible undersides, joints, etc...).

.6 Fabricate cleats and attachment devices from same material as accessory being anchored or from compatible, noncorrosive metal.

.7 Fabricate cleats and attachment devices of sizes as recommended by SMACNA's *Architectural Sheet Metal Manual* and by FM Global Loss Prevention Data Sheet 1-49 for application, but not less than thickness of metal being secured.

.8 Do not use graphite pencils to mark metal surfaces.

PART 3 - EXECUTION

3.1 MANUFACTURER'S INSTRUCTIONS

- .1 Compliance: comply with manufacturer's written recommendations, including product technical bulletins, handling, Storage and installation instructions, and datasheets.

3.2 EXAMINATION

- .1 Examine substrates, areas, and conditions, with Installer present, to verify actual locations, dimensions and other conditions affecting performance of the Work.
 - .1 Verify compliance with requirements for installation tolerances of substrates.
 - .2 Verify that substrate is sound, dry, smooth, clean, sloped for drainage, and securely anchored.
- .2 For the record, prepare written report, endorsed by Installer, listing conditions detrimental to performance of the Work.
- .3 Proceed with installation only after unsatisfactory conditions have been corrected.

3.3 INSTALLATION, GENERAL

- .1 Coordinate all flashing work with other trades.
- .2 Install sheet metal work in accordance with CRCA FL series details and as detailed on the drawings.
- .3 Form and lock joints of all metal flashing as described above and in accordance with the typical details included in the Copper Development Association Handbook (details attached) or as shown on the drawings.
- .4 Use concealed fastenings except where approved before installation by the Owner's Representative.
- .5 Provide underlay under sheet metal. Secure in place and lap joints 100 mm.
- .6 Counterflash bituminous flashings at intersections of roof with vertical surfaces and curbs as detailed on the drawings.
- .7 Install all metal flashing to provide a minimum of 50mm (2") overlapping joints.
- .8 All new metal flashing must be continuously supported. Any unsupported metal flashing will not be accepted.
- .9 Shingle and sequence all metal flashing installation to shed water away from building.
- .10 Lock end joints and caulk with sealant.
- .11 Where indicated, insert metal flashing into 25mm reglets or under cap flashing to form weather tight junction.
- .12 Install sheet metal flashing and trim true to line and levels indicated. Provide uniform, neat seams with minimum exposure of solder, welds, and sealant.
- .13 Install exposed sheet metal flashing and trim without excessive oil canning, buckling, and tool marks.

- .14 Do not use graphite pencils to mark metal surfaces.
- .15 Metal Protection: Where dissimilar metals will contact each other or corrosive substrates, protect against galvanic action by painting contact surfaces with bituminous coating or by other permanent separation as recommended by SMACNA.
 - .1 Coat back side of uncoated aluminum and stainless-steel sheet metal flashing and trim with bituminous coating where flashing and trim will contact wood, ferrous metal, or cementitious construction.
 - .2 Underlayment: Where installing metal flashing directly on cementitious or wood substrates, install a course of felt underlayment and cover with a slip sheet.

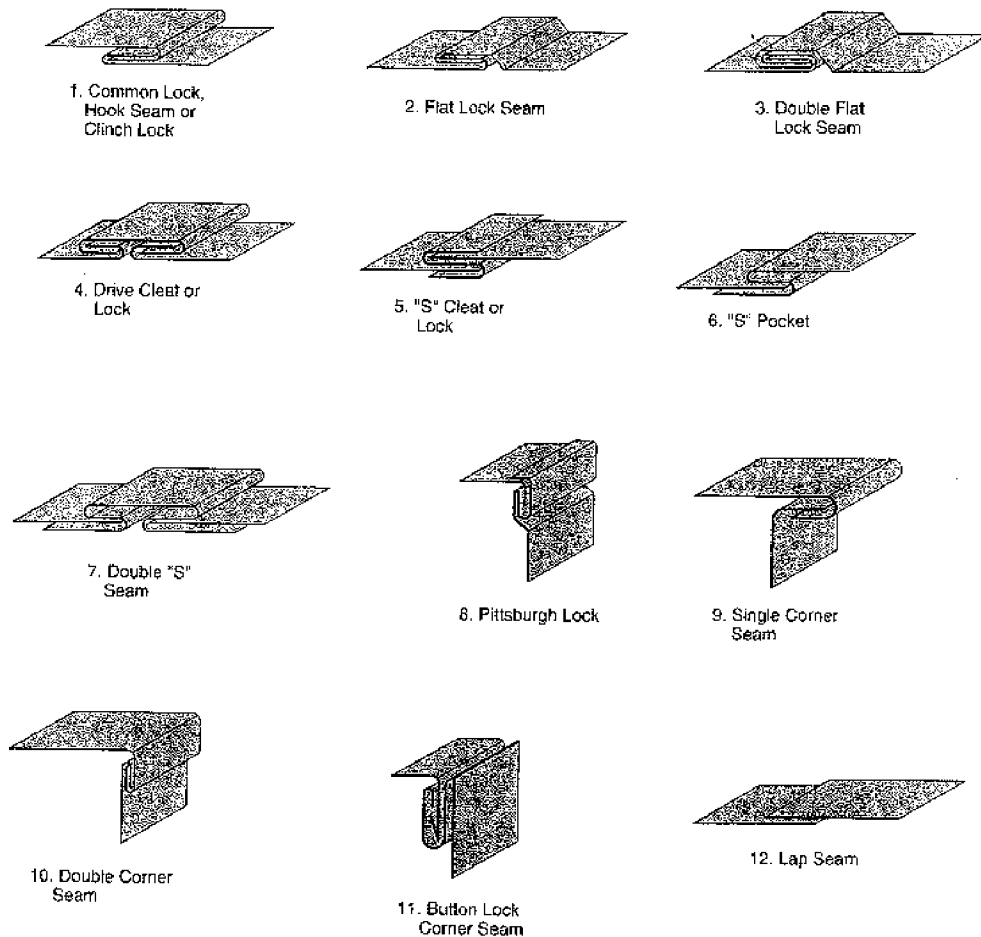
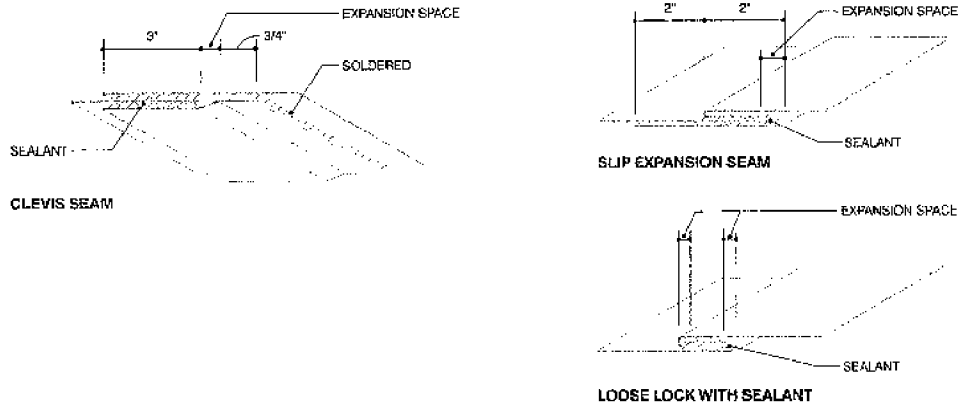

Figure 1 – Typical Flashing Joints-Seams



A. Expansion Seams

FILE: BAS-102

Figure 2 – Typical Expansion Seams

Note: Above details were taken from the Copper Development Association Handbook (CDA)

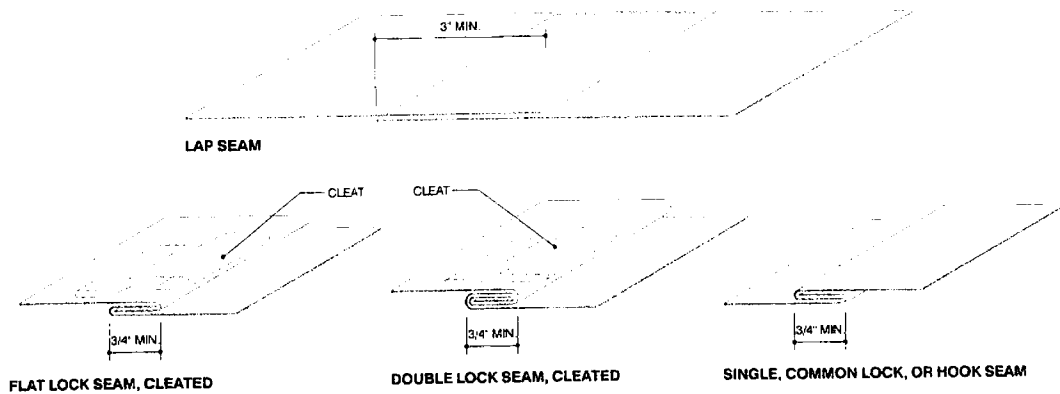

B. Loose Seams

FILE: BAS-101

Figure 3 – Typical Loose Seams

Note: Above details were taken from the Copper Development Association Handbook (CDA)

3.4 CLEANING AND PROTECTION

- .1 Clean off excess sealants.
- .2 Remove temporary protective coverings and strippable films as sheet metal flashing and trim are installed unless otherwise indicated in manufacturer's written installation instructions. On completion of installation, remove unused materials and clean finished surfaces. Maintain in a clean condition during construction.
- .3 Replace sheet metal flashing and trim that have been damaged or that have deteriorated beyond successful repair by finish touchup or similar minor repair procedures.

END OF SECTION

PART 1 - GENERAL

1.1 DESCRIPTION OF WORK

- .1 Provide labour, materials, services and equipment necessary to complete the work of this section. Work includes, but is not limited to the following:
 - .1 Installation of new exterior sealant all joints between metal flashing and cladding elements and all other joints as indicated on the drawings.
 - .2 Installation of new sealant at all other locations as indicated on the drawings or specified herein.

1.2 REFERENCES

- .1 American Society for Testing and Materials International, (ASTM)
 - .1 ASTM C 834-10, Standard Specification for Latex Sealants
 - .2 ASTM C 919-12, Standard Practice for Use of Sealants in Acoustical Applications.
 - .3 ASTM C 920-11, Standard Specification for Elastomeric Joint Sealants
 - .4 ASTM C 1193-12, Standard Guide for Use of Joint Sealants
 - .5 ASTM C 1521-09e1, Standard Practice for Evaluating Adhesion of Installed Weatherproofing Sealant Joints.
- .2 Department of Justice Canada (Jus)
 - .1 Canadian Environmental Protection Act (CEPA).
- .3 Health Canada/Workplace Hazardous Materials Information System (WHMIS)
 - .1 Material Safety Data Sheets (MSDS)
- .4 Transport Canada (TC)
 - .1 Transportation of Dangerous Goods Act (TDGA).

1.3 SUBMITTALS

- .1 Product Data: For each joint-sealant product indicated.
- .2 Samples for Initial Selection: Manufacturer's colour charts consisting of strips of cured sealants showing the full range of colours available for each product exposed to view.
- .3 Joint-Sealant Schedule: Include the following information for each product used:
 - .1 Joint-sealant application, joint location, and designation.
 - .2 Joint-sealant manufacturer, product name, installation instructions, surface preparation and product limitations.
 - .3 Joint-sealant formulation.
 - .4 Joint-sealant primer.
 - .5 Joint-sealant colour.
- .4 Product Test Reports: Based on evaluation of comprehensive tests performed by a qualified testing agency, indicating that sealants comply with requirements.
- .5 Warranties: Sample of special warranties.

1.4 QUALITY ASSURANCE

- .1 Source Limitations: Obtain each kind of joint sealant from single source from single manufacturer.
- .2 Construct mock-up to show location, size, shape and depth of joints complete with back-up material, primer, caulking and sealant. Mock-up may be part of finished work. Mock-ups required includes the following:
 - .1 Perimeter of one complete aluminum curtain wall system (exterior and interior sealant applications).
 - .2 At one exterior control joint within the new composite panel cladding with existing limestone panels.
- .3 Allow 48 hours for inspection of mock-up by Owner's Representative before proceeding with sealant work.
- .4 Mock-up will be used to judge workmanship, substrate preparation, operation of equipment and material application.
- .5 When accepted, mock-up will demonstrate minimum standard of quality required for this Work..

1.5 DELIVERY, STORAGE AND HANDLING

- .1 Deliver, handle, store and protect materials in accordance with Section 01 60 00 - Product Requirements.
- .2 Deliver and store materials in original wrappings and containers with manufacturer's seals and labels, intact. Protect from freezing, moisture, water and contact with ground or floor

1.6 PROJECT CONDITIONS

- .1 Do not proceed with installation of joint sealants under the following conditions:
 - .1 When ambient and substrate temperature conditions are outside limits permitted by joint-sealant manufacturer or are below 4.4°C.
 - .2 When joint substrates are wet.
- .2 Joint-Width Conditions:
 - .1 Do not proceed with installation of joint sealants where joint widths are less than those allowed by joint sealant manufacturer for applications indicated.
- .3 Joint-Substrate Conditions:
 - .1 Do not proceed with installation of joint sealants until contaminants capable of interfering with adhesion are removed from joint substrates.

1.7 WARRANTY

- .1 For the work of this Section, the contractor shall warrant all sealant installation work for a period of not less than 60 months (5 years) from the date of substantial completion.
- .2 The manufacturer shall provide a material warranty for a period not less than 60 months (5 years) from the date of substantial completion.
- .3 The Contractor shall provide a written installation warranty stating that the sealant will be free of defects related to workmanship, installation and material deficiency for the period noted above. The following shall be specifically covered under the warranty: water penetration, separation, scaling, debonding, crazing, cracking, bubbling, shrinkage, disintegration, pinholing, sagging, loss of adhesion, loss of cohesion, and staining of the adjoining or adjacent materials or surfaces.

- .4 Correct all deficiencies or sealant failures immediately. Any repair(s) required under the warranty shall be carried out in accordance with the requirements of this specification section and recommendations of the manufacturer and Owner's Representative. The contractor shall include as part of their material and installation warranty all costs associated with providing access to facilitate any replacement under the project warranties.

PART 2 - PRODUCTS

2.1 MATERIALS, GENERAL

- .1 **Compatibility:** Provide joint sealants, backings, and other related materials that are compatible with one another and with joint substrates under conditions of service and application, as demonstrated by joint-sealant manufacturer, based on testing and field experience.
- .2 Sealant and caulking compounds must be accompanied by detailed instructions for proper application so as to minimize health concerns and maximize performance, and information describing proper disposal methods.
- .3 Where sealants are qualified with primers use only these primers.
- .4 **VOC Content of Interior Sealants:** Provide sealants and sealant primers for use inside the weatherproofing system that comply with the following limits for VOC content when:
 - .1 Architectural Sealants: 250 g/L.
 - .2 Sealant Primers for Nonporous Substrates: 250 g/L.
 - .3 Sealant Primers for Porous Substrates: 775 g/L.

2.2 SEALANT MATERIAL DESIGNATIONS

- .1 **Type 1 Sealant (for use as exterior sealant):** Single component, neutral-curing, low modulus, non-staining construction grade silicone sealant with +/- 50% movement capability, to ASTM C920:
 - .1 **Acceptable Material:**
 - .1 Spectrem 2, as manufactured by Tremco Canada.
 - .2 Dow Corning 795, Silicone sealant.
 - .3 Approved alternate.
 - .2 **Sealant Colour:**
 - .1 As selected and approved by the owner from the manufacturer's standard colour range.
- .2 **Type 2 sealant (for use at joints in the glazing tape or exterior dry glazing gaskets of fixed window systems glazed on-site):** High performance, Medium Modulus, one-part, neutral cure, silicone sealant to ASTM C920.
 - .1 **Acceptable Materials:**
 - .1 Dow Corning 795
 - .2 Spectrem 2, as manufactured by Tremco Canada
 - .3 An approved alternate
 - .2 **Colour:** Black
- .3 **Type 3 sealant (heel bead for rainscreen window systems):** High performance, Medium Modulus, one-part, neutral cure, silicone sealant to ASTM C920.
 - .1 **Acceptable Materials:**
 - .1 Dow Corning 795
 - .2 Spectrem 2, as manufactured by Tremco Canada
 - .3 An approved alternate
 - .2 **Colour:** Black

- .4 Type 4 sealant (for use as interior sealant between all trim/window systems): General purpose, paintable, acrylic latex sealant complying with ASTM C920. Joint movement capacity +/- 10%.
 - .1 Acceptable Material:
 - .1 Tremco Tremflex 834, as manufactured by Tremco Canada,
 - .2 An approved alternate.
 - .2 Colour: As selected and approved by the owner from the manufacturer's standard colour range.

- .5 Type 5 sealant (for application at lap joints and perimeter of new polyethylene sheets): Acoustical Sealant to ASTM C919, single component, non-curing.
 - .1 Acceptable material:
 - .1 Acoustical sealant, as manufactured by Tremco Canada
 - .2 An approved alternate.

2.3 SEALANT ACCESSORIES

- .1 Preformed Compressible and Non-Compressible back-up materials.
 - .1 High Density Foam:
 - .1 Extruded closed cell extruded polyethylene, closed cell, Shore A hardness 20, tensile strength 140 to 200 kPa, extruded polyolefin foam, 32 kg/m³ density, or neoprene foam backer, size as recommended by manufacturer.
 - .2 Bond Breaker Tape:
 - .1 Polyethylene bond breaker tape which will not bond to sealant.

2.4 JOINT CLEANER

- .1 Non-corrosive and non-staining type, compatible with joint forming materials and sealant recommended by sealant manufacturer.

PART 3 - EXECUTION

3.1 EXAMINATION

- .1 Examine joints indicated to receive joint sealants, with Installer present, for compliance with requirements for joint configuration, installation tolerances, and other conditions affecting joint-sealant performance.
- .2 Proceed with installation only after unsatisfactory conditions have been corrected.

3.2 PROTECTION

- .1 Protect installed Work of other trades from staining or contamination.

3.3 SURFACE PREPARATION

- .1 Examine joint sizes and conditions to establish correct depth to width relationship for installation of backup materials and sealants.
- .2 Clean bonding joint surfaces of harmful matter substances including dust, rust, oil grease, and other matter which may impair work. Use 'two cloth' method for solvent cleaning.
- .3 Do not apply sealants to joint surfaces treated with sealer, curing compound, water repellent, or other coatings unless tests have been performed to ensure compatibility of materials. Remove coatings as required.

.4 Ensure joint surfaces are dry and frost free.

.5 Prepare surfaces in accordance with manufacturer's directions.

3.4 PRIMING

.1 Prime joint substrates where recommended by joint-sealant manufacturer or as indicated by preconstruction joint-sealant-substrate tests or prior experience. Apply primer to comply with joint-sealant manufacturer's written instructions. Confine primers to areas of joint-sealant bond; do not allow spillage or migration onto adjoining surfaces.

.2 Use masking tape where required to prevent contact of sealant or primer with adjoining surfaces that otherwise would be permanently stained or damaged by such contact or by cleaning methods required to remove sealant smears. Remove tape immediately after tooling without disturbing joint seal.

3.5 BACKUP MATERIAL

.1 Apply bond breaker tape where required to manufacturer's instructions.

.2 Install joint filler to achieve correct joint depth and shape, with approximately 30% compression.

3.6 INSTALLATION OF JOINT SEALANTS

.1 Sealant:

.1 Apply sealant in accordance with manufacturer's written instructions.

.2 Mask edges of joint where irregular surface or sensitive joint border exists to provide neat joint.

.3 Apply sealant in continuous beads.

.4 Apply sealant using gun with proper size nozzle.

.5 Use sufficient pressure to fill voids and joints solid.

.6 Form surface of sealant with full bead, smooth, free from ridges, wrinkles, sags, air pockets, embedded impurities.

.7 Tool exposed surfaces before skinning begins to give slightly concave shape.

.8 Remove excess compound promptly as work progresses and upon completion

.2 Curing:

.1 Cure sealants in accordance with sealant manufacturer's instructions.

.2 Do not cover up sealants until proper curing has taken place.

.3 Cleanup:

.1 Clean adjacent surfaces immediately and leave Work neat and clean.

.2 Remove excess and droppings, using recommended cleaners as work progresses.

.3 Remove masking tape after initial set of sealant.

3.7 CLEANING

.1 Clean adjacent surfaces immediately and leave Work neat and clean.

.2 Remove excess and droppings, using recommended cleaners as work progresses.

.3 Remove masking tape after initial set of sealant.

- .4 Upon completion remove surplus materials, rubbish, tools and equipment.

END OF SECTION

PART 1 GENERAL

1.1 REFERENCES

- .1 Canadian Standards Association (CSA)
 - .1 CAN/CSA C22.2 No. 18, Outlet Boxes, Conduit Boxes, and Fittings and Associated Hardware, a National Standard of Canada.
 - .2 CSA C22.2 No. 45, Rigid Metal Conduit.
 - .3 CSA C22.2 No. 56, Flexible Metal Conduit and Liquid-Tight Flexible Metal Conduit.
 - .4 CSA C22.2 No. 83, Electrical Metallic Tubing.
 - .5 CSA C22.2 No. 211.2, Rigid PVC (Unplasticized) Conduit.
 - .6 CAN/CSA C22.2 No. 227.3, Nonmetallic Mechanical Protection Tubing (NMPT), a National Standard of Canada.

1.2 SUBMITTALS

- .1 Product data: submit manufacturer's printed product literature, specifications and datasheets.
 - .1 Submit cable manufacturing data.
- .2 Quality assurance submittals:
 - .1 Test reports: submit certified test reports.
 - .2 Certificates: submit certificates signed by manufacturer certifying that materials comply with specified performance characteristics and physical properties.
 - .3 Instructions: submit manufacturer's installation instructions.

PART 2 PRODUCTS

2.1 CONDUITS

- .1 Rigid metal conduit: to CSA C22.2 No. 45, hot dipped galvanized steel threaded.
- .2 Epoxy coated conduit: to CSA C22.2 No. 45, with zinc coating and corrosion resistant epoxy finish inside and outside.
- .3 Electrical metallic tubing (EMT): to CSA C22.2 No. 83, with couplings.
- .4 Rigid PVC conduit: to CSA C22.2 No. 211.2.
- .5 Flexible metal conduit: to CSA C22.2 No. 56, aluminum liquid-tight flexible metal.
- .6 FRE conduit: to CSA C22.2.
- .7 Flexible PVC conduit: to CAN/CSA-C22.2 No. 227.3,

2.2 CONDUIT FASTENINGS

- .1 One hole steel straps to secure surface conduits 50 mm and smaller. Two hole steel straps for conduits larger than 50 mm.
- .2 Beam clamps to secure conduits to exposed steel work.
- .3 Channel type supports for two or more conduits at 1.5 m oc.
- .4 Threaded rods, 6 mm dia., to support suspended channels.

2.3 CONDUIT FITTINGS

- .1 Fittings: manufactured for use with conduit specified. Coating: same as conduit.
- .2 Factory "ells" where 90°, 45° or 22.5° bends are required for 25 mm and larger conduits.
- .3 Ensure conduit bends other than factory "ells" are made with an approved bender. Making offsets and other bends by cutting and rejoining 90 degree bends are not permitted.
- .4 Connectors and couplings for EMT. Steel set-screw type, size as required.

2.4 EXPANSION FITTINGS FOR RIGID CONDUIT

- .1 Weatherproof expansion fittings with internal bonding assembly suitable for 100 mm linear expansion.
- .2 Watertight expansion fittings with integral bonding jumper suitable for linear expansion and 19 mm deflection in all directions.
- .3 Weatherproof expansion fittings for linear expansion at entry to panel.

2.5 FISH CORD

- .1 Polypropylene.

PART 3 EXECUTION

3.1 MANUFACTURER'S INSTRUCTIONS

- .1 Compliance: comply with manufacturer's written recommendations or specifications, including product technical bulletins, handling, storage and installation instructions, and datasheets.

3.2 INSTALLATION

- .1 Install all conduit, conduit fittings and accessories in accordance with the latest edition of the Canadian Electrical Code in a manner that does not alter, change or violate any part of the installed system components or the CSA/UL certification of these components.

- .2 Install conduits to conserve headroom in exposed locations and cause minimum interference in spaces through which they pass.
- .3 Conceal conduits except in mechanical and electrical service rooms and in unfinished areas.
- .4 Surface mount conduits except in finished areas or as indicated.
- .5 Use rigid hot dipped galvanized steel threaded conduit for exposed work below 2.4 m above finished floor.
- .6 Use epoxy coated conduit underground in corrosive areas and where exposed to exterior elements. (ie: pole mounted service entrance conduits)
- .7 Use electrical metallic tubing (EMT) except in cast concrete and above 2.4 m not subject to mechanical injury, as well as concealed work in masonry construction.
- .8 Use rigid PVC conduit underground and buried in or under concrete slab on grade.
- .9 Use FRE conduit for encasement in concrete duct bank for service entrance feeders.
- .10 Use flexible metal conduit for connection to motors in dry areas connection to recessed incandescent fixtures without a prewired outlet box connection to surface or recessed fluorescent fixtures work in movable metal partitions.
- .11 Use liquid tight flexible metal conduit for connection to motors or vibrating equipment in damp, wet or corrosive locations.
- .12 Use AC-90 for vertical power supply drops to light fixtures.
- .13 Use explosion proof flexible connection for connection to explosion proof motors.
- .14 Install conduit sealing fittings in hazardous areas. Fill with compound.
- .15 Minimum conduit size for lighting and power circuits: 19 mm. 12 mm conduit is acceptable for switch leg drops only where one two-wire circuit and ground is required.
- .16 Install EMT conduit from computer room branch circuit panel to outlet boxes located in sub floor.
- .17 Install EMT conduit from computer room branch circuit panel to junction box in sub-floor immediately below panel. Run flexible conduit from junction box to outlet boxes for each computer in sub-floor.
- .18 Bend conduit cold. Replace conduit if kinked or flattened more than 1/10th of its original diameter.
- .19 Mechanically bend steel conduit over 19 mm dia.
- .20 Field threads on rigid conduit must be of sufficient length to draw conduits up tight.
- .21 Install fish cord in empty conduits.

- .22 Run 2 - 25 mm spare conduits up to ceiling space and 2 - 25 mm spare conduits down to ceiling space from each flush panel. Terminate these conduits in 152 x 152 x 102 mm junction boxes in ceiling space or in case of an exposed concrete slab, terminate each conduit in flush concrete type box.
- .23 Remove and replace blocked conduit sections. Do not use liquids to clean out conduits.
- .24 Dry conduits out before installing wire.

3.3 SURFACE CONDUITS

- .1 Run parallel or perpendicular to building lines.
- .2 Locate conduits behind infrared or gas fired heaters with 1.5 m clearance.
- .3 Run conduits in flanged portion of structural steel.
- .4 Group conduits wherever possible on suspended channels.
- .5 Do not pass conduits through structural members except as indicated.
- .6 Do not locate conduits less than 75 mm parallel to steam or hot water lines with minimum of 25 mm at crossovers.

3.4 CONCEALED CONDUITS

- .1 Run parallel or perpendicular to building lines.
- .2 Do not install horizontal runs in masonry walls.
- .3 Do not install conduits in terrazzo or concrete toppings.

3.5 CONDUITS IN CAST-IN-PLACE CONCRETE

- .1 Locate to suit reinforcing steel. Install in centre one third of slab. Use rigid PVC conduit.
- .2 Protect conduits from damage where they stub out of concrete. Use rigid steel conduit for stub-up and adapt to in floor rigid PVC conduit.
- .3 Install sleeves where conduits pass through slab or wall.
- .4 Provide oversized sleeve for conduits passing through waterproof membrane, before membrane is installed. Use cold mastic between sleeve and conduit.
- .5 Do not place conduits in slabs in which slab thickness is less than 4 times conduit diameter.
- .6 Encase conduits completely in concrete with minimum 25 mm concrete cover.
- .7 Organize conduits in slab to minimize cross-overs.

3.6 CONDUITS IN CAST-IN-PLACE SLABS ON GRADE

- .1 Run conduits 25 mm and larger below slab and encased in 75 mm concrete envelope. Provide 50 mm of sand over concrete envelope below floor slab.

3.7 CONDUITS UNDERGROUND

- .1 Slope conduits to provide drainage.
- .2 Waterproof joints (PVC excepted) with heavy coat of bituminous paint.

3.8 CLEANING

- .1 Proceed in accordance with Section 01 74 11 – Cleaning.
- .2 On Completion and verification of performance of installation, remove surplus materials, excess materials rubbish, tools and equipment.

END OF SECTION

PART 1 - GENERAL

1.1 SUMMARY

- .1 This Section defines correction to maximum dry density to take into account aggregate particles larger than 4.75 mm.

1.2 REFERENCES

- .1 Codes and standards referenced in this section refers to the latest edition thereof. ASTM C127-88, Standard Test Method for Specific Gravity and Absorption of Coarse Aggregate.
- .2 ASTM D698, Standard Test Methods for Laboratory Compaction Characteristics of Soil Using Standard Effort (12,400 ft-lbf/ft³) (600kN-m/m³).
- .3 ASTM D1557, Test Method for Laboratory Compaction Characteristics of Soil Using Modified Effort (56,000 ft-lbf/ft³).
- .4 ASTM D4253, Standard Test Methods for Maximum Index Density and Unit Weight of Soils Using a Vibratory Table.

1.3 DEFINITIONS

- .1 Corrected maximum dry density is defined as:
 - .1 $D = (D1 \times D2) / (F1 \times D2) + (F2 \times D1)$
 - .2 Where: D = corrected maximum dry density kg/m³.
 - .1 F1 = fraction (decimal) of total field sample passing 4.75 mm sieve.
 - .2 F2 = fraction (decimal) of total field sample retained on 4.75 mm sieve (equal to 1.00 - F1)
 - .3 D1 = maximum dry density, kg/m³ of material passing 4.75 mm sieve determined in accordance with Method A C of ASTM D698.
 - .4 D2 = bulk density, kg/m³, of material retained on 4.75 mm sieve, equal to 1000G where G is bulk specific gravity (dry basis) of material when tested to ASTM C127.
 - .3 For free draining aggregates, determine D1 (maximum dry density) to ASTM D4253, dry method when directed by Engineer/Architect.

PART 2 - PRODUCTS (NOT APPLICABLE)

PART 3 - EXECUTION (NOT APPLICABLE)

END OF SECTION

PART 1 - GENERAL

1.1 RELATED SECTIONS

- .1 Section 01 33 00 – Submittal Procedures.
- .2 Section 31 23 10 – Excavating, Trenching and Backfilling
- .3 Section 32 11 23 – Aggregate Base Courses
- .4 Section 32 11 19 – Granular Sub-base
- .5 Section 32 12 18 – Asphalt Paving for Building Sites
- .6 Section 03 30 00 – Cast-in-Place Concrete.

1.2 REFERENCES

- .1 Codes and standards referenced in this section refers to the latest edition thereof.
- .2 American Society for Testing and Materials (ASTM International).
 - .1 ASTM D4791, Standard Test Method for Flat Particles, Elongated Particles, or Flat and Elongated Particles in Coarse Aggregate.

1.3 SOURCE QUALITY CONTROL

- .1 Source of materials to be incorporated into work or stockpiles requires approval.
- .2 Inform Engineer/Architect of proposed source of aggregates and provide access for sampling at least 4 weeks prior to commencing production.
- .3 If, in opinion of Engineer/Architect, materials from proposed source do not meet, or cannot reasonably be processed to meet, specified requirements, locate an alternative source or demonstrate that material from source in question can be processed to meet specified requirements.
- .4 Should a change of material source be proposed advise Engineer/Architect 4 weeks in advance of proposed change to allow sampling and testing.
- .5 Acceptance of material at source does not preclude future rejection if it is subsequently found to lack uniformity, or if its field performance is found to be satisfactory.

1.4 SAMPLES

- .1 Submit samples in accordance with Section 01 33 00 - Submittal Procedures.
- .2 Aggregate will be subject to continual sampling by Engineer/Architect during production.
- .3 Provide Engineer/Architect with access to source and processed material for sampling and testing.
- .4 Bear the cost of sampling and testing of aggregates which fail to meet specified requirements.

PART 2 - PRODUCTS

2.1 MATERIALS

- .1 Aggregate quality: sound, hard, durable material free from soft, thin, elongated or laminated particles, organic material, clay lumps or minerals, or other substances that would act in deleterious manner for use intended.
- .2 Flat and elongated particles of coarse aggregate: to ASTM D4791.
 - .1 Greatest dimension to exceed five times least dimension.
- .3 Fine aggregates satisfying requirements of applicable section to be one, or blend of following:
 - .1 Natural sand.
 - .2 Manufactured sand.
 - .3 Screenings produced in crushing of quarried rock, boulders, gravel or slag.
- .4 Coarse aggregates satisfying requirements of applicable section to be one of or blend of following:
 - .1 Crushed rock or slag.
 - .2 Gravel and crushed gravel composed of naturally formed particles of stone.

PART 3 - EXECUTION

3.1 TOPSOIL STRIPPING

- .1 Do not handle topsoil while in wet or frozen condition or in any manner in which soil structure is adversely affected.
- .2 Commence topsoil stripping of areas as indicated after area has been cleared and removed from site.
- .3 Strip topsoil to depths as indicated. Avoid mixing topsoil with subsoil.
- .4 Stockpile in locations as directed by Engineer/Architect. Stockpile height not to exceed 2.0 m.

3.2 DEVELOPMENT OF AGGREGATE SOURCE

- .1 Contractor to produce aggregates off site.
- .2 Contractor to develop aggregate source to prevent contamination of aggregates stockpiled.

3.3 PROCESSING

- .1 Process aggregate uniformly using methods that prevent contamination, segregation and degradation.
- .2 Blend aggregates, if required, to obtain gradation requirements, percentage of crushed particles, or particle shapes, as specified. Use methods and equipment approved by Engineer/Architect.
- .3 Wash aggregates, if required to meet specifications. Use only equipment approved by Engineer /Architect.
- .4 When operating in stratified deposits use excavation equipment and methods that produce uniform, homogeneous aggregate.

3.4 HANDLING

- .1 Handle and transport aggregates to avoid segregation, contamination and degradation.

3.5 STOCKPILING

- .1 Stockpile aggregates on site in locations as indicated unless directed otherwise by Engineer/Architect. Do not stockpile on completed pavement surfaces.
- .2 Stockpile aggregates in sufficient quantities to meet Project schedules.
- .3 Stockpiling sites to be level, well drained, and of adequate bearing capacity and stability to support stockpiled materials and handling equipment.
- .4 Except where stockpiled on acceptably stabilized areas, provide compacted sand base not less than 300 mm in depth to prevent contamination of aggregate. Stockpile aggregates on ground but do not incorporate bottom 300 mm of pile into work.
- .5 Separate different aggregates by strong, full depth bulkheads, or stockpile far enough apart to prevent intermixing.
- .6 Do not use intermixed or contaminated materials. Remove and dispose of rejected materials as directed by Engineer/Architect within 48 h of rejection.
- .7 Stockpile materials in uniform layers of thickness as follows:
 - .1 Max 1.0 m for coarse aggregate and base course materials.
 - .2 Max 2.0 m for fine aggregate and sub-base materials.
 - .3 Max 1.5 m for other materials.
- .8 Complete each layer over entire stockpile area before beginning next layer.
- .9 Uniformly spot-dump aggregates delivered to stockpile in trucks and build up stockpile as specified.
- .10 Do not cone piles or spill material over edges of piles.
- .11 Do not use conveying stackers.
- .12 During winter operations, prevent ice and snow from becoming mixed into stockpile or in material being removed from stockpile.

3.6 CLEANING

- .1 Leave aggregate stockpile site in tidy, well drained condition, free of standing surface water.
- .2 Leave any unused aggregates in neat compact stockpiles as directed by Engineer/Architect.

END OF SECTION

PART 1 - GENERAL

1.1 RELATED SECTIONS

- .1 Section 01 35 43 – Environmental Procedures.
- .2 Section 31 23 10 – Excavation, Trenching and Backfilling.
- .3 Section 31 23 17 – Rock Removal.

1.2 DEFINITIONS

- .1 Clearing consists of cutting off trees and brush vegetative growth to not more than a specified height above ground and disposing of felled trees, previously uprooted trees and stumps, and surface debris.
- .2 Close-cut clearing consists of cutting off standing trees, brush, scrub, roots, stumps and embedded logs, removing at, or close to, existing grade and disposing of fallen timber and surface debris.
- .3 Clearing isolated trees consists of cutting off to not more than specified height above ground of designated trees, and disposing of felled trees and debris.
- .4 Underbrush clearing consists of removal from treed areas of undergrowth, deadwood, and trees smaller than 50 mm trunk diameter and disposing of all fallen timber and surface debris.
- .5 Grubbing consists of excavation and disposal of stumps and roots boulders and rock fragments of specified size to not less than a specified depth below existing ground surface.

1.3 STORAGE AND PROTECTION

- .1 Prevent damage to fencing, trees, landscaping, natural features, bench marks, existing buildings, existing pavement, utility lines, site appurtenances, water courses, root systems of trees which are to remain.
- .2 Repair any damaged items to approval of Engineer/Architect. Replace any trees designated to remain, if damaged, as directed by Engineer/Architect.

PART 2 - PRODUCTS (NOT APPLICABLE)

PART 3 - EXECUTION

3.1 PREPARATION

- .1 Inspect site and verify with Engineer/Architect, items designated to remain.
- .2 Locate and protect utility lines. Preserve in operating condition active utilities traversing site.
- .3 Notify utility authorities before starting clearing and grubbing.

3.2 CLEARING

- .1 Clear as directed by Engineer/Architect, by cutting at a height of not more than 300 mm above ground. In areas to be subsequently grubbed, height of stumps left from clearing operations to be not more than 1000 mm above ground surface.
 - .2 Cut off branches and cut down trees overhanging area cleared as directed by Engineer/Architect.
 - .3 Cut off unsound branches on trees designated to remain as directed by Engineer/Architect.
- 3.3 CLOSE CUT CLEARING
- .1 Close cut clearing to ground level.
 - .2 Cut off branches down trees overhanging area cleared as directed by Engineer/Architect.
 - .3 Cut off unsound branches on trees designated to remain as directed by Engineer/Architect.
- 3.4 ISOLATED TREES
- .1 Cut off isolated trees as directed by Engineer/Architect at height of not more than 300 mm above ground surface.
 - .2 Grub out isolated tree stumps.
- 3.5 UNDERBRUSH CLEARING
- .1 Clear underbrush from areas as indicated at ground level.
- 3.6 GRUBBING
- .1 Grub out stumps and roots to not less than 200 mm below ground surface.
 - .2 Grub out visible rock fragments and boulders, greater than 300 mm in greatest dimension, but less than 0.25 m³.
- 3.7 REMOVAL AND DISPOSAL
- .1 Remove cleared and grubbed materials off site.
 - .2 Cut timber greater than 125 mm diameter to 3000 mm lengths and stockpile as indicated. Unless otherwise notified, stockpiled timber becomes property Owner.
 - .3 Dispose of cleared and grubbed materials off site.
 - .4 Remove diseased trees identified by Engineer/Architect and dispose of this material to approval of Engineer/Architect.
- 3.8 FINISHED SURFACE

- .1 Leave ground surface in condition suitable for immediate grading operations stripping of topsoil to approval of Engineer/Architect.

END OF SECTION

PART 1 - GENERAL

1.1 REFERENCES

- .1 Codes and standards referenced in this section refers to the latest edition thereof.
- .2 ASTM D 698, Test Method for Laboratory Compaction Characteristics of Soil Using Standard Effort (12,400ft-lbf/ft³) (600kN-m/m³)
- .3 CAN/CSA-A23.1, Concrete Materials and Methods of Concrete Construction.

1.2 SOIL REPORT

- .1 Examine soil report available from Engineer/Architect.

1.3 REGULATIONS

- .1 Shore and brace excavations, protect slopes and banks and perform all work in accordance with Provincial and Municipal regulations whichever is more stringent.
- .2 Comply with Explosives Act of Canada R.S., c.E-15, s.1. Perform blasting in accordance with Provincial and Municipal regulations. Repair damage to approval of Engineer/Architect. No blasting will be permitted within 3 m of any building and where damage would result.

1.4 TESTS AND INSPECTIONS

- .1 Testing of materials and compaction of backfill and fill will be carried out by testing laboratory designated by Engineer/Architect.
- .2 Not later than one week before backfilling or filling, provide to designated testing agency, 23 kg sample of backfill for fill material proposed for use.
- .3 Do not begin backfilling or filling operations until material has been approved for use by Engineer/Architect.
- .4 Not later than 48 hours before backfilling or filling with approved material, notify Engineer/Architect so that compaction tests can be carried out by designated testing agency.
- .5 Before commencing work, conduct, with Engineer/Architect, condition survey of existing structures, trees and other plants, lawns, fencing, service poles, wires, rail tracks and paving, survey bench marks and monuments which may be affected by work.

1.5 BURIED SERVICES

- .1 Before commencing work verify the location of all buried services on and adjacent to the site.
- .2 Arrange with appropriate authority for relocation of buried services that interfere with execution of work. Pay costs of relocating services.
- .3 Remove obsolete buried services within 2 m of foundations. Cap cut-offs.

1.6 PROTECTION

- .1 Protect excavations from freezing.
- .2 Keep excavations clean, free of standing water, and loose soil.
- .3 Where soil is subject to significant volume change due to change in moisture content, cover and protect to Engineer/Architect's Consultants approval.
- .4 Protect natural and man-made features required to remain undisturbed. Unless otherwise indicated or located in an area to be occupied by new construction, protect existing trees from damage.
- .5 Protect buried services that are required to remain undisturbed.

PART 2 - PRODUCTS

2.1 MATERIALS

- .1 Granular B-Type I, B-Type II, Select Subgrade to OPSS1010. Sand to OPSS1004.
- .2 Crushed Granular to CCDG14.02.
- .3 Unshrinkable fill: proportioned and mixed to provide:
 - .1 Maximum compressive strength of 0.4 MPa at 28 days.
 - .2 Maximum Portland cement content of 25 kg/m³.
 - .3 Minimum strength of 0.07 MPa at 24 h.
 - .4 Concrete aggregates: to CAN/CSA-A23.1,
 - .5 Portland cement: Type 10.
 - .6 Slump: 160 to 200 mm.

PART 3 - EXECUTION

3.1 CLEARING AND GRUBBING

- .1 Remove trees, stumps, logs, brush, shrubs, bushes, vines, undergrowth, rotten wood, dead plant material, exposed boulders and debris within areas designated on drawings.
- .2 Remove stumps and tree roots below footings, slabs, and paving, and to 600 mm below finished grade elsewhere.
- .3 Dispose of cleared and grubbed material off site daily to disposal areas acceptable to authority having jurisdiction.

3.2 EXCAVATION

- .1 Strip topsoil over areas to be covered by new construction, over areas where grade changes are required, and so that excavated material may be stockpiled without covering topsoil. Stockpile topsoil on site for later use.

- .2 Excavate as required to carry out work, in all materials met. Do not disturb soil or rock below bearing surfaces. Notify Engineer/Architect when excavations are complete. If bearings are unsatisfactory, additional excavation will be authorized in writing and paid for as additional work. Excavation taken below depths shown without Engineer/Architect written authorization to be filled with concrete of same strength as for footings at Contractor's expense.
- .3 Excavate trenches to provide uniform continuous bearing and support for 150 mm thickness of pipe bedding material on solid and undisturbed ground. Trench widths below point 150 mm above pipe not to exceed diameter of pipe plus 600 mm.
- .4 Excavate for slabs and paving to subgrade levels. In addition, remove all topsoil, organic matter, debris and other loose and harmful matter encountered at subgrade level.

3.3 BACKFILLING

- .1 Inspection: do not commence backfilling until fill material and spaces to be filled have been inspected and approved by Engineer/Architect.
- .2 Remove snow, ice, construction debris, organic soil and standing water from spaces to be filled.
- .3 Lateral support: maintain even levels of backfill around structures as work progresses, to equalize earth pressures.
- .4 Compaction of subgrade: compact existing subgrade under walks, paving, and slabs on grade, to same compaction as specified for fill. Fill excavated areas with selected subgrade material or gravel and sand compacted as specified for fill.
- .5 Placing:
 - .1 Place backfill, fill and base course material in 150 mm lifts. Add water as required to achieve specified density.
- .6 Compaction: compact each layer of material to following densities for material to ASTM D698,
 - .1 To underside of base courses: 95%.
 - .2 Base courses: 100%.
 - .3 Elsewhere: 90%.
- .7 In trenches:
 - .1 Up to 300 mm above pipe or conduit: sand placed by hand.
 - .2 Over 300 mm above pipe or conduit: native material approved by Engineer/Architect.
- .8 Under seeded and sodded areas: use site excavated material to bottom of topsoil except in trenches and within 600 mm of foundations.
- .9 Blown rock material, not capable of fine grading, is not acceptable, imported material must be placed on this type of material.
- .10 Against foundations (except as applicable to trenches and under slabs and paving): excavated material or imported material with no stones larger than 200 mm diameter within 600 mm of structures.

- .11 Underground tanks: use sand to bottom of granular base courses or to bottom of topsoil, as applicable.

3.4 GRADING

- .1 Grade so that water will drain away from buildings, walls and paved areas, to catch basins and other disposal areas approved by the Engineer/Architect. Grade to be gradual between finished spot elevations shown on drawings.

3.5 SHORTAGE AND SURPLUS

- .1 Supply all necessary fill to meet backfilling and grading requirements and with minimum and maximum rough grade variance.
- .2 Dispose of surplus material off site.

END OF SECTION

PART 1 - GENERAL

1.1 RELATED SECTIONS

- .1 Section 01 33 00 – Submittal Procedures.
- .2 Section 01 56 00 – Temporary Barriers and Enclosures.
- .3 Section 01 35 43 – Environmental Procedures.
- .4 Section 31 23 13 – Rough Grading.
- .5 Section 31 23 17 – Rock Removal.
- .6 Section 31 05 17 – Aggregate Materials.

1.2 REFERENCES

- .1 Codes and standards referenced in this section refers to the latest edition thereof.
- .2 American Society for Testing and Materials (ASTM).
 - .1 ASTM C117, Standard Test Method for Material Finer Than 0.075 mm (No. 200) Sieve in Mineral Aggregates by Washing.
 - .2 ASTM C136, Standard Test Method for Sieve Analysis of Fine and Coarse Aggregates.
 - .3 ASTM D698, Standard Test Method for Laboratory Compaction Characteristics of Soil Using Standard Effort (12,400 ft-lbf/ft³) (600 kN-m/m³).
 - .4 ASTM D1557, Test Method for Laboratory Compaction Characteristics of Soil Using Modified Effort (56,000 ft-lbf/ft³) (2,700 kN-m/m³).
- .3 Canadian General Standards Board (CGSB).
 - .1 CAN/CGSB-8.1, Sieves, Testing, Woven Wire, Inch Series.
 - .2 CA/CGSB-8.2, Sieves, Testing, Woven Wire, Metric
- .4 Canadian General Standards Association (CSA)
 - .1 CAN/CSA-A23.1, Concrete Materials and Methods of Concrete Construction.

1.3 DEFINITIONS

- .1 Excavation classes: two classes of excavation will be recognized; common excavation and rock excavation.
 - .1 Rock excavation: excavation of material from solid masses of igneous, sedimentary or metamorphic rock which, prior to its removal, was integral with its parent mass, and boulders or rock fragments having individual volume in excess of 1 m³. Frozen material not classified as rock.
 - .2 Common excavation: excavation of materials of whatever nature, which are not included under definitions of rock excavation.
- .2 Unclassified excavation: excavation of deposits of whatever character encountered in work.

- .3 Topsoil: material capable of supporting good vegetative growth and suitable for use in top dressing, landscaping and seeding.
- .4 Waste material: excavated material unsuitable for use in work or surplus to requirements.
- .5 Borrow material: material obtained from locations outside area to be graded, and required for construction of fill areas or for other portions of work.
- .6 Unsuitable materials:
 - .1 Weak and compressible materials under excavated areas.
 - .2 Frost susceptible materials under excavated areas.
 - .3 Frost susceptible materials:
 - .1 Fine grained soils with plasticity index less than 10 when tested to ASTM D4318, and gradation within limits specified when tested to ASTM D422 and ASTM C136: Sieve sizes to CAN/CGSB-8.1.

Sieve Designation	% Passing
2.00 mm	100
0.10 mm	45-100
0.02 mm	10-80
0.005 mm	0-45

- .2 Coarse grained soils containing more than 20% by mass passing 0.075 mm sieve.

1.4 SUBMITTALS

- .1 Submit samples in accordance with Section 01 33 00 – Submittal Procedures.
- .2 Inform Engineer/Architect at least 4 weeks prior to commencing work, of proposed source of fill materials and provide access for sampling.
- .3 Submit 70 kg samples of type of fill specified including representative samples of excavated material.
- .4 Ship samples as directed by Engineer/Architect in tightly closed containers to prevent contamination.

1.5 QUALITY ASSURANCE

- .1 Submit design and supporting data at least 2 weeks prior to commencing work.
- .2 Design and supporting data submitted to bear stamp and signature of qualified professional engineer registered or licensed in the province of Newfoundland and Labrador.
- .3 Keep design and supporting data on site.
- .4 Engage services of qualified professional engineer who is registered or licensed in Province of Newfoundland and Labrador to design and inspect cofferdams, shoring, bracing and underpinning required for work.

1.6 PROTECTION OF EXISTING FEATURES

- .1 Protect existing features in accordance with Section 01 56 00 - Temporary Barriers and Enclosures and applicable local regulations.
- .2 Existing buried utilities and structures:
 - .1 Size, depth and location of existing utilities and structures as indicated are for guidance only. Completeness and accuracy are not guaranteed.
 - .2 Prior to commencing excavation work, notify applicable Owner or authorities having jurisdiction, establish location and state of use of buried utilities and structures. Owners or authorities having jurisdiction to clearly mark such locations to prevent disturbance during work.
 - .3 Confirm locations of buried utilities by careful test excavations.
 - .4 Maintain and protect from damage, water, sewer, gas, electric, telephone and other utilities and structures encountered as indicated.
 - .5 Where utility lines or structures exist in area of excavation, obtain direction of Engineer/Architect before removing or re-routing.
 - .6 Record location of maintained, re-routed and abandoned underground lines.
 - .7 Confirm locations of recent excavations adjacent to area of excavation.
- .3 Existing buildings and surface features:
 - .1 Conduct, with Engineer/Architect condition survey of existing buildings, trees and other plants, lawns, fencing, service poles, wires, rail tracks, pavement, survey bench marks and monuments which may be affected by work.
 - .2 Protect existing buildings and surface features from damage while work is in progress. In event of damage, immediately make repair to approval of Engineer/Architect.
 - .3 Where required for excavation, cut roots or branches as approved by Engineer/Architect.

PART 2 - PRODUCTS

2.1 MATERIALS

- .1 Backfill Type 1 and Type 2 fill: properties to Section 31 05 17 – Aggregate Materials and the following requirements:
 - .1 Crushed, pit run or screened stone, gravel or sand.
 - .2 Gradations to be within limits specified when tested to ASTM C136 and ASTM C117. Sieve sizes to CAN/CGSB-8.1.

Sieve Designation	%Passing	
	Type1	Type2
75 mm	-	100
50 mm	-	-
37.5 mm	-	-
25 mm	100	-
19 mm	75-100	-
12.5 mm	-	-
9.5 mm	50-100	-
4.75 mm	30-70	22-85
2.00 mm	20-45	-

0.425 mm	10-25	5-30
0.180 mm	-	-
0.075 mm	3-8	0-10

- .2 Type 3 fill: selected material from excavation or other sources, approved by Engineer/Architect for use intended, unfrozen and free from rocks larger than 75 mm, cinders, ashes, sods, refuse or other deleterious materials.

PART 3 - EXECUTION

3.1 SITE PREPARATION

- .1 Remove obstructions, ice and snow, from surfaces to be excavated within limits indicated.

3.2 STRIPPING OF TOPSOIL

- .1 Commence topsoil stripping of areas as indicated by Engineer/Architect after area has been cleared of brush, weeds and grasses and removed from site.
- .2 Strip topsoil to depths as indicated by Engineer/Architect. Do not mix topsoil with subsoil.
- .3 Stockpile in locations as directed by Engineer/Architect. Stockpile height not to exceed 2 m.
- .4 Dispose of unused topsoil as directed by Engineer/Architect.

3.3 STOCKPILING

- .1 Stockpile fill materials in areas designated by Engineer/Architect. Stockpile granular materials in manner to prevent segregation.
- .2 Protect fill materials from contamination.

3.4 COFFERDAMS, SHORING, BRACING AND UNDERPINNING

- .1 Obtain permit from authority having jurisdiction for temporary diversion of water course.
- .2 Construct temporary works to depths, heights and locations as indicated or approved by Engineer/Architect.
- .3 During backfill operation:
 - .1 Unless otherwise as indicated or as directed by Engineer/Architect remove sheeting and shoring from excavations.
 - .2 Do not remove bracing until backfilling has reached respective levels of such bracing.
 - .3 Pull sheeting in increments that will ensure compacted backfill is maintained at an elevation at least 500 mm above toe of sheeting.
- .4 When sheeting is required to remain in place, cut off tops at elevations as indicated.
- .5 Upon completion of substructure construction:
 - .1 Remove cofferdams, shoring and bracing.

- .2 Remove excess materials from site and restore water courses as indicated and as directed by Engineer/Architect.

3.5 DEWATERING AND HEAVE PREVENTION

- .1 Keep excavations free of water while work is in progress.
- .2 Submit for Engineer/Architect's review details of proposed dewatering or heave prevention methods, such as dikes, well points, and sheet pile cut-offs.
- .3 Avoid excavation below groundwater table if quick condition or heave is likely to occur. Prevent piping or bottom heave of excavations by groundwater lowering, sheet pile cut-offs, or other means.
- .4 Protect open excavations against flooding and damage due to surface run-off.
- .5 Dispose of water in accordance with Section 01 35 43 – Environmental Procedures and in manner not detrimental to public and private property, or any portion of work completed or under construction.
- .6 Provide flocculation tanks, settling basins, or other treatment facilities to remove suspended solids or other materials before discharging to storm sewers, water courses or drainage areas.

3.6 EXCAVATION

- .1 Excavate to lines, grades, elevations and dimensions as indicated by Engineer/Architect.
- .2 Remove concrete, masonry, paving, walks, demolished foundations and rubble and other obstructions encountered during excavation in accordance with Section 02 41 23 – Selective Site Demolition and Removal.
- .3 Excavation must not interfere with bearing capacity of adjacent foundations.
- .4 Do not disturb soil within branch spread of trees or shrubs that are to remain. If excavating through roots, excavate by hand and cut roots with sharp axe or saw.
- .5 For trench excavation, unless otherwise authorized by Engineer/Architect in writing, do not excavate more than 30 m of trench in advance of installation operations and do not leave open more than 15 m at end of day's operation.
- .6 Keep excavated and stockpiled materials a safe distance away from edge of trench as directed by Engineer/Architect.
- .7 Restrict vehicle operations directly adjacent to open trenches.
- .8 Dispose of surplus and unsuitable excavated material off site.
- .9 Do not obstruct flow of surface drainage or natural watercourses.
- .10 Earth bottoms of excavations to be undisturbed soil, level, free from loose, soft or organic matter.
- .11 Notify Engineer/Architect when bottom of excavation is reached.

- .12 Obtain Engineer/Architect approval of completed excavation.
- .13 Remove unsuitable material from trench bottom to extent and depth as directed by Engineer/Architect.
- .14 Correct unauthorized over-excavation as follows:
 - .1 Fill under bearing surfaces and footings with concrete specified for footings.
 - .2 Fill under other areas with Type 2 fill compacted to not less than 95% of corrected maximum dry density.
- .15 Hand trim, make firm and remove loose material and debris from excavations. Where material at bottom of excavation is disturbed, compact foundation soil to density at least equal to undisturbed soil. Clean out rock seams and fill with concrete mortar or grout to approval of Engineer/Architect.

3.7 FILL TYPES AND COMPACTION

- .1 Use fill of types as indicated or specified below. Compaction densities are percentages of maximum densities obtained from ASTM D698 corrected maximum dry density.
 - .1 Exterior side of perimeter walls: use Type 3 fill to subgrade level. Compact to 95%.
 - .2 Within building area: use Type 2 to underside of base course for floor slabs. Compact to 98%.
 - .3 Under concrete slabs: provide 150 mm compacted thickness base course of Type 1 fill to underside of slab. Compact base course to 100%.
 - .4 Retaining walls: use Type 2 fill to subgrade level on high side for minimum 500 mm from wall and compact to 95%. For remaining portion, use Type 3 fill compacted to 95%.
 - .5 To correct over excavation in trenches: use Type 2 fill to underside of sand bedding compacted to 95%.

3.8 BEDDING AND SURROUND OF UNDERGROUND SERVICES

- .1 Place and compact granular material for bedding and surround of underground services as indicated.
- .2 Place bedding and surround material in unfrozen condition.

3.9 BACKFILLING

- .1 Vibratory compaction equipment: approved by Engineer/Architect.
- .2 Do not proceed with backfilling operations until Engineer/Architect has inspected and approved installations.
- .3 Areas to be backfilled to be free from debris, snow, ice, water and frozen ground.
- .4 Do not use backfill material which is frozen or contains ice, snow or debris.
- .5 Place backfill material in uniform layers not exceeding 150 mm compacted thickness up to grades indicated. Compact each layer before placing succeeding layer.
- .6 Backfill around installations.
 - .1 Place bedding and surround material as specified elsewhere.
 - .2 Do not backfill around or over cast-in-place concrete within 24 hours after placing of concrete.
 - .3 Place layers simultaneously on both sides of installed work to equalize loading. Difference not to exceed 600 mm.

- .4 Where temporary unbalanced earth pressures are liable to develop on walls or other structures.
 - .1 Permit concrete to cure for minimum 14 days or until it has sufficient strength to withstand earth and compaction pressure, and approval obtained from Engineer/Architect, or
 - .2 If approved by Engineer/Architect, erect bracing or shoring to counteract unbalance, and leave in place until removal is approved by Engineer/Architect.

3.10 RESTORATION

- .1 Upon completion of work, remove waste materials and debris, trim slopes, and correct defects as directed by Engineer/Architect.
- .2 Replace topsoil as indicated by Engineer/Architect.
- .3 Reinstall lawns to elevation which existed before excavation.
- .4 Reinstall pavement and sidewalks distributed by excavation to thickness, structure, and elevation which existed before excavation.
- .5 Clean and reinstall areas affected by work as directed by Engineer/Architect.
- .6 Use temporary plating to support traffic loads over unshrinkable fill for initial 24 h.

END OF SECTION

PART 1 - GENERAL

1.1 RELATED SECTIONS

- .1 Section 31 11 00 – Clearing and Grubbing.
- .2 Section 31 23 10 – Excavation, Trenching and Backfilling.
- .3 Section 31 23 17 – Rock Removal.

1.2 REFERENCES

- .1 Codes and standards referenced in this section refers to the latest edition thereof.
- .2 ASTM D698-91, Test Method for Laboratory Compaction Characteristics of Soil Using Standard Effort (600kN-m/m³).

1.3 EXISTING CONDITIONS

- .1 Examine subsurface investigation report which is available for inspection from Engineer/Architect.
- .2 Known underground and surface utility lines and buried objects are as indicated on site plan.
- .3 Refer to dewatering in Section 31 23 10 – Excavating Trenching and Backfilling.

1.4 PROTECTION

- .1 Protect and/or transplant existing fencing trees, landscaping, natural features, bench marks, buildings, pavement, surface or underground utility lines which are to remain as directed by Engineer/Architect. If damaged, restore to original or better condition unless directed otherwise.
- .2 Maintain access roads to prevent accumulation of construction related debris on roads.

PART 2 - PRODUCTS

2.1 MATERIALS

- .1 Fill material: Type 3 in accordance with of Section 31 23 10 – Excavating, Trenching and Backfilling.
- .2 Excavated or graded material existing on site may be suitable to use as fill for grading work if approved by Engineer/Architect.

PART 3 - EXECUTION

3.1 STRIPPING OF TOPSOIL

- .1 Do not handle topsoil while in wet or frozen condition or in any manner in which soil structure is adversely affected as determined by Engineer/Architect.

- .2 Commence topsoil stripping of areas as indicated after area has been cleared of brush, weeds and grasses and removed from site.
- .3 Strip topsoil to depths as indicated. Avoid mixing topsoil with subsoil.
- .4 Stockpile in locations as directed by Engineer/Architect. Stockpile height not to exceed 2 m.
- .5 Dispose of unused topsoil as directed by Engineer/Architect.

3.2 GRADING

- .1 Rough grade to levels, profiles, and contours allowing for surface treatment as indicated.
- .2 Rough grade to following depths below finish grades:
 - .1 .250mm for concrete slabs and walks precast paving units.
 - .3 Slope rough grade away from building 1:50 minimum.
 - .4 Grade ditches to depth as indicated.
 - .5 Prior to placing fill over existing ground, scarify surface to depth of 150 mm. Maintain fill and existing surface at approximately same moisture content to facilitate bonding.
 - .6 Compact filled and disturbed areas to corrected maximum dry density to ASTM D698, as follows:
 - .1 85% under landscaped areas.
 - .2 95% under paved and walk areas.
 - .7 Do not disturb soil within branch spread of trees or shrubs to remain.

3.3 TESTING

- .1 Inspection and testing of soil compaction will be carried out by testing laboratory designated by Engineer/Architect. Refer to Sections 01 29 83 - Payment Procedures for Testing Laboratory Services and 01 45 00 – Quality Control.
- .2 Submit testing procedure, frequency of tests, to Engineer/Architect for approval.

3.4 SURPLUS MATERIAL

- .1 Remove surplus material and material unsuitable for fill, grading or landscaping as directed by Engineer/Architect.

END OF SECTION

PART 1 - GENERAL

1.1 RELATED SECTIONS

- .1 Section 01 33 00 - Submittal Procedure.
- .2 Section 01 56 00 - Temporary Barriers and Enclosures.
- .3 Section 01 35 29.06 - Health and Safety Requirements
- .4 Section 31 23 10 - Excavating, Trenching and Backfilling.

1.2 DEFINITION

- .1 Rock: any solid material in excess of 1.0m³ and which cannot be removed by means of mechanical excavating equipment having 0.95 to 1.15m³ bucket. Frozen material not classified as rock.
- .2 PPV: peal particle velocity.

1.3 MEASUREMENT PROCEDURES

- .1 Mass rock:
 - .1 Rock quantities will be taken from cross section showing original rock surface and actual grade line set by Engineer/Architect, except that minimum depth or rock required to be excavated to be considered as 300 mm.
 - .2 Volume of individual boulders and rock fragments will be determined by measuring three maximum mutually perpendicular dimensions.
- .2 Trench rock: rock quantities measured will be actual volume removed within following limits:
 - .1 Width for trench excavation as indicated.
 - .2 Width for excavation for structures to be bounded by vertical planes up to 500 mm outside and parallel to neat lines for footings as indicated.
 - .3 Depth from rock surface elevations immediately prior to excavation, to elevation as indicated.
 - .4 Where design elevation is less than 300 mm below original rock surface depth will be considered to be 300 mm below original rock surface.
- .3 Replacement imported fill: Imported fill quantities will be measured in cubic meters, compacted in place.
- .4 Quantities for measurement purposes are indicated in Tender Form. If no quantities are provided, rock removal and fill replacement considered inclusive to the work and will not be measured.
- .5 Contractors shall provide all survey equipment needed and provide assistance to Engineer/Architect in taking cross sections. Sections shall be taken at 5 m intervals for mass and trench rock excavation. Sections will be submitted to contractor's site representative for verification. Additional sections shall be taken at points or significant change in elevation or at any other locations as determined by Engineer/Architect. Contractor to schedule work to allow sufficient time for Engineer/Architect to take necessary sections.

1.4 SUBMITTALS

.1 Blasting Operation

- .1 Submit to Engineer/Architect and local authorities having jurisdiction for approval, written proposal of operations for removal of rock by blasting, in accordance with Section 01 33 00 - Submittal Procedures.
- .2 Indicate proposed method of carrying out work types and quantities of explosives to be used, loading charts and drill hole patterns, type of caps, blasting techniques, blast protection measures for items such as flying rock, vibration, dust and noise control. Include details on protective measures, time of blasting and other pertinent details.
- .3 Submit records to Engineer/Architect at end of each shift. Maintain complete and accurate records for drilling and blasting operations.
- .4 Prior to any blasting operations, the contractor shall carry out a pre-blast survey. This survey will be conducted by an independent agency. The survey report will be submitted to the Engineer/Architect for review/
- .5 No blasting shall take place without a minimum of 48 hours' notice to the Engineer/Architect.

1.5 QUALIFICATIONS

- .1 Retain licensed explosives expert to program and supervise blasting work, to interpret recommendations of pre-blasting report, and to determine precautions, preparation and operations techniques.

1.6 BLASTING AND VIBRATION CONTROL

- .1 Reduce ground vibrations to avoid damage to structures or remaining rock mass.

PART 2 - PRODUCTS (NOT APPLICABLE)

PART 3 - EXECUTION

3.1 PROTECTION

- .1 Prevent damage to surroundings and injury to persons in accordance with Section 01 56 00 - Temporary Barriers and Enclosures. Sound warnings and display signs when blasting to take place.

3.2 ROCK REMOVAL

- .1 Coordinate this Section with Section 01 35 29.06 - Health and Safety Requirements.
- .2 Remove rock to alignments, profiles, and cross sections as indicated.
- .3 Explosive blasting is not permitted at locations indicated.
- .4 Do blasting operations in accordance with local and provincial codes, requirements of authority having jurisdiction.
- .5 Use rock removal procedures to produce uniform and stable excavation surfaces. Minimize over break, and to avoid damage to adjacent structures.
- .6 Excavate rock to horizontal surfaces.

- .7 Scale, pressure wash and broom clean rock surfaces which are to bond to concrete.
 - .8 Excavate trenches to lines and grades to minimum of 300 mm below pipe invert indicated. Provide recesses for bell and spigot pipe to ensure bearing will occur uniformly along barrel of pipe.
 - .9 Cut trenches to widths as indicated.
 - .10 Use pre-shearing, cushion blasting or other smooth wall drilling and blasting techniques directed by Engineer/Architect.
 - .11 Remove boulders and fragments which may slide or roll into excavated areas.
 - .12 Correct unauthorized rock removal at no extra cost, in accordance with Section 31 23 10 - Excavating, Trenching and Backfilling.
- 3.3 ROCK DISPOSAL
- .1 Dispose of surplus removed rock off site. Dispose in locations acceptable to authorities having jurisdiction and Engineer/Architect.

END OF SECTION

PART 1 - GENERAL

1.1 RELATED SECTIONS

- .1 Section 31 23 10 – Excavating, Trenching and Backfilling
- .2 Section 31 05 17 – Aggregate Materials
- .3 Section 32 11 23 – Aggregate Base Courses

1.2 REFERENCES

- .1 Codes and standards referenced in this section refers to the latest edition thereof.
- .2 American Society for Testing and Materials (ASTM).
 - .1 ASTM C117, Standard Test Method for Material Finer Than 0.075 mm Sieve in Mineral Aggregates by Washing.
 - .2 ASTM C136, Standard Test Method for Sieve Analysis of Fine and Course Aggregates.
 - .3 ASTM D698, Stand Test Methods for Laboratory Compaction Characteristics of Soil Using standard Effort (12,400 ft-lbf/ft³)1557-00, (2,700 kN-m/m³).
 - .4 ASTM D1557, Test Method for Laboratory Compaction Characteristics of Soil Using Modified Effort (56,000 ft-lbf/ft³) (2,700 kN-m/m³).
 - .5 ASTM D4318, Standard Test Methods for Liquid Unit, Plastic Unit and Plasticity Index of Soils.
- .3 Canadian General Standards Board (CGSB)
 - .1 CAN/CGSB-8.1, Sieves, Testing, Woven-Wire, Inch Series.
 - .2 CAN/CGSB-8.2, Sieves, Testing, Woven Wire, Metric.

PART 2 - PRODUCTS

2.1 MATERIALS

- .1 Granular base: material to Section 31 05 17 – Aggregate Materials and the following requirements:
 - .1 Crushed pit run or screened stone, gravel or sand.
 - .2 Granulations to be within limits specified when tested to ASTM C136 and ASTM C117. Sieve sizes to CAN/CGSB-8.1.
 - .1 Granulation to:

Sieve Designation	% Passing (Base Type 1)
100 mm	-
75 mm	-
50 mm	100
37.5 mm	-
25 mm	60-100
19 mm	-
12.5 mm	38-70
9.5 mm	-
4.75 mm	25-55
2.00 mm	13-42

0.425 mm	5-28
0.180 mm	-
0.075 mm	2-10

- .3 Other properties as follows:
 - .1 Liquid limit: to ASTM D4318, maximum 25
 - .2 Plasticity index: to ASTM D4318, maximum 6

PART 3 - EXECUTION

3.1 PLACING

- .1 Place granular sub-base after subgrade is inspected and approved by Engineer/Architect.
- .2 Construct granular sub-base to depth and grade in areas indicated.
- .3 Ensure no frozen material is placed.
- .4 Place material only on clean unfrozen surface, free from snow and ice.
- .5 Place granular sub-base material using methods which do not lead to segregation or degradation.
- .6 Place material to full width in uniform layers not exceeding 150 mm compacted thickness. Engineer/Architect may authorize thicker lifts (layers) if specified compaction can be achieved.
- .7 Shape each layer to smooth contour and compact to specified density before succeeding layer is placed.
- .8 Remove and replace that portion of layer in which material becomes segregated during spreading.

3.2 COMPACTION

- .1 Compaction equipment to be capable of obtaining required material densities.
- .2 Compact to density not less than 98% corrected maximum dry density ASTM D698
- .3 Shape and roll alternately to obtain smooth, even and uniformly compacted sub-base.
- .4 Apply water as necessary during compacting to obtain specified density.
- .5 In areas not accessible to rolling equipment, compact to specified density with mechanical tampers approved by Engineer/Architect.
- .6 Correct surface irregularities by loosening and adding or removing material until surface is within specified tolerance.

3.3 SITE TOLERANCES

- .1 Finished sub-base surface to be within 10 mm of elevation as indicated but not uniformly high or low.

3.4 PROTECTION

- .1 Maintain finished sub-base in condition conforming to this section until succeeding base is constructed or until granular sub-base is accepted by Engineer/Architect.

END OF SECTION

PART 1 - GENERAL

1.1 RELATED SECTIONS

- .1 Section 31 05 17 – Aggregate Materials
- .2 Section 32 11 19 – Granular Sub-base.

1.2 REFERENCES

- .1 Codes and standards referenced in this section refers to the latest edition thereof.
- .2 American Society for Testing and Materials (ASTM).
 - .1 ASTM C117, Standard Test Method for Material Finer Than 0.075 mm Sieve in Mineral Aggregates by Washing.
 - .2 ASTM C136, Standard Test Method for Resistance to Degradation of Small-Size Coarse Aggregate by Abrasion and Impact in the Los Angeles Machine.
 - .3 ASTM D136, Standard Test Method for Sieve Analysis of Fine and Course Aggregated.
 - .4 ASTM D698, Stand Test Methods for Laboratory Compaction Characteristics of Soil Using standard Effort (12,400 ft-lbf/ft³)1557-00, (2,700 kN-m/m³).
 - .5 ASTM D1557, Test Method for Laboratory Compaction Characteristics of Soil Using Modified Effort (56,000 ft-lbf/ft³) (2,700 kN-m/m³).
 - .6 ASTTM D 1883, Standard Test Method of CBR (California Bearing Ratio) of Laboratory Compacted Soil.
 - .7 ASTM D4318, Standard Test Methods for Liquid Unit, Plastic Unit and Plasticity Index of Soils.
- .3 Canadian General Standards Board (CGSB)
 - .1 CAN/CGSB-8.1, Sieves, Testing, Woven-Wire, Inch Series.
 - .2 CAN/CGSB-8.2, Sieves, Testing, Woven Wire, Metric.

1.3 DELIVERY, STORAGE, AND HANDLING

- .1 Deliver and stockpile aggregates in accordance with Section 31 05 17 – Aggregate Materials. Stockpile minimum 50% of total aggregate required prior to commencing operation.
- .2 Store cement in weathertight bins or silos that provide protection from dampness and easy access for inspection and identification of each shipment.

PART 2 - PRODUCTS

2.1 MATERIALS

- .1 Granular base: material to Section 31 05 17 – Aggregate Materials and the following requirements:
 - .1 Crushed stone or gravel.
 - .2 Granulations to be within limits specified when tested to ASTM C136 and ASTM C117. Sieve sizes to CAN/CGSB-8.1.
- .1 Granulation to:

Sieve Designation	% Passing (Base Type 1)
100 mm	-
75 mm	-
50 mm	-
37.5 mm	-
25 mm	-
19 mm	100
12.5 mm	70-100
9.5 mm	-
4.75 mm	40-70
2.00 mm	23-50
0.425 mm	7-25
0.180 mm	-
0.075 mm	3-8

- .3 Liquid limit: to ASTM D4318, maximum 25
- .4 Plasticity index: to ASTM D4318 maximum 6
- .5 Los Angeles degranulation: to ASTM C131. Maximum % loss by weight 45.
- .6 Crushed particles: at least 60% of particles by mass within each of following sieve designation ranges to have at least 1 (one) freshly fractured face. Materials to be divided into ranges using methods of ASTM C136.

Passing	to	Retained on
50 mm	to	25 mm
25 mm	to	19 mm
19 mm	to	4.75 mm

- .7 Soaked CBR to ASTM D1833, min 100 when compacted to 100% of ASTM D1557.

PART 3 - EXECUTION

3.1 SEQUENCE OF OPERATION

- .1 Place granular base after granular sub base surface is inspected and approved by Engineer/Architect.
 - .1 Construct granular base to depth and grade in areas indicated.
 - .2 Ensure no frozen material is placed.
 - .3 Place material only on clean unfrozen surface, free from snow and ice. slope.
 - .4 Place material using methods which do not lead to segregation or degradation of aggregate.
 - .5 Place material to full width in uniform layers not exceeding 150 mm compacted thickness. Engineer/Architect may authorize thicker lifts (layers) if specified compaction can be achieved.
 - .6 Shape each layer to smooth contour and compact to specified density before succeeding layer is placed.
 - .7 Remove and replace that portion of layer in which material becomes segregated during spreading.
- .2 Compaction Equipment
 - .1 Compaction equipment to be capable of obtaining required material densities.
- .3 Compacting
 - .1 Compact to density not less than 100% corrected maximum dry density ASTM D698

- .2 Shape and roll alternately to obtain smooth, even and uniformly compacted base.
- .3 Apply water as necessary during compacting to obtain specified density.
- .4 In areas not accessible to rolling equipment, compact to specified density with mechanical tampers approved by Engineer/Architect.
- .5 Correct surface irregularities by loosening and adding or removing material until surface is within specified tolerance.

3.2 SITE TOLERANCES

- .1 Finished base surface to be within plus or minus 10 mm of established grade and cross section but not uniformly high or low.

3.3 PROTECTION

- .1 Maintain finished base in condition conforming to this section until succeeding material is applied or until acceptance by Engineer/Architect.

END OF SECTION

PART 1 - GENERAL

1.1 SECTION INCLUDES

- .1 Materials and installation for asphalt concrete pavement for car park areas, driveways to buildings, and walks or play areas.

1.2 RELATED SECTIONS

- .1 Section 01 33 00 – Submittal Procedures.
- .2 Section 01 45 00 – Quality Control.
- .3 Section 31 05 16 – Aggregate Materials.
- .4 Section 31 23 33.01 – Excavating, Trenching and Backfilling.
- .5 Section 32 16 15 – Concrete Walks, Curbs and Gutters.
- .6 Section 32 17 23 – Pavement Marking.

1.3 REFERENCES

- .1 Codes and Standards referenced in this section refer to the latest edition thereof.
- .2 Canadian General Standards Board (CGSB)
 - .1 CAN/CGSB-8.1, Sieves Testing, Woven Wire, Inch Series.
 - .2 CAN/CGSB-8.2, Sieves Testing, Woven Wire, Metric.
 - .3 CAN/CGSB-16.1, Cutback Asphalts for Road Purposes.
 - .4 CAN/CGSB-16.2, Emulsified Asphalts, Anionic Type, for Road Purposes.
 - .5 CAN/CGSB-16.3, Asphalt Cements for Road Purposes.
- .3 American Society for Testing and Materials International, (ASTM)

- .1 ASTM C88, Standard Test Method for Soundness of Aggregates by Use of Sodium Sulphate or Magnesium Sulphate.
 - .2 ASTM C117, Standard Test Method for Material Finer Than 0.075 mm (No. 200) Sieve in Mineral Aggregates by Washing.
 - .3 ASTM C123, Standard Test Method for Lightweight Particles in Aggregate.
 - .4 ASTM C127, Standard Test Method for Density, Relative Density (Specific Gravity), and Absorption of Coarse Aggregate.
 - .5 ASTM C128, Standard Test Method for Density, Relative Density (Specific Gravity), and Absorption of Fine Aggregate.
 - .6 ASTM C131, Standard Test Method for Resistance to Degradation of Small-Size Coarse Aggregate by Abrasion and Impact in the Los Angeles Machine.
 - .7 ASTM C136, Standard Method for Sieve Analysis of Fine and Coarse Aggregates.
 - .8 ASTM D698, Standard Test Method for Laboratory Compaction Characteristics of Soil Using Standard Effort (12,400 ft-lbf/ft³) (600 kN-m/m³).

 - .9 ASTM D995, Standard Specification for Requirements Mixing Plants for Hot-Mixed, Hot-Laid Bituminous Paving Mixtures.
 - .10 ASTM D2419, Standard Test Method for Sand Equivalent Value of Soils and Fine Aggregate.
 - .11 ASTM D3203, Standard Test Method for Percent Air Voids in Compacted Dense and Open Bituminous Paving Mixtures.
 - .12 ASTM D4318, Standard Test Method for Liquid Limit, Plastic Limit and Plasticity Index of Soils.
 - .13 ASTM D4791, Standard Test Method for Flat Particles or Elongated Particles in Coarse Aggregate.

 - .4 Asphalt Institute (AI)
 - .1 Asphalt Institute MS-2-1993 Sixth Edition, Mix Design Methods for Asphalt Concrete.
- 1.4 SUBMITTALS
- .1 Submit asphalt concrete mix design to Owner's Representative for approval.
 - .2 Materials to be tested by testing laboratory approved by Owner's Representative.
 - .3 Submit test certificates showing suitability of materials at least 4 weeks prior to commencing work.

- .4 Inform Owner's Representative of proposed source of aggregates and provide access for sampling at least 4 weeks prior to commencing work.

PART 2 - PRODUCTS

2.1 MATERIALS

- .1 Granular base and sub-base material: to Section 31 05 16 – Aggregate Materials and following requirements:

- .1 Crushed or screened stone, gravel or sand.
 .2 Gradations: within limits specified when tested to ASTM C136 and ASTM C117. Sieve sizes to CAN/CGSB-8.1.
 .3 Table:

Sieve Designation	% Passing	
	Stone/Gravel	Gravel/Sand
200 mm	-	-
75 mm	-	100
50 mm	100	-
38.1 mm	70-100	-
25 mm	-	55-100
19 mm	50-75	-
12.5 mm	-	-
9.5 mm	40-65	-
4.75 mm	30-50	25-100
2.00 mm	-	15-80
0.425 mm	10-30	4-50
0.180 mm	-	-
	3-8	0-8

- .4 Granular base aggregates:

- .1 Crushed particles: at least 50 % of particles by mass retained on 4.75 mm sieve to have at least 1 freshly fractured face.
- .2 Asphalt concrete aggregates:
 - .1 Coarse aggregate is aggregate retained on 4.75 mm sieve and fine aggregate is aggregate passing 4.75 mm sieve when tested to ASTM C117.
 - .2 When dryer drum plant or plant without hot screening is used, process fine aggregate through 4.75 mm sieve and stockpile separately from coarse aggregate.
 - .3 Separate stock piles for coarse and fine aggregate are not required for sheet asphalt.
 - .4 Do not use aggregates having known polishing characteristics in mixes for surface courses.
 - .5 Aggregate: material to Section 31 05 16 – Aggregate Materials and following requirements:
 - .1 Crushed stone or gravel.
 - .2 Gradations to be within limits specified when tested to ASTM C136 and ASTM C117, Latest Edition. Sieve sizes to CAN/CGSB-8.1, Latest Edition.

Sieve Designation	% Passing
(Type 1 Base)	(Base Type 2)
19.0 mm	100
9.5 mm	60-80
4.75 mm	40-65
2.00 mm	30-50
0.180 mm	5-20
0.075 mm	3-8

- .3 Sand equivalent: to ASTM D2419, Minimum 50.
- .4 Magnesium Sulphate soundness: to ASTM C88. Max % loss by weight: coarse aggregate 12, fine aggregate 16.
- .5 Los Angeles Degradation: to ASTM C131, Max % loss by weight: coarse aggregate, 35.
- .6 Absorption: to ASTM C127, Max % by weight: coarse aggregate, 1.75.

- .7 Lightweight particles: to ASTM C123, Max % by mass, with less than 1.95. Relative density (formally Specific Gravity): 1.5.
- .8 Flat and elongated particles: to ASTM D4791, (with length to thickness ratio greater than 5); Max % by weight: coarse aggregate, 15.
- .9 Crushed particles: at least 60 % of particles by mass within each of following sieve designation ranges to have at least 1 freshly fractured face. Material to be divided into ranges using methods of ASTM C136.

Passing		Retained on
19 mm	to	9.5 mm
9.5 mm	to	4.75 mm

.10 Regardless of compliance with specified physical requirements, fine aggregates may be accepted or rejected on basis of past field performance.

- .3 Mineral filler for asphalt concrete:
 - .1 Finely ground particles of limestone, hydrated lime, Portland cement or other approved non-plastic mineral matter, thoroughly dry and free from lumps.
 - .2 Add mineral filler when necessary to meet job mix aggregate gradation or as directed by Owner's Representative to improve mix properties.
- .4 Asphalt cement: to CAN/CGSB-16.3, grade 120-150.
- .5 Asphalt prime: to CAN/CGSB-16.2, SS-1.
- .6 Sand blotter: clean granular material passing 4.75 mm sieve and free from organic matter or other deleterious materials.
- .7 Asphalt tack coat: to CAN/CGSB-16.2, grade SS-1.

2.2 MIX DESIGN

.1 Job mix formula to be approved by Owner's Representative.

.2 Design of mix: by Marshall Method to requirements below:

.1 Compaction blows on each face of test specimens: 50.

.2 Mix physical requirements:

Property	Asphalt / Concrete
Marshall Stability at 60°kN minimum	5.5
Flow Value, mm.	2-4
Air Voids in Mixture, %	3-5
Voids in Mineral Aggregate, % minimum	15
Index of Retained Stability, % minimum	75

.3 Measure physical requirements as follows:

.1 Marshall Load and flow value.

.2 Compute void properties on basis of bulk specific gravity of aggregate to ASTM C127, and ASTM C128. Make allowance for volume of asphalt absorbed into pores of aggregate.

.3 Air voids: to ASTM D3203.

.4 Voids in mineral aggregate: to Asphalt Institute, MS-2 chapter 4.

.5 Index of Retained Stability.

.4 Do not change job-mix without prior approval of Owner's Representative. When change in material source proposed, new job-mix formula to be approved by Owner's Representative.

.5 Return plant dust collected during processing to mix in quantities acceptable to Owner's Representative.

2.3 EQUIPMENT

.1 Pavers: mechanical grade controlled self-powered pavers capable of spreading mix within specified tolerances, true to line, grade and crown indicated.

.2 Rollers: sufficient number of rollers of type and weight to obtain specified density of compacted mix.

- .3 Vibratory rollers for parking lots and driveway:
 - .1 Minimum drum diameter: 750mm.
 - .2 Maximum amplitude of vibration (machine setting): 0.5mm for lifts less than 40mm thick.
- .4 Haul trucks: of sufficient number and of adequate size, speed and condition to ensure orderly and continuous operation and as follows:
 - .1 Boxes with tight metal bottoms.
 - .2 Covers of sufficient size and weight to completely cover and protect asphalt mix when truck fully loaded.
 - .3 In cool weather or for long hauls, insulate entire contact area of each truck box.
- .5 Suitable hand tools

PART 3 - EXECUTION

3.1 SUBGRADE SURFACE PREPARATION AND INSPECTION

- .1 Verify grades of subgrade drains and other items set in paving area for conformity with elevations and sections before placing granular base material.
- .2 Obtain approval of subgrade by Owner's Representative before placing granular base.

3.2 GRANULAR BASE AND GRANULAR SUBBASE

- .1 Place granular base and sub-base material on clean unfrozen surface, free from snow and ice.
- .2 Place granular base and sub-base to compacted thicknesses as indicated. Do not place frozen material.
- .3 Place in layers not exceeding 150 mm compacted thickness. Compact to density not less than 98 % maximum dry density in accordance with ASTM D698.
- .4 Finished base surface to be within 10 mm of specified grade, but not uniformly high or low.

3.3 ASPHALT PRIME

.1 Emulsified asphalt:

- .1 Dilute asphalt emulsion with clean water at 1:1 ratio for application. Mix thoroughly by pumping or other method approved by Owner's Representative.
- .2 Apply diluted asphalt emulsion at rate directed by Owner's Representative but do not exceed 5 L/m².
- .3 Apply on damp surface unless otherwise directed by Owner's Representative.

.2 Do not apply prime when air temperature is less than 5°C or when rain is forecast within 2 hours.

.3 If asphalt prime fails to set within 24 hours, spread sand blotter material in amounts required to absorb excess material. Sweep and remove excess blotter material.

3.4 PLANT AND MIXING REQUIREMENTS

.1 To ASTM D995.

3.5 ASPHALT CONCRETE PAVING

.1 Obtain approval of primer from Owner's Representative before placing asphalt mix.

.2 Place asphalt mix only when base or previous course is dry and air temperature is above 5°C.

.3 Place asphalt concrete in compacted layers not exceeding 50 mm.

.4 Minimum 135°C mix temperature required when spreading.

.5 Maximum 160°C mix temperature permitted at any time.

.6 Compact each course with roller as soon as it can support roller weight without undue cracking or displacement.

.7 Compact parking lot and driveway asphalt concrete to density not less than 95 % of density obtained with Marshall Specimens prepared in accordance with ASTM D1559, from samples of mix being used. Roll until roller marks are eliminated.

- .8 Keep roller speed slow enough to avoid mix displacement and do not stop roller on fresh pavement.
- .9 Moisten roller wheels with water to prevent pick up of material.
- .10 Compact mix with hot tampers or other equipment approved by Owner's Representative in areas inaccessible to roller.
- .11 Finish surface to be within 10 mm of design elevation and with no irregularities greater than 10 mm in 4.5 m.
- .12 Repair areas showing checking, rippling or segregation as directed by Owner's Representative.

3.6 JOINTS

- .1 Remove surplus material from surface of previously laid strip. Do not deposit on surface of freshly laid strip.
- .2 Paint contact surfaces of existing structures such as manholes, curbs or gutters with bituminous material prior to placing adjacent pavement.
- .3 For cold joints, cut back to full depth vertical face and tack face with hot asphalt.
- .4 For longitudinal joints, overlap previously laid strip with spreader by 25 to 50 mm.

3.7 TESTING

3.8 Inspection and testing of asphalt pavement will be carried out by designated testing laboratory. Refer to Sections 01 29 83 – Payment Procedures for Testing Laboratory Services and Section 01 45 00 - Quality Control.

- .1 Costs of tests will be paid under Section 01 21 00 – Allowances.

3.9 PROTECTION

- .1 Keep vehicular traffic off newly paved areas until paving surface temperature has cooled below 38°C. Do not permit stationary loads on pavement until 24 hours after placement.

- .2 Provide access to buildings as required. Arrange paving schedule so as not to interfere with normal use of premises.

END OF SECTION

PART 1 - GENERAL

1.1 RELATED SECTIONS

- .1 Section 31 23 10 - Excavating, Trenching and Backfilling.
- .2 Section 32 11 23 - Aggregate Base Course.
- .3 Section 32 12 18 - Asphalt Paving for Building Sites.
- .4 Section 03 10 00 - Concrete Forming and Accessories.
- .5 Section 03 20 00 - Concrete Reinforcing.
- .6 Section 03 30 00 - Cast-in-Place Concrete.

1.2 REFERENCES

- .1 Codes and standards referenced in this section refers to the latest edition t h e r e o f .
- .2 Canadian Standards Association (CSA).
 - .1 CAN/CSA-A23.1/A23.2, Concrete Materials and Methods of Concrete Construction/Methods of Test for Concrete.
- .3 Canadian General Standards Board (CGSB).
 - .1 CAN/CGSB-1.2, Boiled Linseed Oil.
 - .2 CAN/CGSB-3.3, Kerosene.
- .4 American Society for Testing and Materials (ASTM).
 - .1 ASTM D698, Test Method for Laboratory Compaction Characteristics of Soil Using Standard Effort (12,400ft-lbf/ft³) (600kN-m/m³).

1.3 TESTING

- .1 Testing of concrete to CAN3-A23.1 and requirements of Section 03 30 00 - Cast-in-Place Concrete.

1.4 ENVIRONMENTAL CONDITIONS

- .1 If temperature is below 5°C or if Engineer/Architect anticipates a temperature drop below this value within the next 24 hours, take all necessary measures to protect concrete from freezing.
- .2 Do not place concrete on frozen base.

PART 2 - PRODUCTS

2.1 MATERIALS

- .1 Concrete mixes and materials: to Section 03 30 00 - Cast-in-Place Concrete mix designed to produce a minimum compressive strength at 28 days of 32 MPa and containing 19mm maximum size, 6mm minimum size course aggregate, with water/cement ratio to CAN3-A23.1, for Class C-2 exposure.
- .2 Reinforcing steel: to Section 03 20 00 - Concrete Reinforcing
- .3 Joint filler to Section 03 30 00 – Cast-in-Place Concrete and to ASTM D1751-73 (1978), 20 mm performed, non-extruding, resilient bituminous type.
- .4 Granular base: to Section 32 11 23 - Aggregate Base Courses and to Section 31 23 10 - Excavating, Trenching and Backfilling.
- .5 Non-staining mineral type form release agent: chemically active release agents containing compounds that react with free lime to provide water soluble soap.
- .6 Fill material: to Section 31 23 10 - Excavating, Trenching and Backfilling.
- .7 Clear, polyethylene film to ASTM C171, minimum thickness 0.10 mm.

PART 3 - EXECUTION

3.1 GRADE PREPARATION

- .1 Do grade preparation work in accordance with Section 31 23 10 - Excavating, Trenching and Backfilling.
- .2 Construct embankments using excavated material free from organic matter or other objectionable materials. Dispose of surplus and unsuitable excavated material off site.
- .3 Place fill in maximum 150 mm layers and compact to at least 95% of maximum density to ASTM D698.
- .4 Ensure that Sub Grade, Granular Sub Base and Granular Base preparation has been inspected and approved by Engineer/Architect before commencing work.

3.2 GRANULAR SUB-BASE

- .1 Obtain Engineer's/Architect's approval of subgrade before placing granular sub- base.
- .2 Place granular base material to lines, widths, and depths as indicated.
- .3 Compact granular sub base to at least 100% of maximum dry density to ASTM D698.

3.3 FORMING

- .1 Form vertical surfaces to full depth using forming material that will not deform under loading by plastic concrete.
- .2 Securely position forms to required lines and grades.

.3 Coat forms with form release agent.

.4 Obtain approval of forms before placing concrete.

.5 Install metal fabrication as required.

3.4 CONCRETE

.1 Obtain Engineer's/Architect's approval of granular base and reinforcing steel prior to placing concrete.

.2 Do concrete work in accordance with Section 03 30 00 - Cast-in-Place Concrete.

.3 Finish exposed surface to a smooth, uniform finish, free of open texturing and exposed aggregate. Do not work more mortar to the surface that required. Do not use neat cement as a dryer to facilitate finishing.

.4 Wood float finish surface to provide no-skid texture.

.5 Immediately after floating, give sidewalk surface uniform finish to produce regular corrugations not exceeding 2 mm deep, by drawing broom in direction normal to centre line.

.6 Provide edging as indicated with 10 mm radius edging tool.

.7 Cure and protect concrete in accordance with CAN3-A23.1-M77.

3.5 TOLERANCES

.1 Finish surfaces to within 3mm in 3m as measured with 3m straightedge placed on surface.

3.6 EXPANSION AND CONTRACTION JOINTS

.1 Install tooled transverse contraction joints after floating, when concrete is stiff, but still plastic, at intervals of 1.5 m.

.2 Install expansion joints at intervals of 6 m.

.3 Install expansion joints around manholes and catch basins and along length adjacent to concrete curbs, catch basins, buildings, or permanent structure.

.4 When sidewalk is adjacent to curb, make joints of curb, gutters and sidewalk coincide.

.5 Install joint filler in expansion joints as indicated.

3.7 ISOLATION JOINTS

.1 Install isolation joints around manholes and catch basins and along length adjacent to concrete curbs, catch basins, buildings, or permanent structure.

.2 Install joint filler in isolation joints as indicated.

3.8 CURING

- .1 Cure concrete by adding moisture continuously in accordance with CAN/CSA-A23.1, to exposed finished surfaces for at least 1 day after placing.
- .2 Where polyethylene sheets are used for moist curing, place polyethylene over sufficiently hardened concrete to prevent drainage. Overlap adjacent edges 150 mm and tightly seal with sand or wood planks. Weigh sheets down to maintain close contact with concrete during the entire curing period.
- .3 Where burlap is used for moist curing, place two pre-wetted layers on concrete surface and keep continuously wet during curing period.

3.9 BACKFILL

- .1 Allow concrete to cure for 7 days prior to backfilling.
- .2 Backfill to designated elevations with material approved by Engineer/Architect. Compact and shape to required contours as indicated or as directed by Engineer/Architect.

END OF SECTION

PART 1 - GENERAL

1.1 RELATED DOCUMENTS

- .1 Drawings and general provisions of the Contract, including General and Supplementary Conditions and Division 01 Specification Sections, apply to this Section.

1.2 SUMMARY

- .1 Types of items described in this Section:
 - .1 Pavement-marking paint.
- .2 Types of items you will not find described in this Section:
 - .1 Asphalt paving.

1.3 SUBMITTALS

- .1 Product Data: For each type of product indicated. Include technical data and tested physical and performance properties.

1.4 QUALITY ASSURANCE

- .1 Preinstallation Conference: Conduct conference at Project site.
 - .1 Review marking layout, colours, and dimensions.
- .2 Equipment Requirements
 - .1 Paint applicator to be an approved pressure type mobile distributor capable of applying paint in single, double and dashed lines. Applicator to be capable of applying marking components uniformly, at rates specified, and to dimensions as indicated, and to have positive shut-off.

1.5 DELIVERY, STORAGE, AND HANDLING

- .1 Deliver pavement-marking materials to Project site in original packages with seals unbroken and bearing manufacturer's labels containing brand name and type of material, date of manufacture, and directions for storage.
- .2 Store pavement-marking materials in a clean, dry, protected location within temperature range required by manufacturer. Protect stored materials from direct sunlight.

1.6 PROJECT CONDITIONS

- .1 Pavement-Marking Paint: Proceed with pavement marking only on clean, dry surfaces and at a minimum ambient or surface temperature of 4.4 deg C for oil-based materials 12.8 deg C for water-based materials, and not exceeding 35 deg C.

PART 2 - PRODUCTS

2.1 PAINT

- .1 Paint: To CGSB1-GP-74M, alkyd traffic paint.
 - .1 Colour: to CGSB1-GP-12C,

- .1 General Markings: white 513-301.
- .2 Barrier Free Markings: blue, colour acceptable to authorities having jurisdiction.

- .2 Thinner: to CAN/CGSB-1.5.

PART 3 - EXECUTION

3.1 PREPARATION

- .1 Do not apply pavement-marking paint until layout, colours, and placement have been verified with Owner's Representative.
- .2 Allow paving to age for 30 days before starting pavement marking.
- .3 Pavement surface to be dry, free from ponded water, frost, ice, dust, oil, grease and other foreign materials. Sweep and clean surface to eliminate loose material and dust.

3.2 APPLICATION

- .1 Lay out pavement markings.
- .2 Apply paint with mechanical equipment to produce pavement markings, of dimensions indicated, with uniform, straight edges.
- .3 Apply at manufacturer's recommended rates to provide a minimum wet film thickness of 0.4 mm.
- .4 Unless otherwise approved by Owner's Representative, apply paint only when air temperature is above 10°C, wind speed is less than 60km/h and no rain is forecast within next 4h.
- .5 Do not thin paint unless approved by Owner's Representative.
- .6 Symbols and letters to conform to dimensions indicated. Where sizes are not given, then to sizes directed by the Owner's Representative.
- .7 Produce painted of uniform colour and density with sharp edges.
- .8 Thoroughly clean distributor tank before refilling with paint of different colour.

3.3 TOLERANCE

- .1 Paint markings to be within plus or minus 12mm of dimensions indicated.
- .2 Remove incorrect markings as directed by Owner's Representative.

3.4 PROTECTION OF COMPLETED WORK

- .1 Protect pavement markings until dry.

END OF SECTION

PART 1 - GENERAL

1.1 RELATED SECTIONS

- .1 Section 31 23 13 - Rough Grading.

1.2 QUALITY ASSURANCE

- .1 Test Reports: certified test reports showing compliance with specified performance characteristics and physical properties.
- .2 Certificates: product certificates signed by manufacturer certifying materials comply with specified performance characteristics and criteria and physical requirements.
- .3 Pre-Installation Meetings: conduct pre-installation meeting to verify project requirements, installation instructions and warranty requirements.

1.3 SOURCE QUALITY CONTROL

- .1 Advise Engineer/Architect of sources of topsoil to be utilized 7 days in advance of stating time.
- .2 Contractor is responsible for soil analysis and requirements for amendments to supply topsoil as specified.
- .3 Soil testing by recognized testing facility for PH, P and K, and organic matter.

PART 2 - PRODUCTS

2.1 TOPSOIL

- .1 Topsoil for seeded areas: mixture of mineral particulates, micro-organisms and organic matter which provides suitable medium for supporting intended plant growth.
 - .1 Soil texture based on The Canadian System of Soil Classification, to consist of 20% to 70% sand, minimum 7% clay, and contain 2 to 10 % organic matter by weight.
 - .2 Contain no toxic elements or growth inhibiting materials.
 - .3 Free from:
 - .1 Debris and stones over 50 mm diameter.
 - .2 Course vegetative material, 10 mm diameter and 100 mm length, occupying more than 2% of soil volume.
 - .4 Consistence: friable when moist.

2.2 SOIL AMENDMENTS

- .1 Fertilizer:
 - .1 Fertility: major soil nutrients present in following amounts:
 - .2 Nitrogen (N): 20 to 40 micrograms of available N per gram of topsoil.
 - .3 Phosphorus (P): 40 to 50 micrograms of phosphate per gram of topsoil.
 - .4 Potassium (K): 75 to 110 micrograms of potassium per gram of topsoil.

- .5 Calcium, magnesium, sulfur and micro-nutrients present in balanced ratios to support germination and/or establishment of intended vegetation.
- .6 pH value: 6.5 to 8.0.

- .2 Peatmoss:
 - .1 Derived from partially decomposed species of Sphagnum Mosses.
 - .2 Elastic and homogeneous, brown in colour.
 - .3 Free of wood and deleterious material which could prohibit growth.
 - .4 Shredded particle minimum size: 5 mm.

- .3 Sand: washed coarse silica sand, medium to coarse textured.

- .4 Limestone:
 - .1 Ground agricultural limestone.
 - .2 Gradation requirements: percentage passing by weight, 90% passing 1.0 mm sieve, 50% passing 0.125 mm sieve.

- .5 Fertilizer: industry accepted standard medium containing nitrogen, phosphorous, potassium and other micro-nutrients suitable to specific plant species or application or defined by soil test.

PART 3 - EXECUTION

3.1 STRIPPING OF TOPSOIL

- .1 Do not handle topsoil while in wet or frozen condition or in any manner in which soil structure is adversely affected.
- .2 Commence topsoil stripping of areas as indicated after area has been cleared of brush weeds and grasses and removed from site.
- .3 Strip topsoil to depths as indicated. Avoid mixing topsoil with subsoil where textural quality will be moved outside acceptable range of intended application.
- .4 Stockpile in locations as directed by Engineer/Architect. Stockpile height not to exceed 2 m.
- .5 Disposal of unused topsoil as directed by Engineer/Architect.
- .6 Protect stockpiles from contamination and compaction.

3.2 PREPARATION OF EXISTING GRADE

- .1 Verify that grades are correct. If discrepancies occur, notify Engineer/Architect and do not commence work until instructed by Engineer/Architect.
- .2 Grade soil, eliminating uneven areas and low spots, ensuring positive drainage.
- .3 Remove debris, roots, branches, stones in excess of 50 mm diameter and other deleterious materials. Remove soil contaminated with calcium chloride, toxic materials and petroleum products. Remove debris which protrudes more than 75 mm above surface. Dispose of removed material off site.

- .4 Course cultivate entire area which is to receive topsoil to minimum depth of 100 mm. Cross cultivate those areas where equipment used for hauling and spreading has compacted soil.

3.3 PLACING AND SPREADING OF TOPSOIL/PLANTING SOIL

- .1 Place topsoil after Engineer/Architect has accepted subgrade.
- .2 Spread topsoil in uniform layers not exceeding 150 mm, over unfrozen subgrade free of standing water.
- .3 For sodded areas keep topsoil 50/100 mm below finished grade.
- .4 Spread topsoil as indicated to following minimum depths after settlement and 80% compaction:
 - .1 150 mm for seeded areas.
 - .2 135 mm for sodded areas.
 - .3 300 mm for flower beds.
 - .4 500 mm for shrub beds.
- .5 Manually spread topsoil/planting soil around trees, shrubs and obstacles.

3.4 FINISH GRADING

- .1 Grade to eliminate rough spots and low areas and ensure positive drainage. Prepare loose friable bed by means of cultivation and subsequent raking.
- .2 Consolidate topsoil to required bulk density using equipment approved by Engineer/Architect. Leave surfaces smooth, uniform and firm against deep foot printing.

3.5 ACCEPTANCE

- .1 Engineer/Architect will inspect and test topsoil in place and determine acceptance of material, depth of topsoil and finish grading. Approval of topsoil material subject to soil testing and analysis.
- .2 Testing of topsoil will be carried out by testing laboratory designated by Engineer/Architect. Soil sampling, testing and analysis to be in accordance with Provincial regulations and standards. Engineer/Architect will pay for cost of tests as specified in Section 01 45 00 - Quality Control.

3.6 RESTORATION OF STOCKPILE SITES

- .1 Restore stockpile sites acceptable to Engineer/Architect.

3.7 SURPLUS MATERIAL

- .1 Dispose of materials not required where directed by Engineer/Architect.

END OF SECTION

PART 1 - GENERAL

1.1 RELATED WORK

- .1 Section 01 33 00 - Submittal Procedures.
- .2 Section 32 91 21 - Topsoil Placement and Grading.

1.2 SUBMITTALS

- .1 Submit samples in accordance with Section 01 33 00 - Submittal Procedures.
- .2 Submit:
 - .1 Sod for each type specified.
 - .1 Install approved samples in one square meter mock-ups and maintain in accordance with maintenance requirements during establishment period.
 - .2 Bio-degradable geotextile fabric.
- .3 Obtain approval of samples by Engineer/Architect.

1.3 QUALITY ASSURANCE

- .1 Test Reports: certified test reports showing compliance with specified performance characteristics and physical properties.
- .2 Certificates: product certificates signed by manufacturer certifying materials comply with specified performance characteristics and criteria and physical requirements.
- .3 Pre-Installation Meetings: conduct pre-installation meeting to verify project requirements, installation instructions and warranty requirements.

1.4 SCHEDULING

- .1 Schedule sod installation when frost has left ground and Before June 15 or between August 15 and September 30.
- .2 Schedule sod laying to coincide with preparation of soil surface.

PART 2 - PRODUCTS

2.1 MATERIALS

- .1 Number One Turf Grass Nursery Sod: sod that has been especially sown and cultivated in nursery fields as turf grass crop.
 - .1 Number one Named Cultivars: Nursery Sod grown from certified seed.
 - .2 Turf Grass Nursery Sod Quality:
 - .1 Not more than 2 broadleaf weeds on 10 other weds per 40 square meters.
 - .2 Density of sod sufficient so that no soil is visible from height of 1500 mm when mown to height of 50 mm.
 - .3 Mowing height limit: 35 to 65 mm.

- .4 Soil portion of sod: 6 to 15 mm in thickness.
 - .2 Commercial Grade Turf Grass Nursery: Sod that has not been grown as Turfgrass Nursery Sod crop.
 - .1 Mow sod at height directed by Engineer/Architect within 36 hours prior to lifting, and remove clippings.
 - .3 Sod establishment support:
 - .1 Geotextile fabric: biodegradable, 25 mm square mesh.
 - .2 Wooden pegs: 17 x 8 x 250 mm.
 - .4 Water:
 - .1 Supplied by Engineer/Architect at designated source.
 - .2 Potable, free of impurities.
 - .5 Fertilizer:
 - .1 To Canada "Fertilizers Act" and "Fertilizers Regulations".
 - .2 Complete, synthetic, slow release with 65% of nitrogen content in water• insoluble form.
- 2.2 SOURCE QUALITY CONTROL
- .1 Obtain approval from Engineer/Architect of sod at source.
 - .2 When proposed source of sod is approved, use no other source without written authorization.

PART 3 - EXECUTION

3.1 PREPARATION

- .1 Verify that grades are correct and prepared in accordance with Section 32 91 21 - Topsoil Placement and Grading. If discrepancies occur, notify Engineer/Architect.
- .2 Do not perform work under adverse field conditions such as frozen soil, excessively wet soil or soil covered with snow, ice, or standing water.
- .3 Fine grade surface free of humps and hollows to smooth, even grade, to contours and elevations indicated, to tolerance of plus or minus 8 mm, for Turfgrass Nursery Sod, and plus or minus 15 mm for commercial grade Turfgrass nursery, surface to drain naturally.
- .4 Remove and dispose of weeds; debris; stones 50 mm in diameter and larger; soil contaminated by oil, gasoline and other deleterious materials; off site in location as directed by Engineer/Architect.
- .5 Cultivate fine grade approved by Engineer/Architect to 25mm depth immediately prior to sodding.

3.2 SOD PLACEMENT

- .1 Lay sod within 24 hours of being lifted.
- .2 Lay sod sections in rows, longitudinally, along contours of slopes, joints staggered. Butt sections closely without overlapping or leaving gaps between sections. Cut out irregular or thin sections with sharp implements.

- .3 Roll sod as directed by Engineer/Architect. Provide close contact between sod and soil by light rolling. Use of heavy roller to correct irregularities in grade is not permitted.

3.3 SOD PLACEMENT ON SLOPES AND PEGGING

- .1 Install and secure geotextile fabric in areas indicated, in accordance with manufacturer's instructions.
- .2 Start laying sod at bottom of slopes.
- .3 Lay sod sections longitudinally, along contours of slopes as indicated.
- .4 Peg sod on slopes steeper than 3 horizontal to 1 vertical, within 1 m of catch basins and within 1 m of drainage channels and ditches to following pattern:
 - .1 100 mm below top edge at 200 mm on centre for first sod sections along contours of slopes.
 - .2 Not less than 9 pegs per square meter.
 - .3 Not less than 12 pegs per square meter in drainage structures. Adjust pattern as directed by Engineer/Architect.
 - .4 Drive pegs to 20 mm above soil surface of sod sections.

3.4 FERTILIZING PROGRAM

- .1 Fertilize during establishment and warranty periods to following program agreed to by Engineer/Architect.

3.5 MAINTENANCE DURING ESTABLISHMENT PERIOD

- .1 Perform following operations from time of installation until acceptance.
- .2 Water sodded areas in sufficient quantities and at frequency required to maintain optimum soil moisture condition to depth of 75 to 100 mm.
- .3 Cut grass to 50 mm when or prior to it reaching height of 75 mm. Remove clippings as directed by Engineer/Architect.
- .4 Maintain sodded areas weed free.
- .5 Fertilize areas in accordance with fertilizing program. Spread half of required amount of fertilizer in one direction and remainder at right angles and water in well.

3.6 ACCEPTANCE

- .1 Turf Grass Nursery Sod areas will be accepted by Engineer/Architect provided that:
 - .1 Sodded areas are properly established.
 - .2 Sod is free of bare and dead spots, and without weeds.
 - .3 No surface soil is visible from height of 1500 mm when grass has been cut to height of 50 mm.
 - .4 Sodded areas have been cut minimum 2 times, and within 24 h prior to acceptance.
 - .5 Fertilizing in accordance with fertilizer program has been carried out at least once.
- .2 Sodded Commercial Grade Turf Grass Nursery Sod areas will be accepted by Engineer/Architect provided that:

- .1 Sodded areas are properly established.
 - .2 Extent of surface soil visible when grass has been cut to height of 60 mm is acceptable.
 - .3 Sod is free of bare or dead spots and extent of weeds.
 - .4 Sodded areas have been cut minimum 2 times prior to acceptance.
 - .5 Fertilizing in accordance with fertilizer program has been carried out at least once.
- .3 Areas sodded in fall will be accepted in following spring one month after start of growing season provided acceptance conditions are fulfilled.

3.7 MAINTENANCE DURING WARRANTY PERIOD

- .1 Perform following operations from time of acceptance until end of warranty period:
 - .1 Water sodded Turf Grass Nursery Sod and Commercial Grade Turf Grass Nursery Sod areas at weekly intervals to obtain optimum soil moisture conditions to depth of 100 mm.
 - .2 Repair and re-sod dead or bare spots to satisfaction of Engineer/Architect.
 - .3 Cut grass and remove clippings as directed by Engineer/Architect.
 - .1 Turf Grass Nursery Sod:
 - .1 50 mm during normal growing conditions.
 - .2 Commercial Grade Turfgrass Nursery Sod :
 - .1 60 mm during normal growing conditions.
 - .3 Cut grass as directed by Engineer/Architect but at intervals so that approximately one third of growth is removed in single cut.
 - .4 Fertilize areas in accordance with fertilizing program. Spread half of required amount of fertilizer in one direction and remainder at right angles and water in well.
 - .5 Eliminate weeds by mechanical means to extent acceptable to Engineer/Architect.

3.8 CLEANING

- .1 Upon completion of installation, remove surplus materials, rubbish, tools and equipment barriers.

END OF SECTION

Memorial University of Newfoundland

CONCRETE AND ASPHALT REPAIRS 2024

GRD-508-23

ST. JOHN'S CAMPUS

MARCH 28, 2024

ISSUED FOR TENDER

LIST OF DRAWINGS

- C-1.0 - LOCATION PLAN
- C-1.1 - PARKING LOT 15 AND TOULINGUET CLOSE DEMOLITION AND NEW SITE PLANS
- C-1.2 - ARTS AND ADMIN AND PEDAGOGUES CLOSE AND IRWINS ROAD DEMOLITION AND NEW SITE PLANS
- C-1.3 - PARKING LOT 17 AND LIVYERS LOOP DEMOLITION AND NEW SITE PLANS
- C-1.4 - PATON COLLEGE TUNNEL DEMOLITION AND NEW SITE PLANS
- C-1.5 - MAIN DINING HALL DEMOLITION AND NEW SITE PLANS
- C-1.6 - ARCTIC AVE AND PARKING LOT 40 DEMOLITION AND NEW SITE PLANS
- C-1.7 - CORE SCIENCE FACILITY AND ARCTIC AVE AT CLINCH CRES. AND SANDPITS ROAD DEMOLITION AND NEW SITE PLANS
- C-1.8 - BOLLARD (WOODEN/METAL) LOCATIONS AND CATCH BASIN FRAME AND COVER LOCATION
- C-1.9 - WARNING SURFACE PLATE LOCATIONS AND SIGN POST LOCATIONS
- C-2.0 - SECTIONS AND DETAILS
- C-2.1 - SECTIONS AND DETAILS

GRD-508-23 ISSUED FOR TENDER

DEPARTMENT OF FACILITIES MANAGEMENT

This University was raised by the people of Newfoundland as a memorial to the fallen in the great wars, 1914-1918, 1939-1945, that in freedom of learning, their cause and sacrifice might not be forgotten.

- Dedication plaque, Arts & Administration Building, St. John's Campus



CONSTRUCTION NOTES (APPLIES TO ALL DRAWINGS)

1. ALL WORK TO BE PERFORMED TO IN ACCORDANCE WITH MEMORIAL UNIVERSITY OF NEWFOUNDLAND SPECIFICATIONS, AND CITY OF ST. JOHN'S CONSTRUCTION SPECIFICATIONS.
2. COORDINATE ALL DEMOLITION WITH OWNER'S REPRESENTATIVE PRIOR TO START OF CONSTRUCTION.
3. CONTRACTOR TO HAVE ALL UNDERGROUND SERVICES LOCATED PRIOR TO START OF CONSTRUCTION.
4. ALL EXISTING CONCRETE AND ASPHALT TO BE SAW CUT AT LIMITS OF CONSTRUCTION PRIOR TO DEMOLITION AND REINSTATEMENT.
5. EXCAVATE AS REQUIRED TO ACCOMMODATE CONSTRUCTION OF NEW CURB, GUTTER, SIDEWALK, ROADWAY, ETC. AS PER DETAILS.
6. ALL CONCRETE CURB, GUTTER, AND SIDEWALK TO BE CLASS C-2 EXPOSURE WITH MINIMUM COMPRESSIVE STRENGTH AT 28 DAYS OF 32 MPa.
7. ALL CONCRETE WALKWAYS TO BE A 150 mm IN THICKNESS.
8. INSTALL EXPANSION JOINTS ALONG LENGTH ADJACENT TO CONCRETE CURBS AND ADJACENT TO EXISTING CONCRETE WALKWAYS.
9. ALL MANHOLES TO BE SET 5 mm BELOW CONCRETE OR FINISHED ASPHALT GRADES.
10. ALL CATCH BASINS TO BE SET 30 mm BELOW FINISHED ASPHALT GRADES.
11. NEW LINE PAINTING TO BE COMPLETED AS SHOWN. REINSTATE ALL EXISTING LINE PAINTING AFFECTED BY CONSTRUCTION.
12. CONTRACTOR TO REPAIR ANY DAMAGE CAUSED BY CONSTRUCTION ACTIVITIES AT NO COST TO OWNER.
13. INSTALL EXPANSION JOINT AT INTERVALS OF 6 METERS IN NEW CONCRETE SIDEWALKS/WALKWAYS.
14. INSTALL CONCRETE SAW CUTS AT 2.1m MAX OR AS SHOWN ON DRAWINGS IN NEW CONCRETE SIDEWALKS/WALKWAYS.
15. REINSTATE LANDSCAPING ALONG EDGE OF NEW CONCRETE SIDEWALKS AND CURB. MIN 0.5m WIDTH.

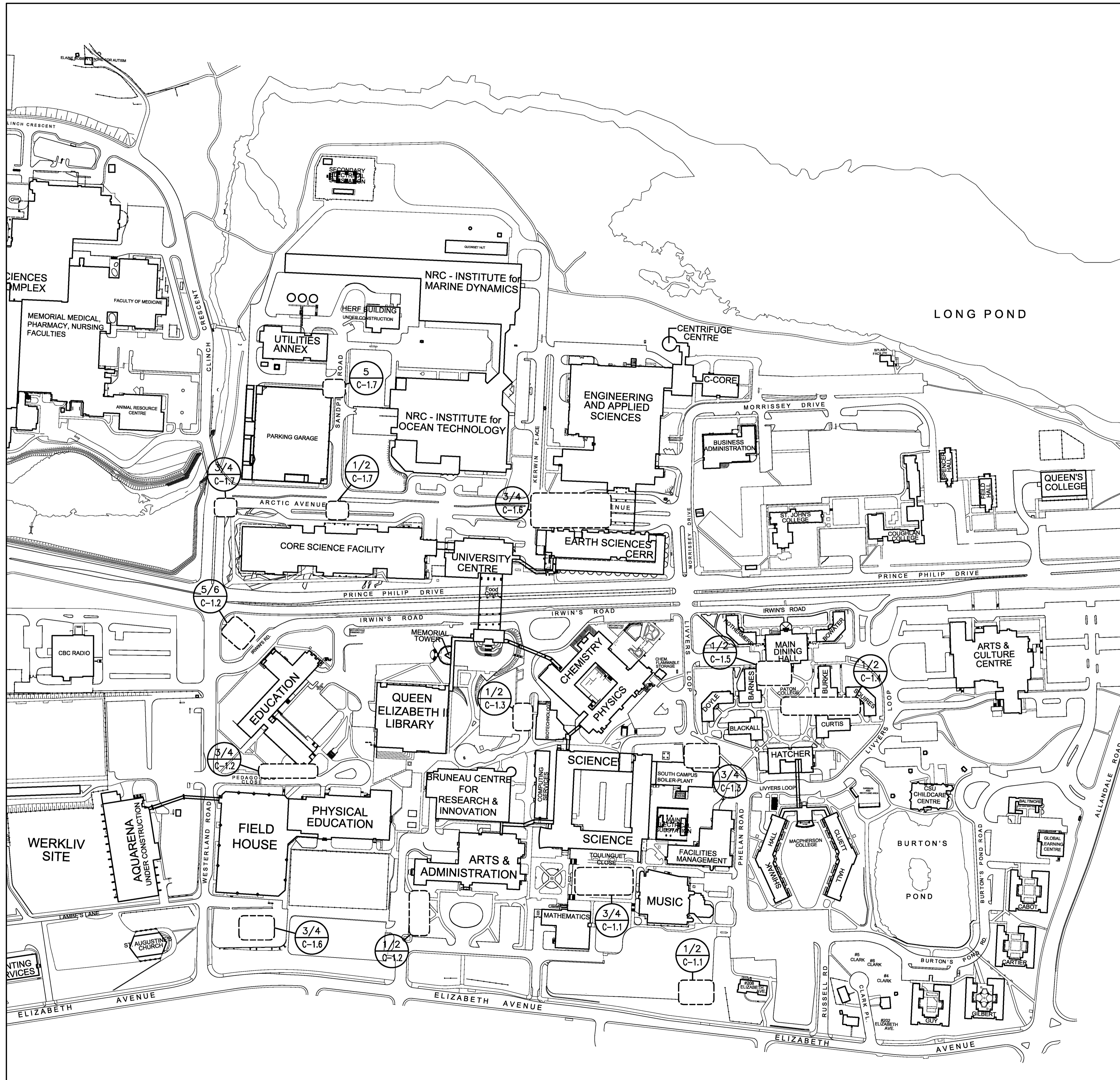

LOCATION PLAN
SCALE: N.T.S

1
C-1.0

No.	REVISION	DATE
R1	ISSUED FOR TENDER	MAR 28, 2024
R0	ISSUED FOR REVIEW	MAR 14, 2024

GENERAL NOTES

1. DO NOT SCALE FROM DRAWINGS.
2. ALL DIMENSIONS IN MILLIMETRES UNLESS OTHERWISE NOTED.
3. THE CONTRACTOR IS TO VERIFY ALL DIMENSIONS AND SITE CONDITIONS PRIOR TO SUBMISSION OF TENDERS.
4. ALL DEFICIENCIES FOUND IN THIS DRAWING IS TO BE BROUGHT TO THE ATTENTION OF THE FACILITIES ENGINEERING AND DEVELOPMENT OFFICE OF THE DEPARTMENT OF FACILITIES MANAGEMENT, MEMORIAL UNIVERSITY OF NEWFOUNDLAND, PRIOR TO THE SUBMISSION OF THE TENDERS.
5. PRICE B TO INCLUDE ALL SCOPE OUTLINED ON DRAWING C-1.5 ALL OTHER WORK TO BE INCLUDED UNDER PRICE A.

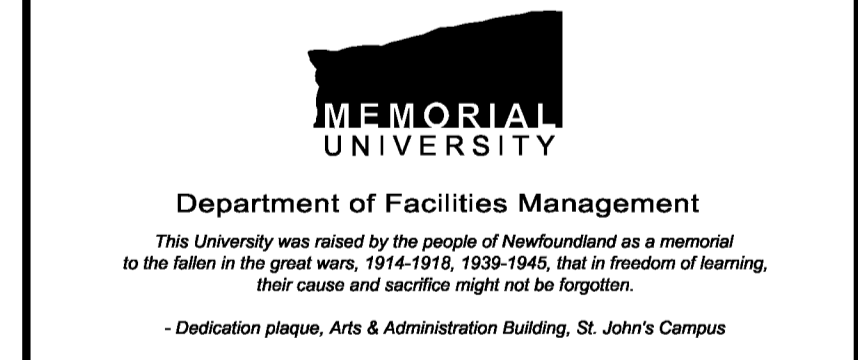
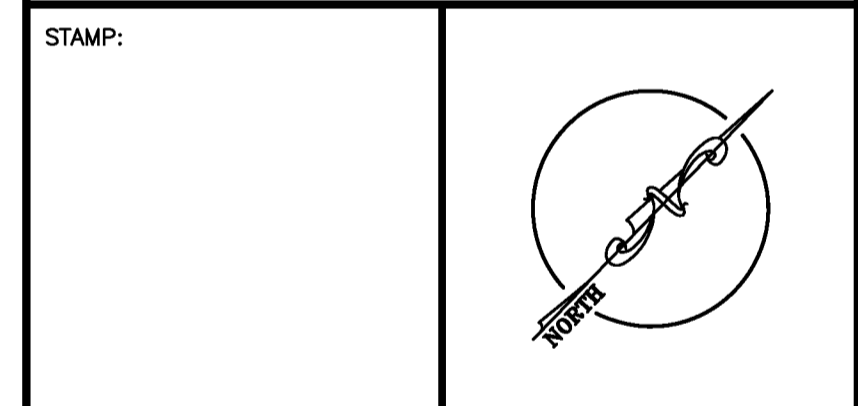

PROJECT NAME:
CONCRETE AND ASPHALT REPAIRS 2024
Project #: GRD-508-23

DRAWING TITLE:
LOCATION PLAN

DESIGNED: S.C/C.B	DRAWN: S.C
REVIEWED: H.H	APPROVED: H.H
SCALE: N.T.S	DATE: MAR 28 2024
MUN PROJECT No. GRD-508-23	DRAWING No. C-1.0

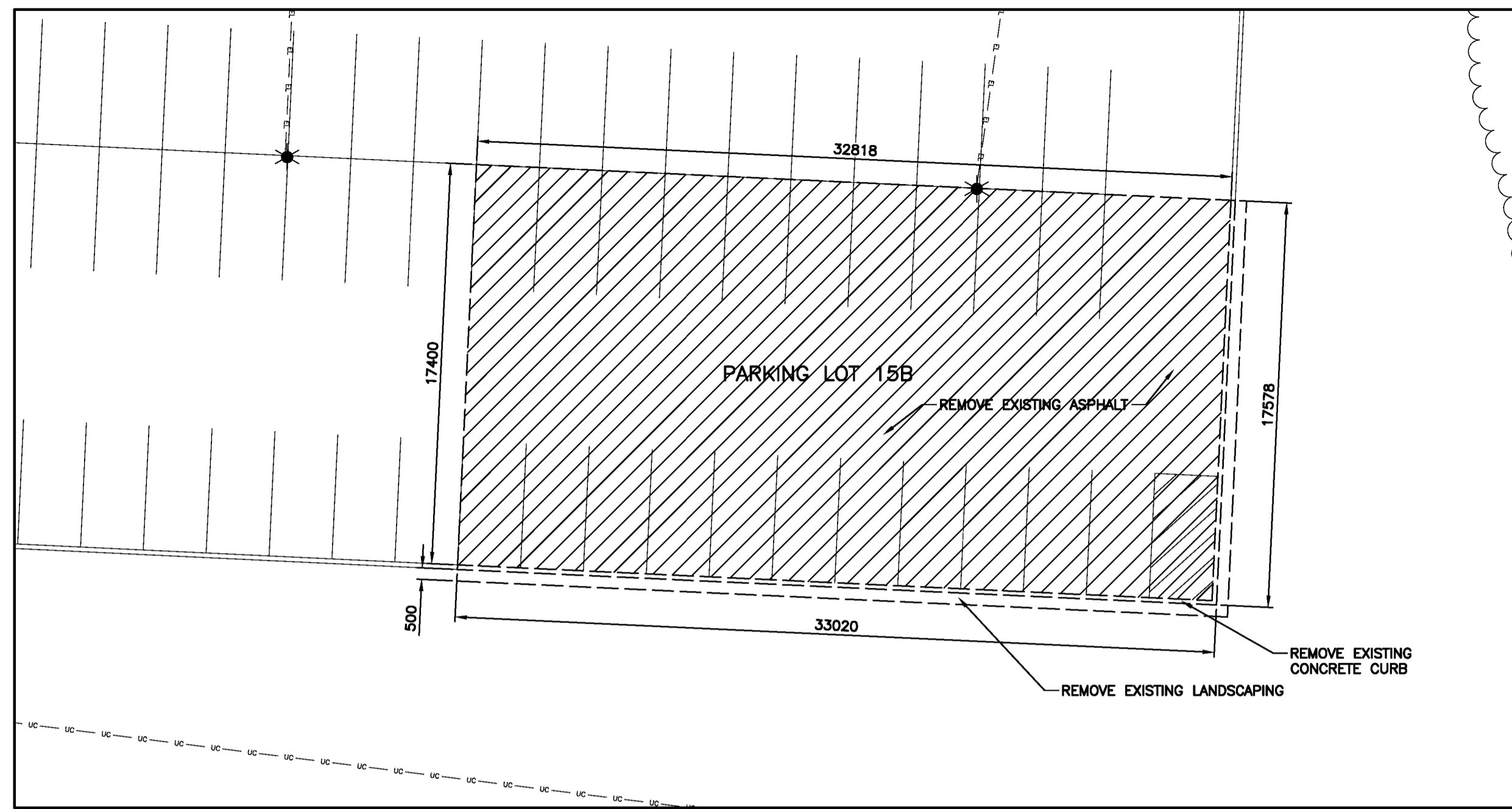

DEMOLITION SITE PLAN
SCALE: 1:200

1
C-1.1

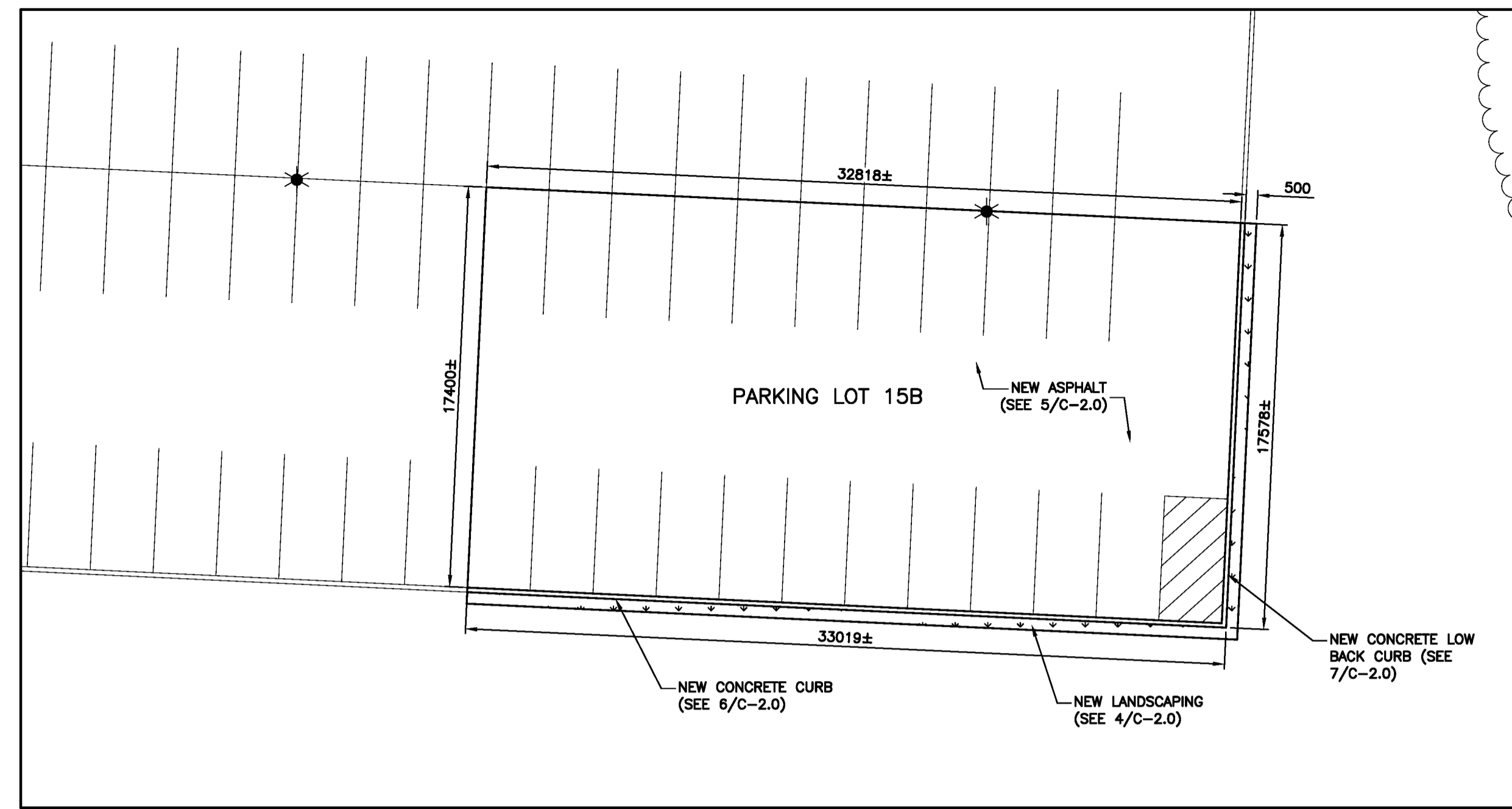

NEW SITE PLAN
SCALE: 1:200

2
C-1.1

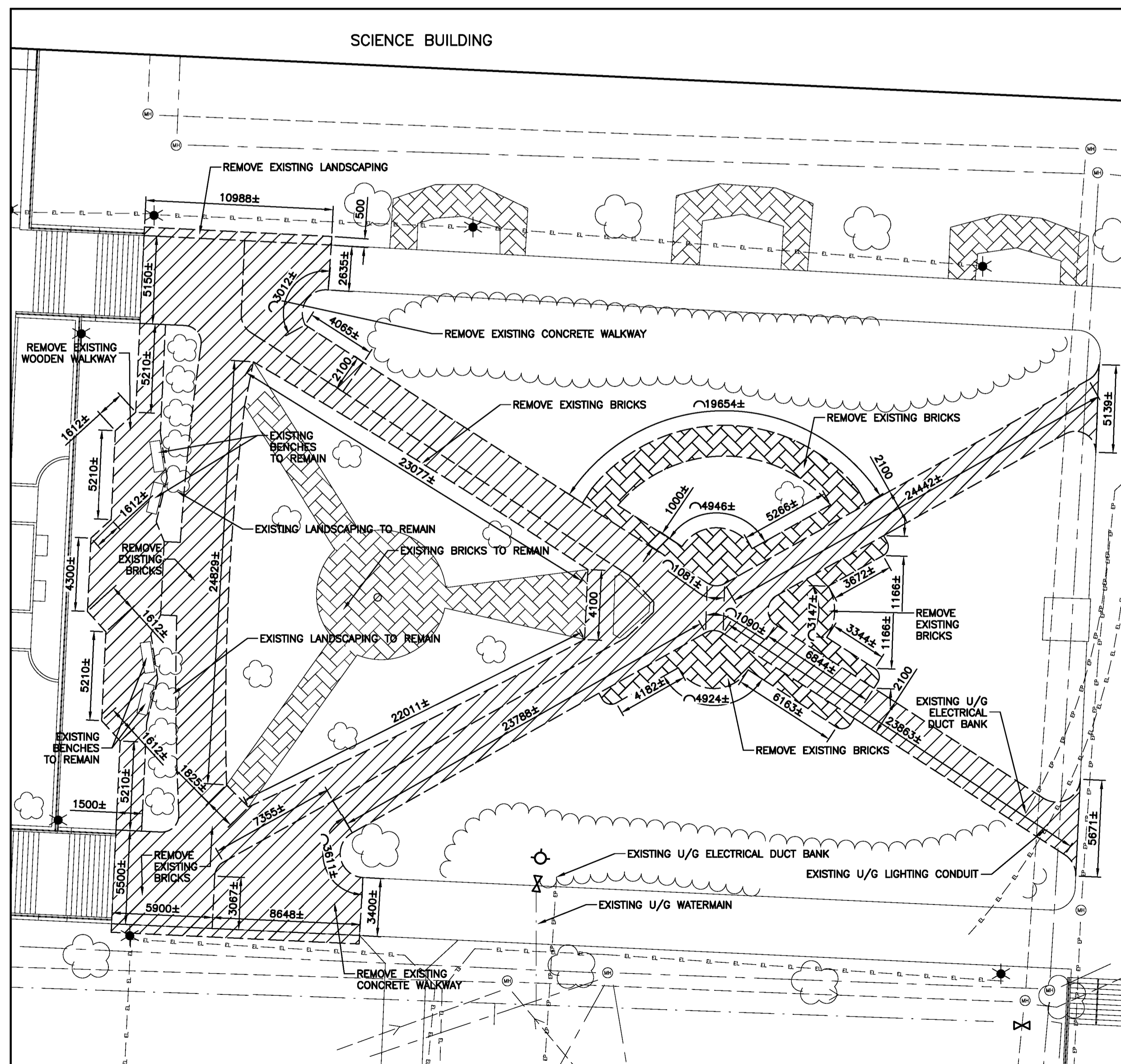

DEMOLITION SITE PLAN
SCALE: 1:200

3
C-1.1

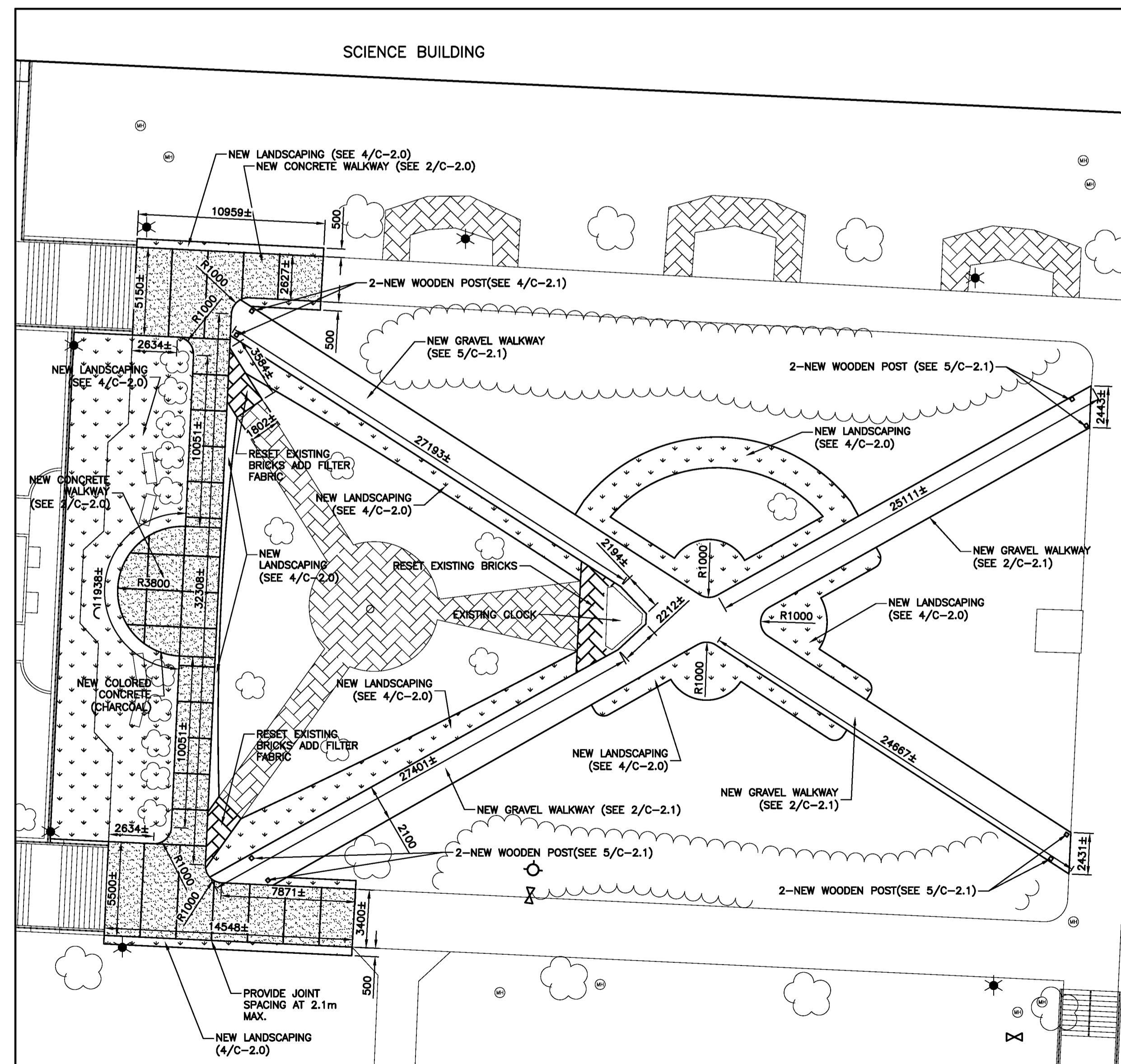

NEW SITE PLAN
SCALE: 1:200

4
C-1.1

No.	REVISION	DATE
R1	ISSUED FOR TENDER	MAR 28, 2024
R0	ISSUED FOR REVIEW	MAR 14, 2024

GENERAL NOTES

- DO NOT SCALE FROM DRAWINGS.
- ALL DIMENSIONS IN MILLIMETRES UNLESS OTHERWISE NOTED.
- THE CONTRACTOR IS TO VERIFY ALL DIMENSIONS AND SITE CONDITIONS PRIOR TO SUBMISSION OF TENDERS.
- ALL DEFICIENCIES FOUND IN THIS DRAWING IS TO BE BROUGHT TO THE ATTENTION OF THE FACILITIES ENGINEERING AND DEVELOPMENT OFFICE OF THE DEPARTMENT OF FACILITIES MANAGEMENT, MEMORIAL UNIVERSITY OF NEWFOUNDLAND, PRIOR TO THE SUBMISSION OF THE TENDERS.

LEGEND

- REMOVAL
- NEW LANDSCAPING
- NEW ASPHALT
- NEW CONCRETE
- NEW TOPSOIL
- WATER MAIN LINE
- SANITARY SEWER LINE
- STORM SEWER LINE
- UNDERGROUND ELECTRICAL CONDUIT
- UNDERGROUND HIGHVOLTAGE DUCT BANK
- GRADE DIRECTION
- LIGHT STANDARD
- MANHOLE
- VALVE
- CATCH BASIN
- FIRE HYDRANT
- TRANSFORMER

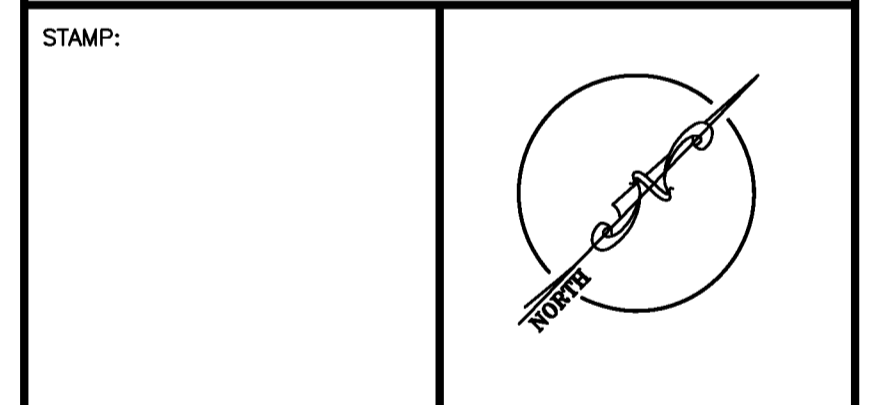

PROJECT NAME:
CONCRETE AND ASPHALT REPAIRS 2024
Project #: GRD-508-23

DRAWING TITLE:
PARKING LOT 15B AND TOULINGUET CLOSE DEMOLITION AND NEW SITE PLANS

DESIGNED: S.C/C.B	DRAWN: S.C
REVIEWED: H.H	APPROVED: H.H
SCALE: AS SHOWN	DATE: MAR 28 2024
MUN PROJECT No. GRD-508-23	DRAWING No. C-1.1

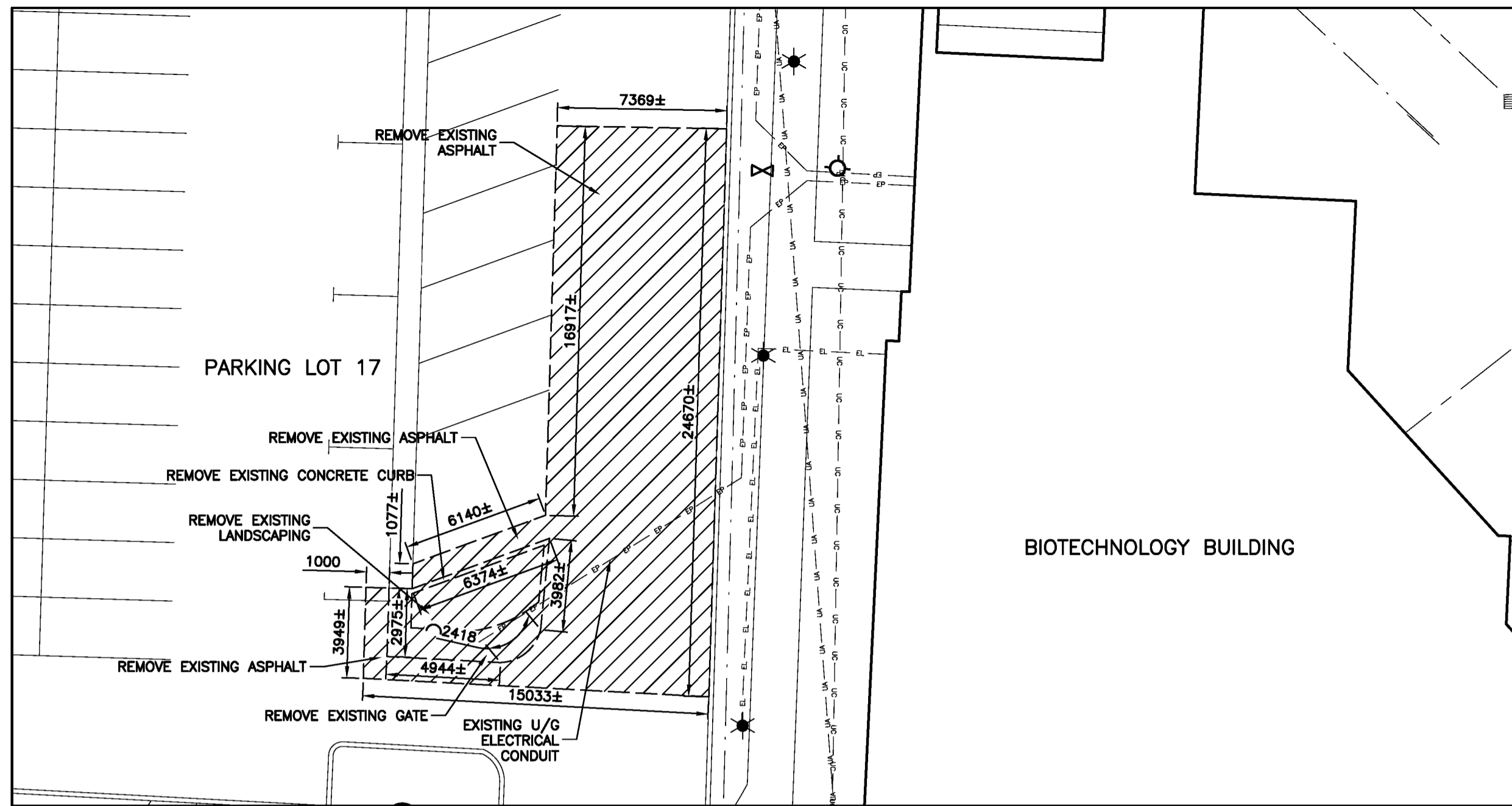

DEMOLITION SITE PLAN
SCALE: 1:200

1
C-1.3

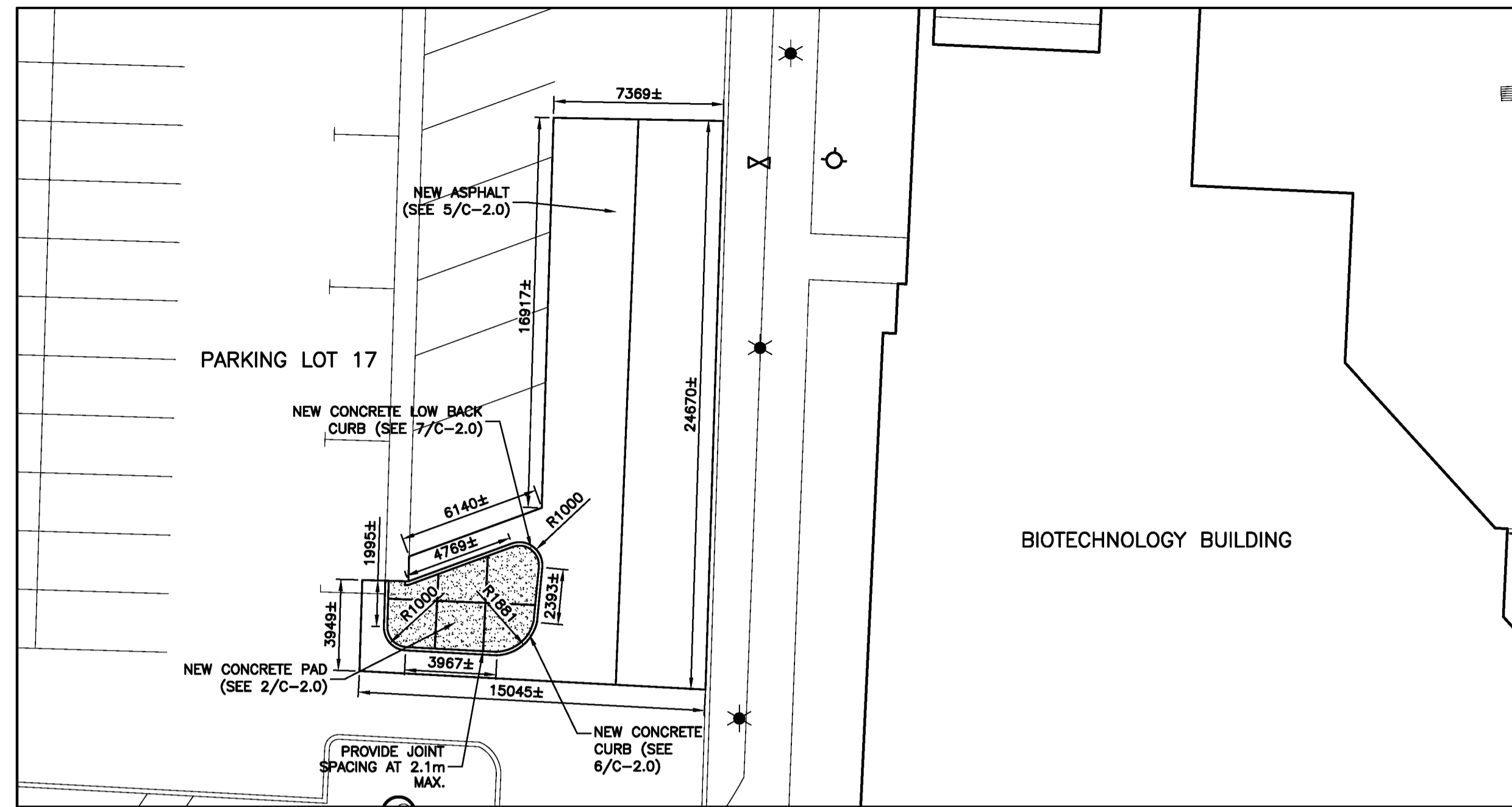

NEW SITE PLAN
SCALE: 1:200

2
C-1.3

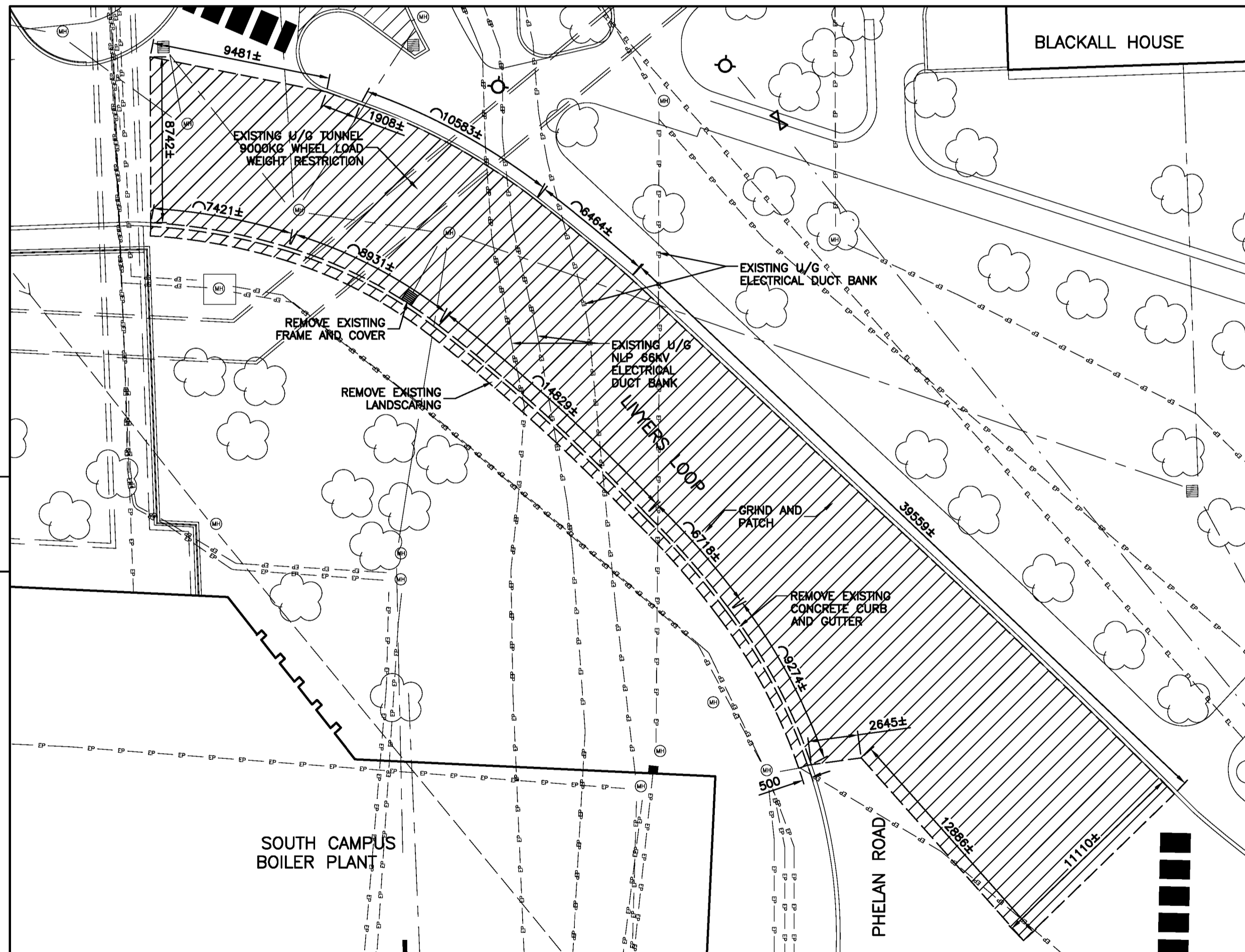

DEMOLITION SITE PLAN
SCALE: 1:200

3
C-1.3

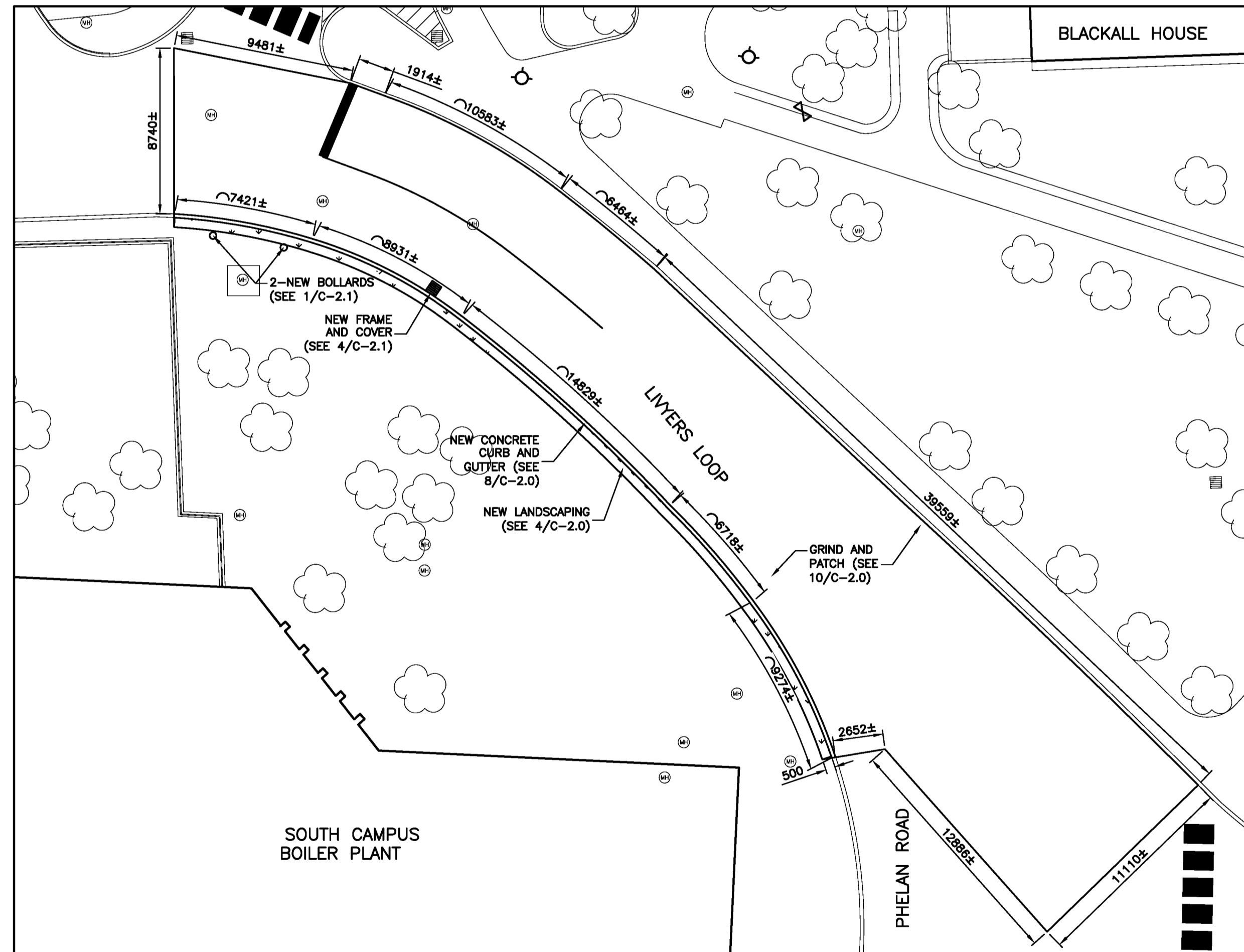

NEW SITE PLAN
SCALE: 1:200

4
C-1.3

No.	REVISION	DATE
R1	ISSUED FOR TENDER	MAR 28, 2024
R0	ISSUED FOR REVIEW	MAR 14, 2024

GENERAL NOTES

- DO NOT SCALE FROM DRAWINGS.
- ALL DIMENSIONS IN MILLIMETRES UNLESS OTHERWISE NOTED.
- THE CONTRACTOR IS TO VERIFY ALL DIMENSIONS AND SITE CONDITIONS PRIOR TO SUBMISSION OF TENDERS.
- ALL DEFICIENCIES FOUND IN THIS DRAWING IS TO BE BROUGHT TO THE ATTENTION OF THE FACILITIES ENGINEERING AND DEVELOPMENT OFFICE OF THE DEPARTMENT OF FACILITIES MANAGEMENT, MEMORIAL UNIVERSITY OF NEWFOUNDLAND, PRIOR TO THE SUBMISSION OF THE TENDERS.

LEGEND

- REMOVAL
- NEW LANDSCAPING
- NEW ASPHALT
- NEW CONCRETE
- NEW TOPSOIL
- WATER MAIN LINE
- SANITARY SEWER LINE
- STORM SEWER LINE
- UNDERGROUND ELECTRICAL CONDUIT
- UNDERGROUND HIGH-VOLTAGE DUCT BANK
- GRADE DIRECTION
- LIGHT STANDARD
- MANHOLE
- VALVE
- CATCH BASIN
- FIRE HYDRANT
- TRANSFORMER

STAMP:

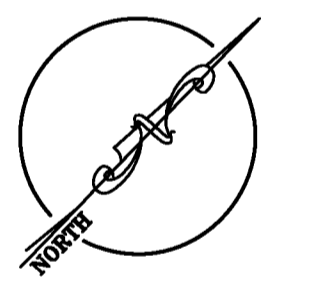

Department of Facilities Management
This University was raised by the people of Newfoundland as a memorial to the fallen in the great wars, 1914-1918, 1939-1945, that in freedom of learning, their cause and sacrifice might not be forgotten.
-Dedication plaque, Arts & Administration Building, St. John's Campus

PROJECT NAME:

CONCRETE AND ASPHALT REPAIRS 2024

Project #: GRD-508-23

DRAWING TITLE:

PARKING LOT 17 AND LIVYERS LOOP DEMOLITION AND NEW SITE PLANS

DESIGNED: S.C/C.B	DRAWN: S.C
REVIEWED: H.H	APPROVED: H.H
SCALE: AS SHOWN	DATE: MAR 28 2024
MUN PROJECT No. GRD-508-23	DRAWING No. C-1.3

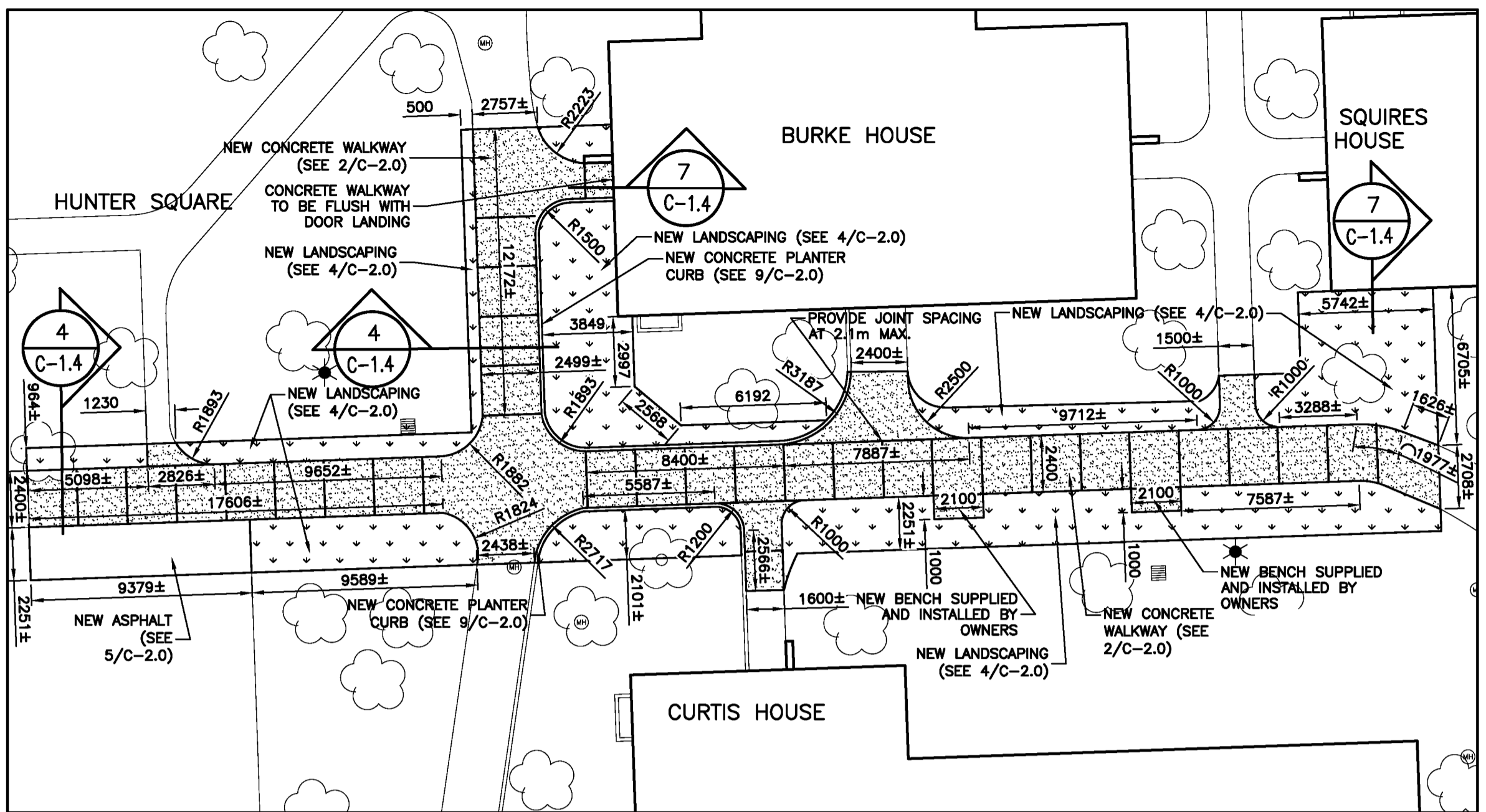
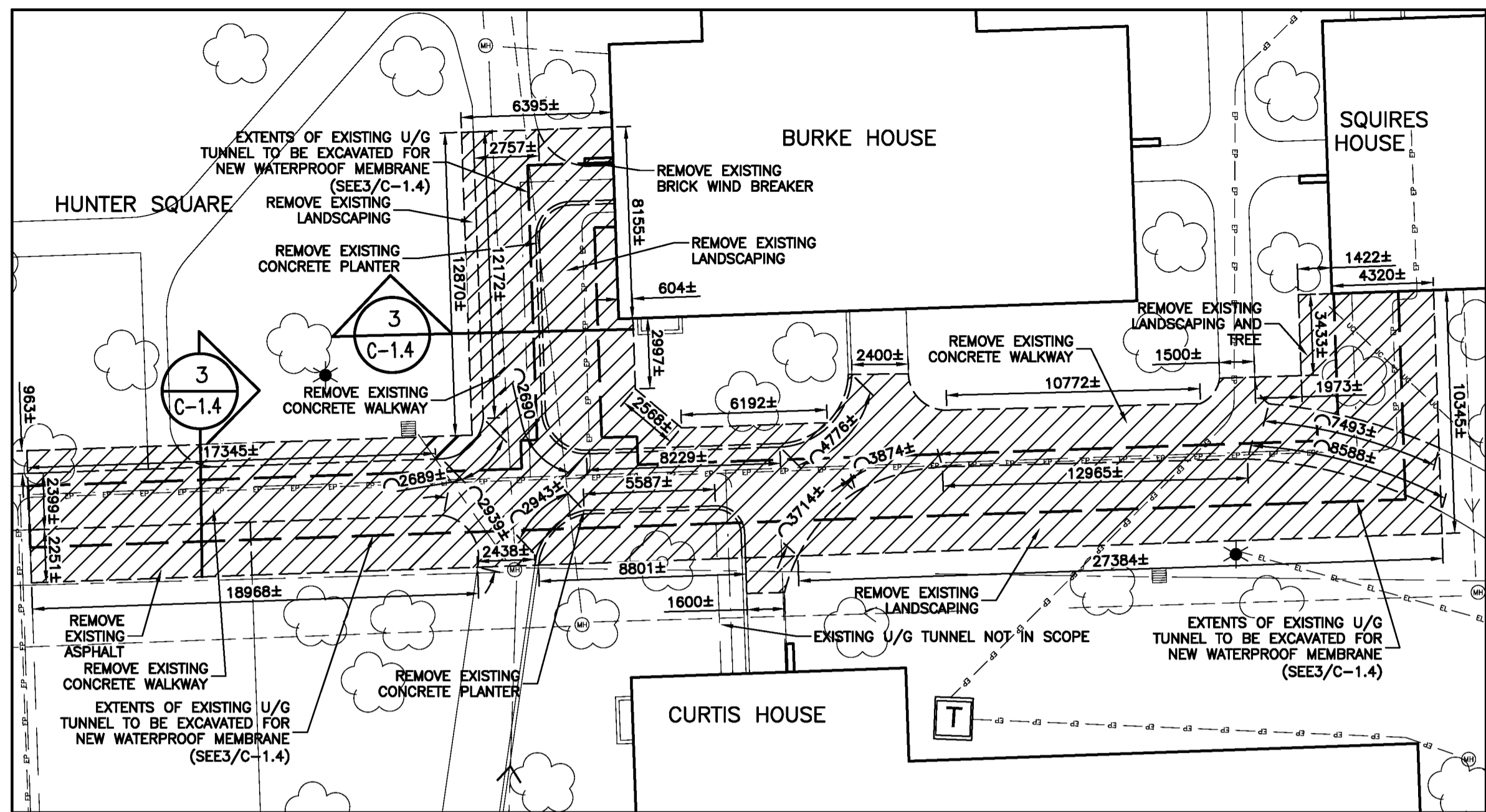

DEMOLITION SITE PLAN
SCALE: 1:200

NEW SITE PLAN
SCALE: 1:200

No.	REVISION	DATE
R1	ISSUED FOR TENDER	MAR 28, 2024
R0	ISSUED FOR REVIEW	MAR 14, 2024

GENERAL NOTES

- DO NOT SCALE FROM DRAWINGS.
- ALL DIMENSIONS IN MILLIMETRES UNLESS OTHERWISE NOTED.
- THE CONTRACTOR IS TO VERIFY ALL DIMENSIONS AND SITE CONDITIONS PRIOR TO SUBMISSION OF TENDERS.
- ALL DEFICIENCIES FOUND IN THIS DRAWING IS TO BE BROUGHT TO THE ATTENTION OF THE FACILITIES ENGINEERING AND DEVELOPMENT OFFICE OF THE DEPARTMENT OF FACILITIES MANAGEMENT, MEMORIAL UNIVERSITY OF NEWFOUNDLAND, PRIOR TO THE SUBMISSION OF THE TENDERS.
- TUNNEL RE-WATERPROOFING TO BE COMPLETED BY CERTIFIED ROOFING SUBCONTRACTOR. SEE SPECIFICATIONS.

LEGEND

	REMOVE
	NEW LANDSCAPING
	NEW ASPHALT
	NEW CONCRETE
	NEW TOPSOIL
	WATER MAIN LINE
	SANITARY SEWER LINE
	STORM SEWER LINE
	UNDERGROUND ELECTRICAL CONDUIT
	UNDERGROUND HIGHVOLTAGE DUCT BANK
	GRADE DIRECTION
	LIGHT STANDARD
	MANHOLE
	VALVE
	CATCH BASIN
	FIRE HYDRANT
	TRANSFORMER

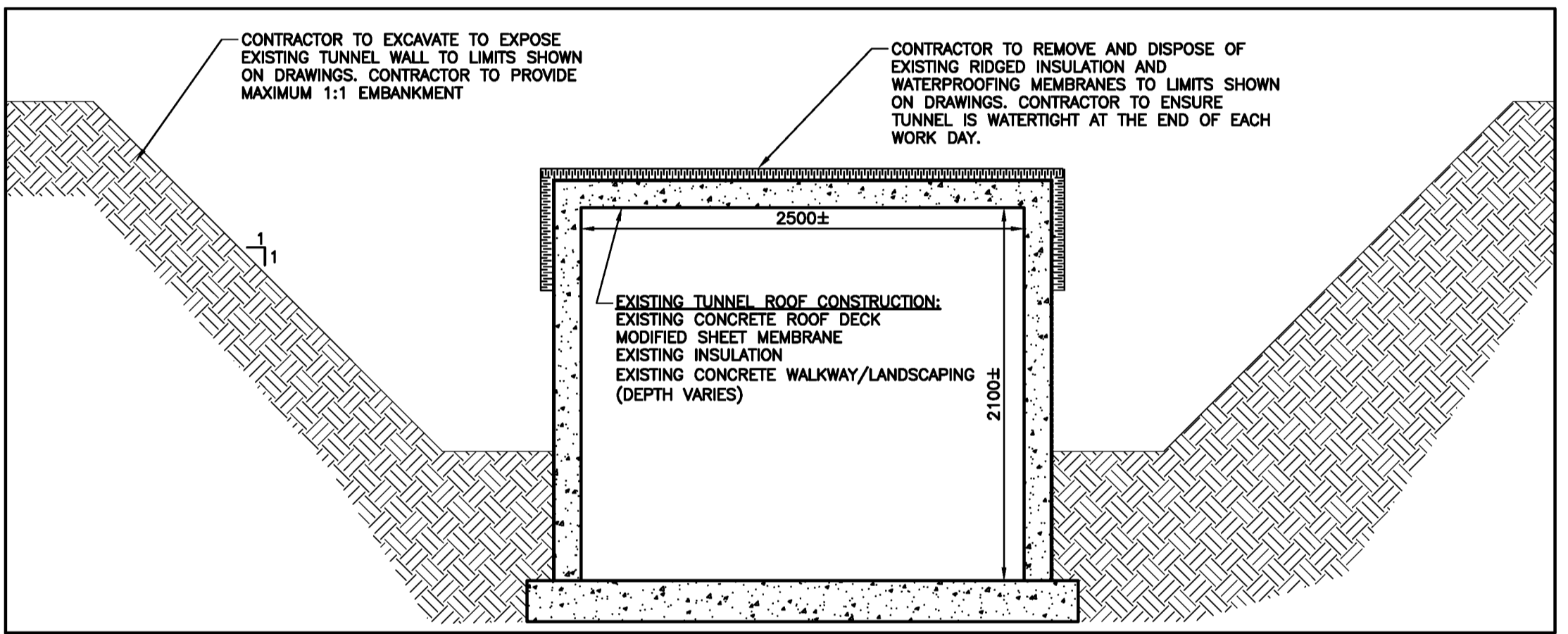

DEMOLITION TUNNEL SECTION
SCALE: 1:30

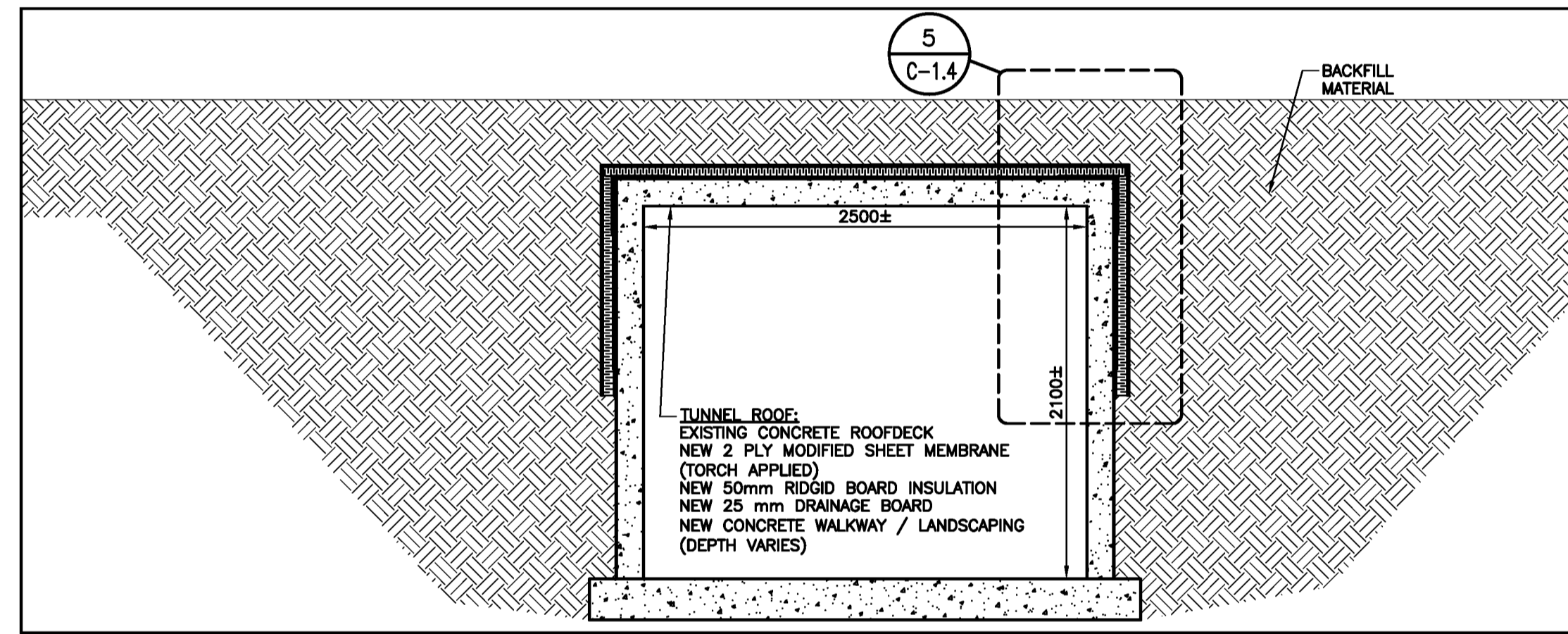

NEW TUNNEL SECTION
SCALE: 1:30

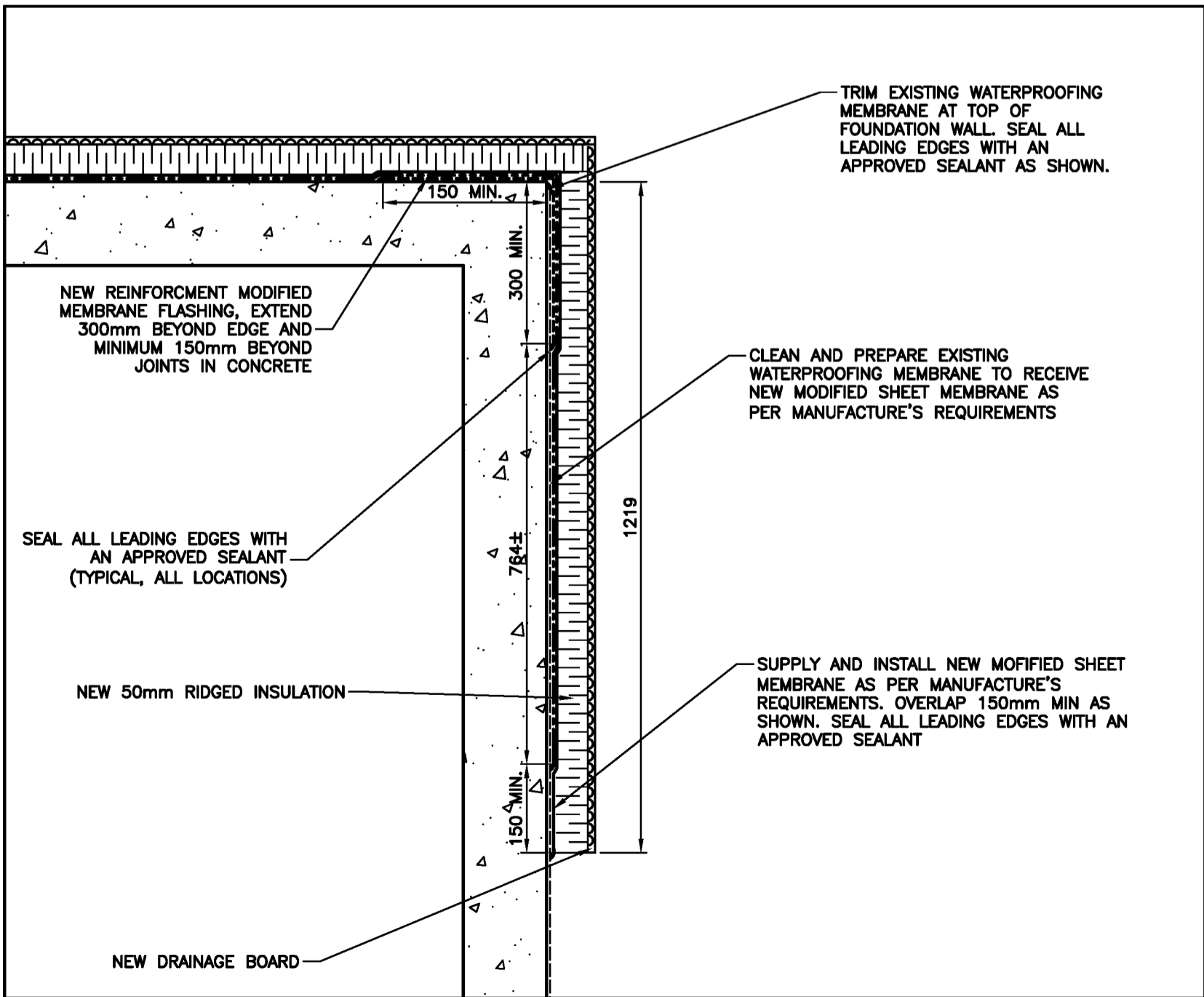

NEW WATERPROOFING MEMBRANE: TYPICAL ROOF/WALL DETAIL
SCALE: 1:10

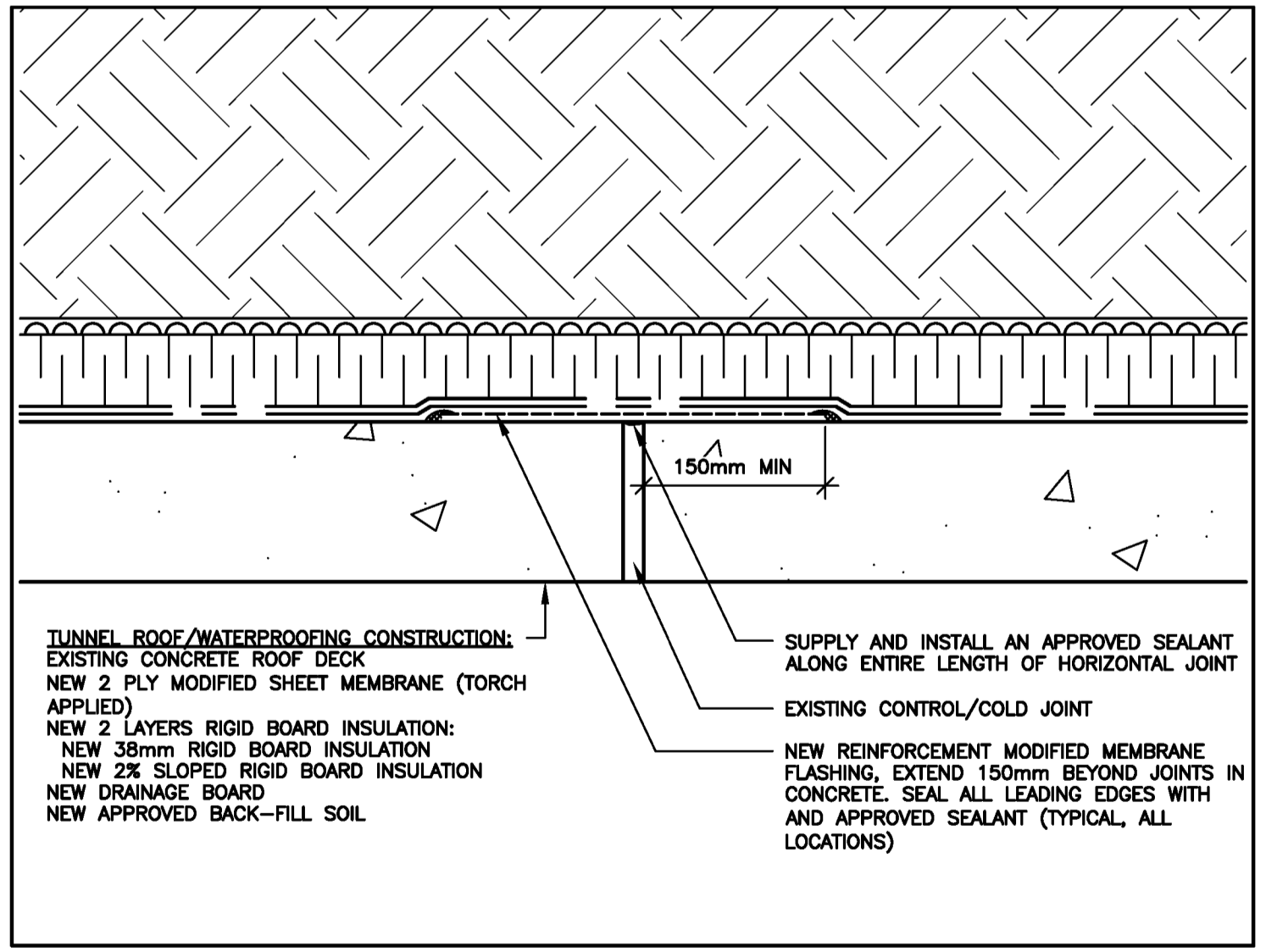

CONTROL/COLD JOINT DETAIL
SCALE: 1:5

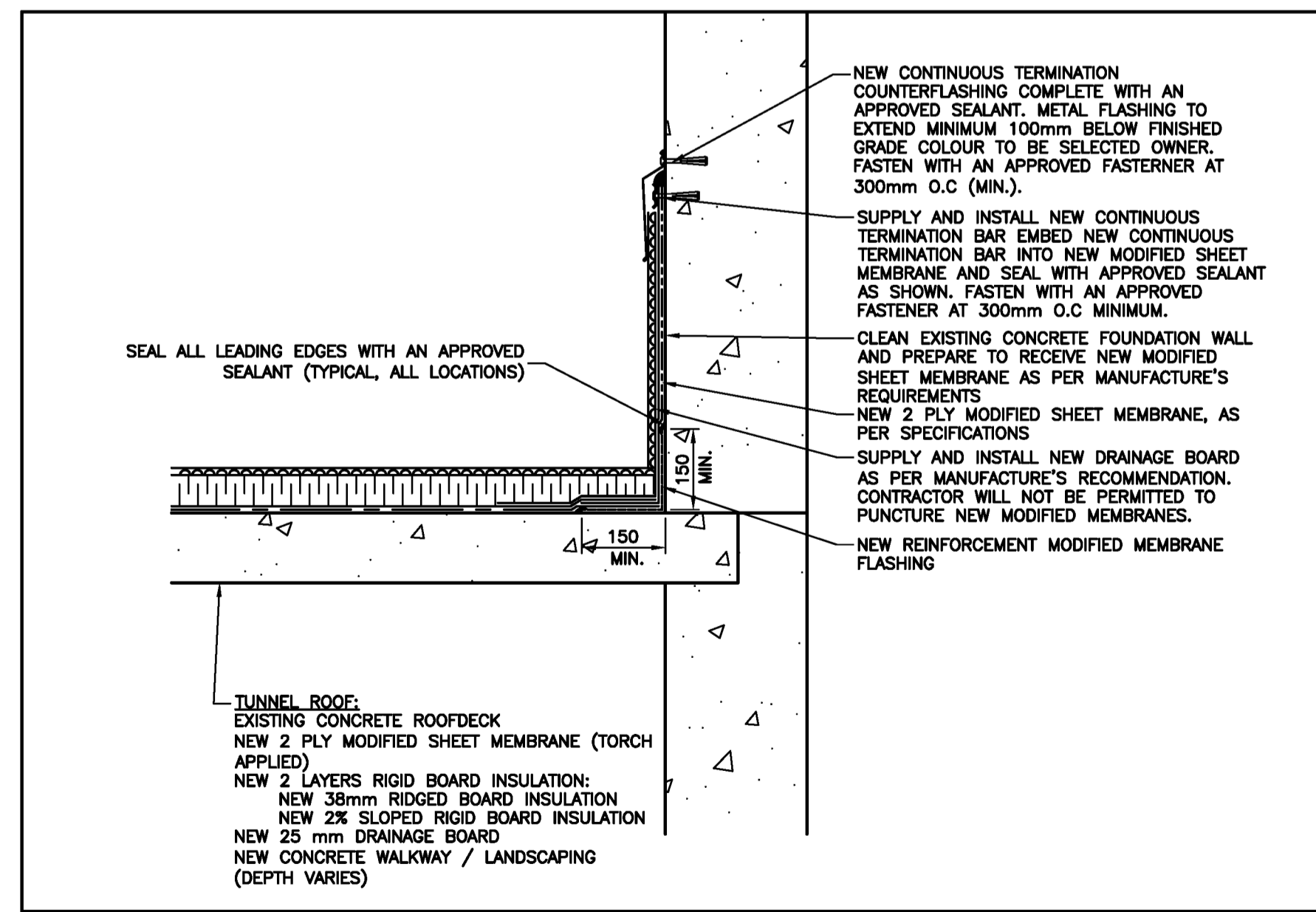

NEW WATERPROOFING MEMBRANE: TYPICAL ROOF/WALL DETAIL
SCALE: 1:10

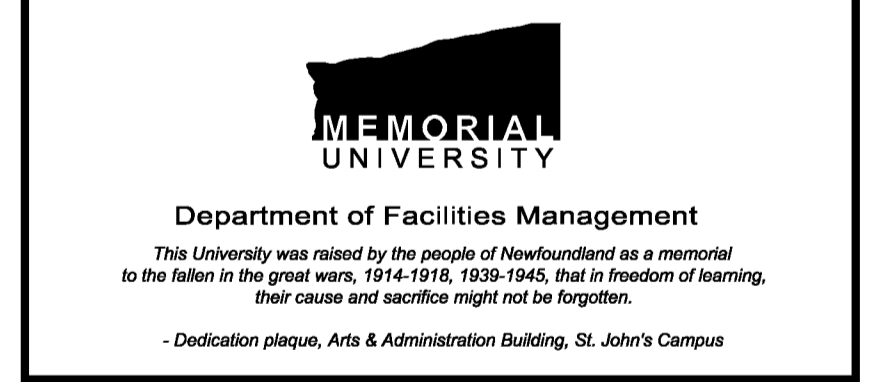
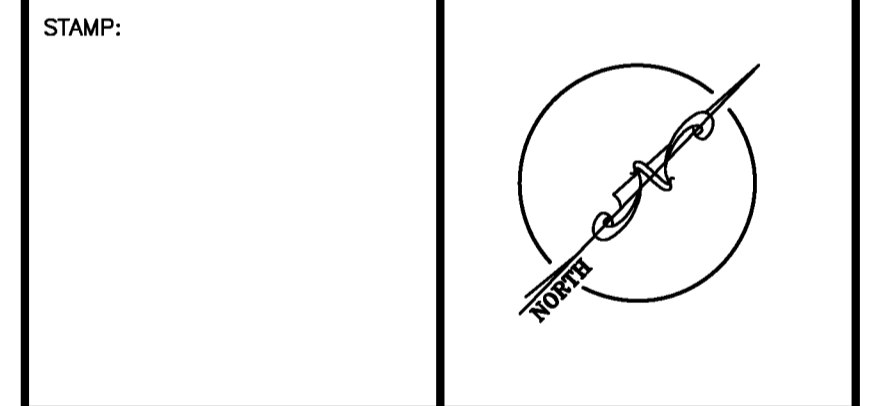

PROJECT NAME:
CONCRETE AND ASPHALT REPAIRS 2024
Project #: GRD-508-23

DRAWING TITLE:
PATON COLLEGE TUNNEL DEMOLITION AND NEW SITE PLANS

DESIGNED: S.C/C.B	DRAWN: S.C
REVIEWED: H.H	APPROVED: H.H
SCALE: AS SHOWN	DATE: MAR 28 2024
MUN PROJECT No. GRD-508-23	DRAWING No. C-1.4

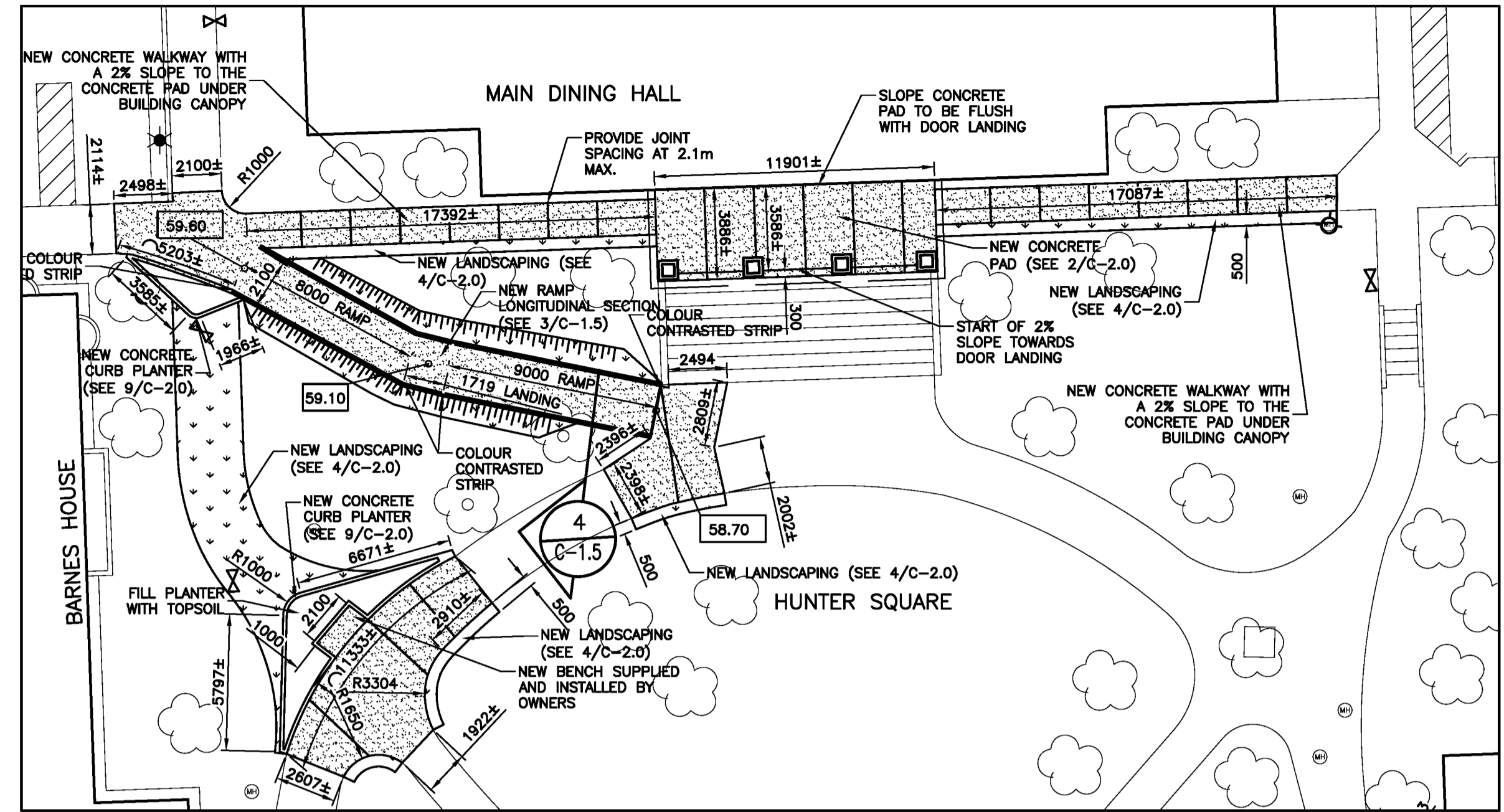
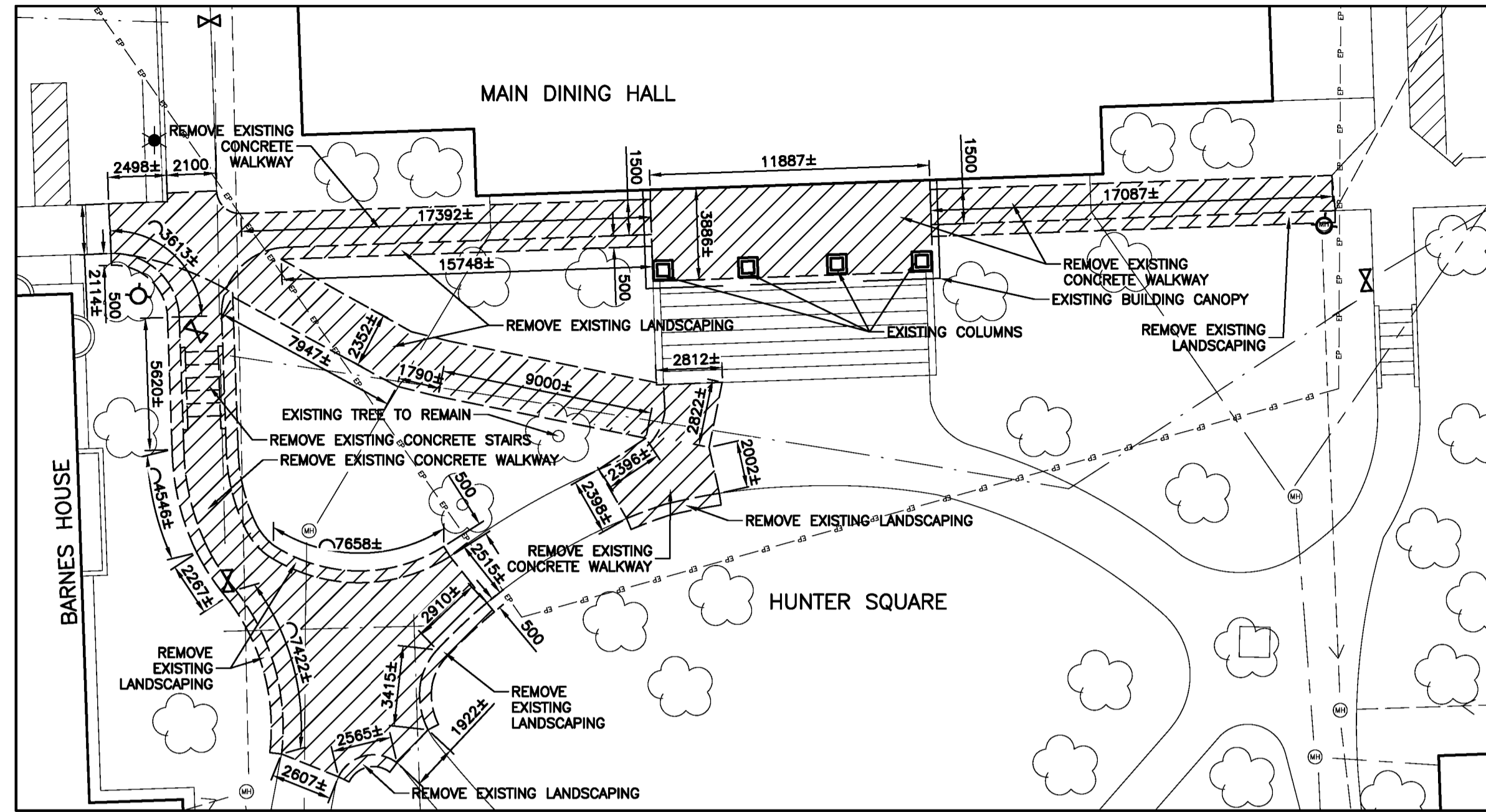

DEMOLITION SITE PLAN
SCALE: 1:200

1
C-1.5

DEMOLITION SITE PLAN
SCALE: 1:200

2
C-1.5

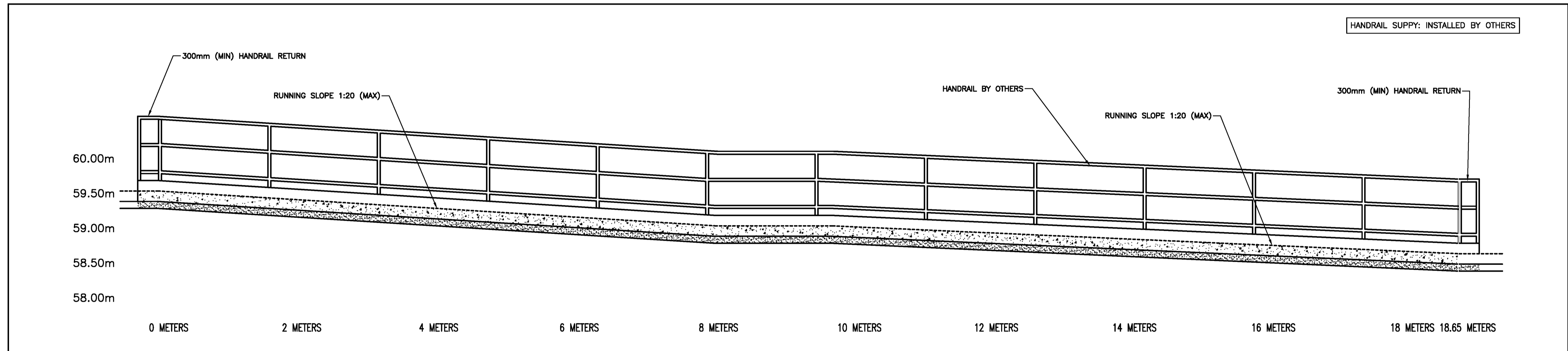

NEW ELEVATION - RAMP
SCALE: 1:35

3
C-1.5

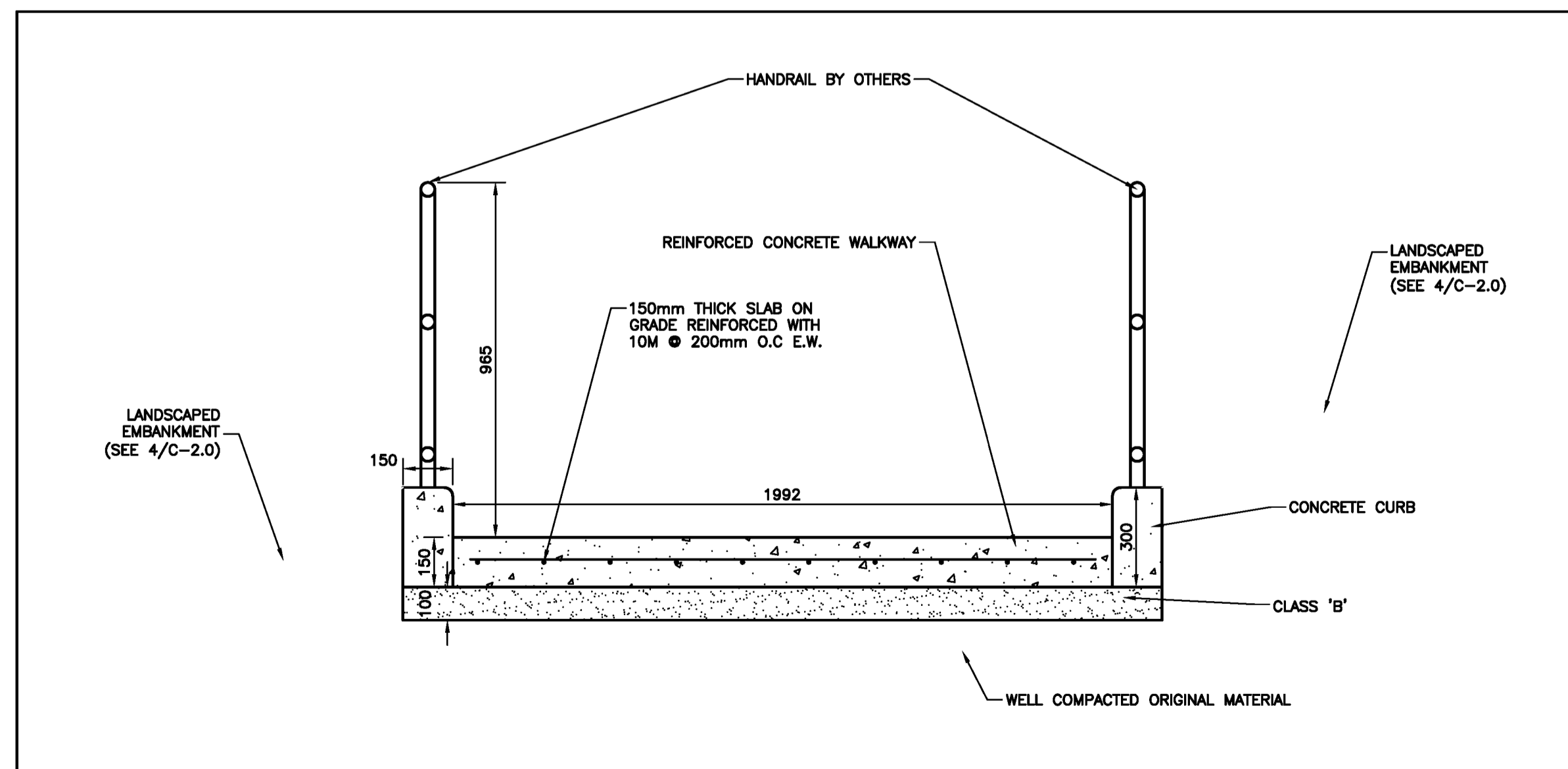

NEW RAMP SECTION
SCALE: 1:15

4
C-1.5

No.	REVISION	DATE
R1	ISSUED FOR TENDER	MAR 28, 2024
R0	ISSUED FOR REVIEW	MAR 14, 2024

GENERAL NOTES

- DO NOT SCALE FROM DRAWINGS.
- ALL DIMENSIONS IN MILLIMETRES UNLESS OTHERWISE NOTED.
- THE CONTRACTOR IS TO VERIFY ALL DIMENSIONS AND SITE CONDITIONS PRIOR TO SUBMISSION OF TENDERS.
- ALL DEFICIENCIES FOUND IN THIS DRAWING IS TO BE BROUGHT TO THE ATTENTION OF THE FACILITIES ENGINEERING AND DEVELOPMENT OFFICE OF THE DEPARTMENT OF FACILITIES MANAGEMENT, MEMORIAL UNIVERSITY OF NEWFOUNDLAND, PRIOR TO THE SUBMISSION OF THE TENDERS.
- PRICE B TO INCLUDE ALL SCOPE OUTLINED ON DRAWING C-1.5. ALL OTHER WORK TO BE INCLUDED UNDER PRICE A.

LEGEND

- REMOVAL
- NEW LANDSCAPING
- NEW ASPHALT
- NEW CONCRETE
- NEW TOPSOIL
- WATER MAIN LINE
- SANITARY SEWER LINE
- STORM SEWER LINE
- UNDERGROUND ELECTRICAL CONDUIT
- UNDERGROUND HIGHVOLTAGE DUCT BANK
- GRADE DIRECTION
- LIGHT STANDARD
- MANHOLE
- VALVE
- CATCH BASIN
- FIRE HYDRANT
- TRANSFORMER

STAMP:

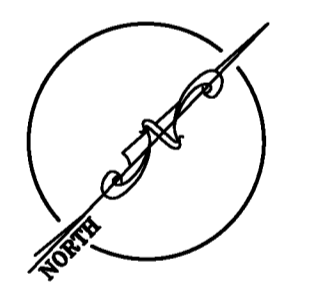

Department of Facilities Management
This University was raised by the people of Newfoundland as a memorial to the fallen in the great wars, 1914-1918, 1939-1945, that in freedom of learning, their cause and sacrifice might not be forgotten.
- Dedication plaque, Arts & Administration Building, St. John's Campus

PROJECT NAME:
CONCRETE AND ASPHALT REPAIRS 2024
Project #: GRD-508-23

DRAWING TITLE:
MAIN DINING HALL DEMOLITION AND NEW SITE PLANS

DESIGNED: S.C./C.B	DRAWN: S.C
REVIEWED: H.H	APPROVED: H.H
SCALE: AS SHOWN	DATE: MAR 28 2024
MUN PROJECT No. GRD-508-23	DRAWING No. C-1.5

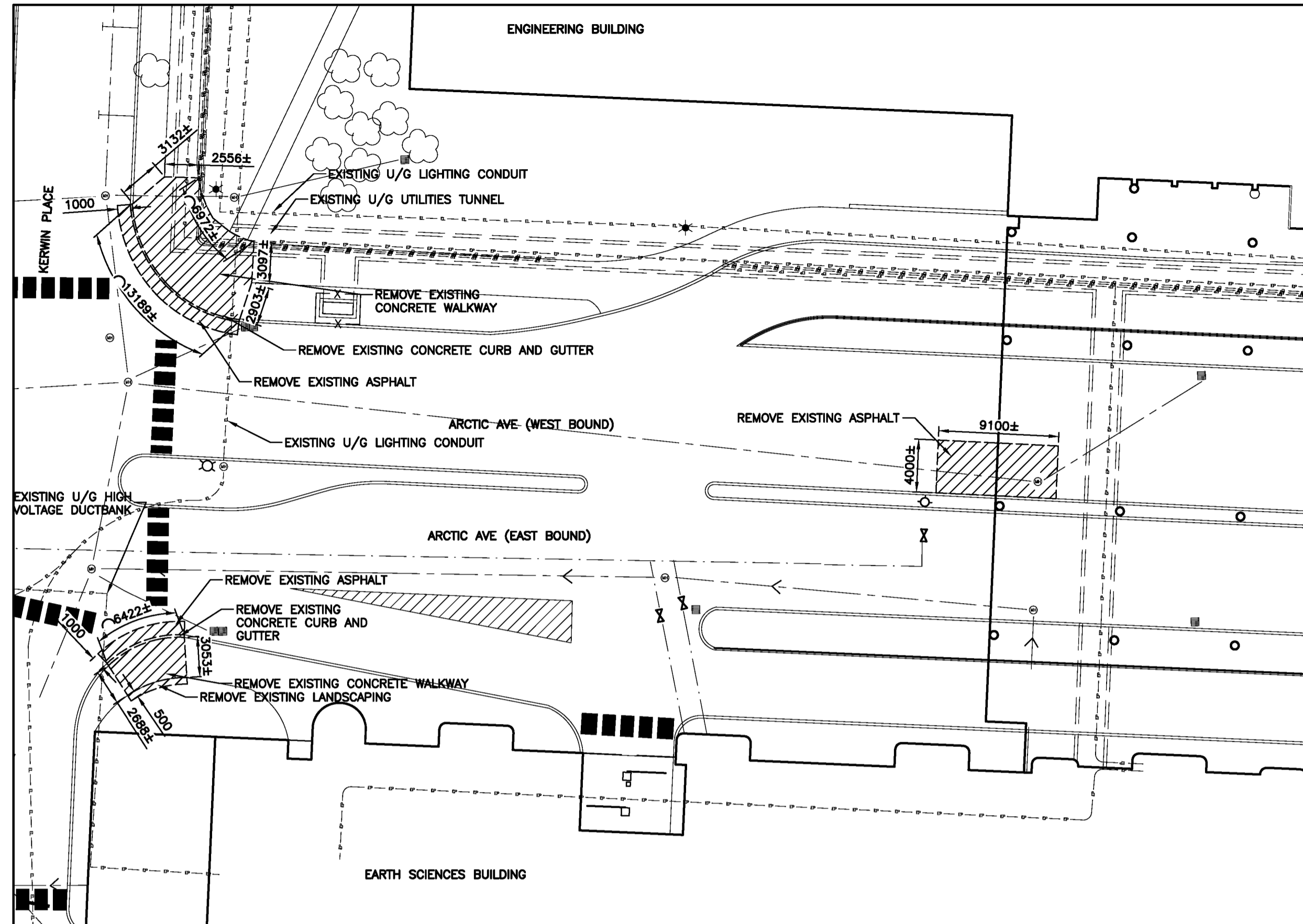

DEMOLITION SITE PLAN
SCALE: 1:300

1
C-1.6

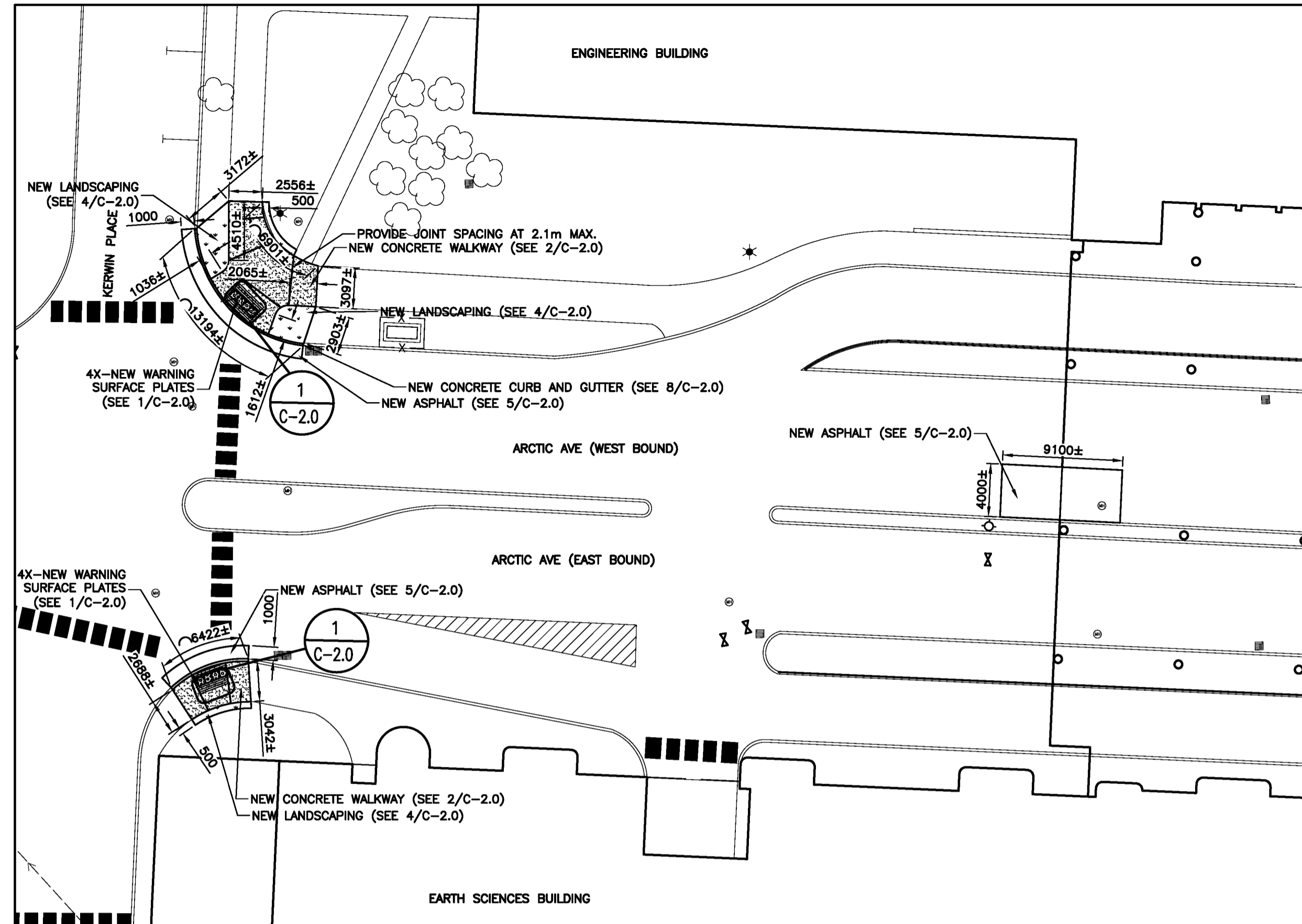

NEW SITE PLAN
SCALE: 1:300

2
C-1.6

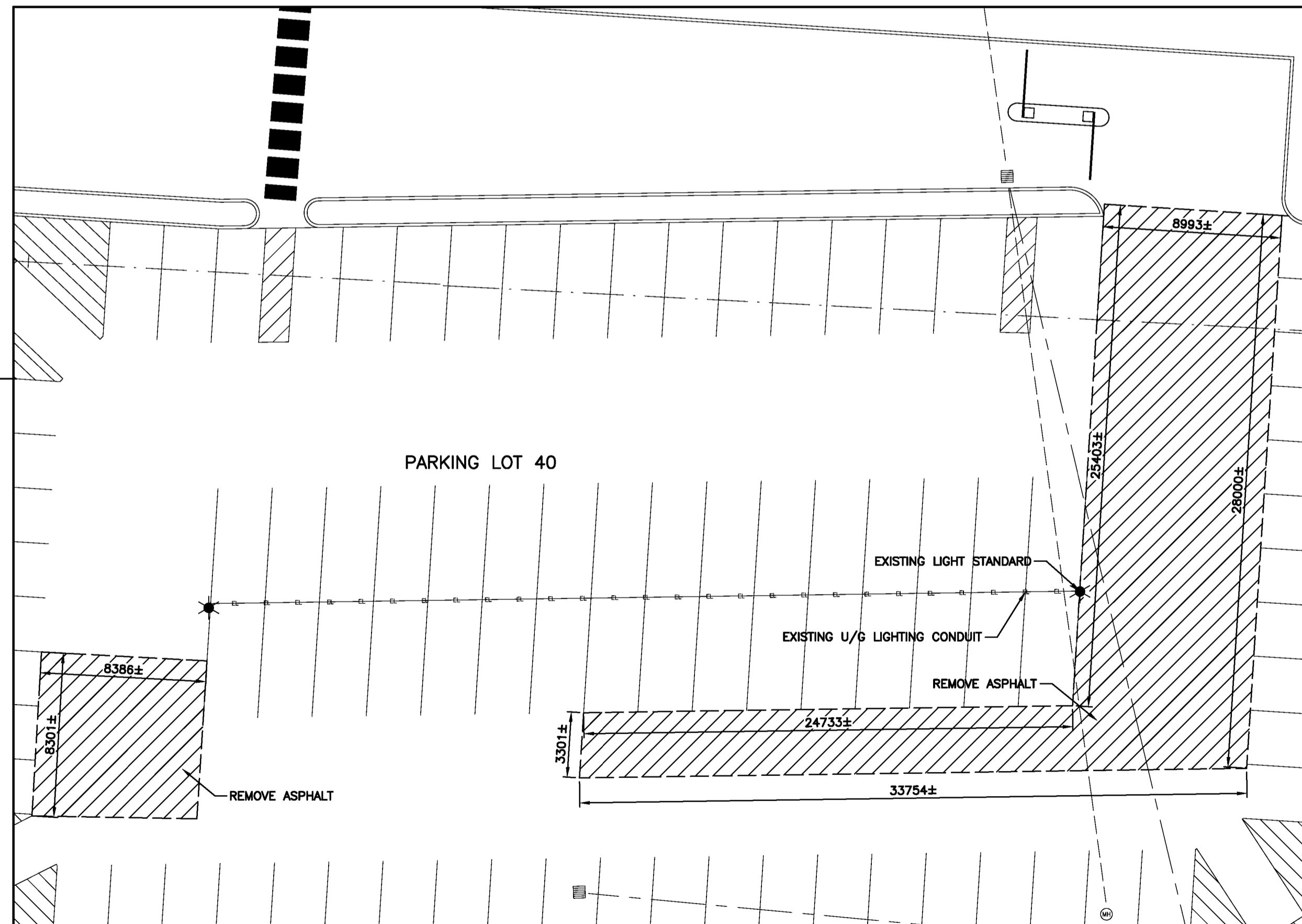

DEMOLITION SITE PLAN
SCALE: 1:200

3
C-1.6

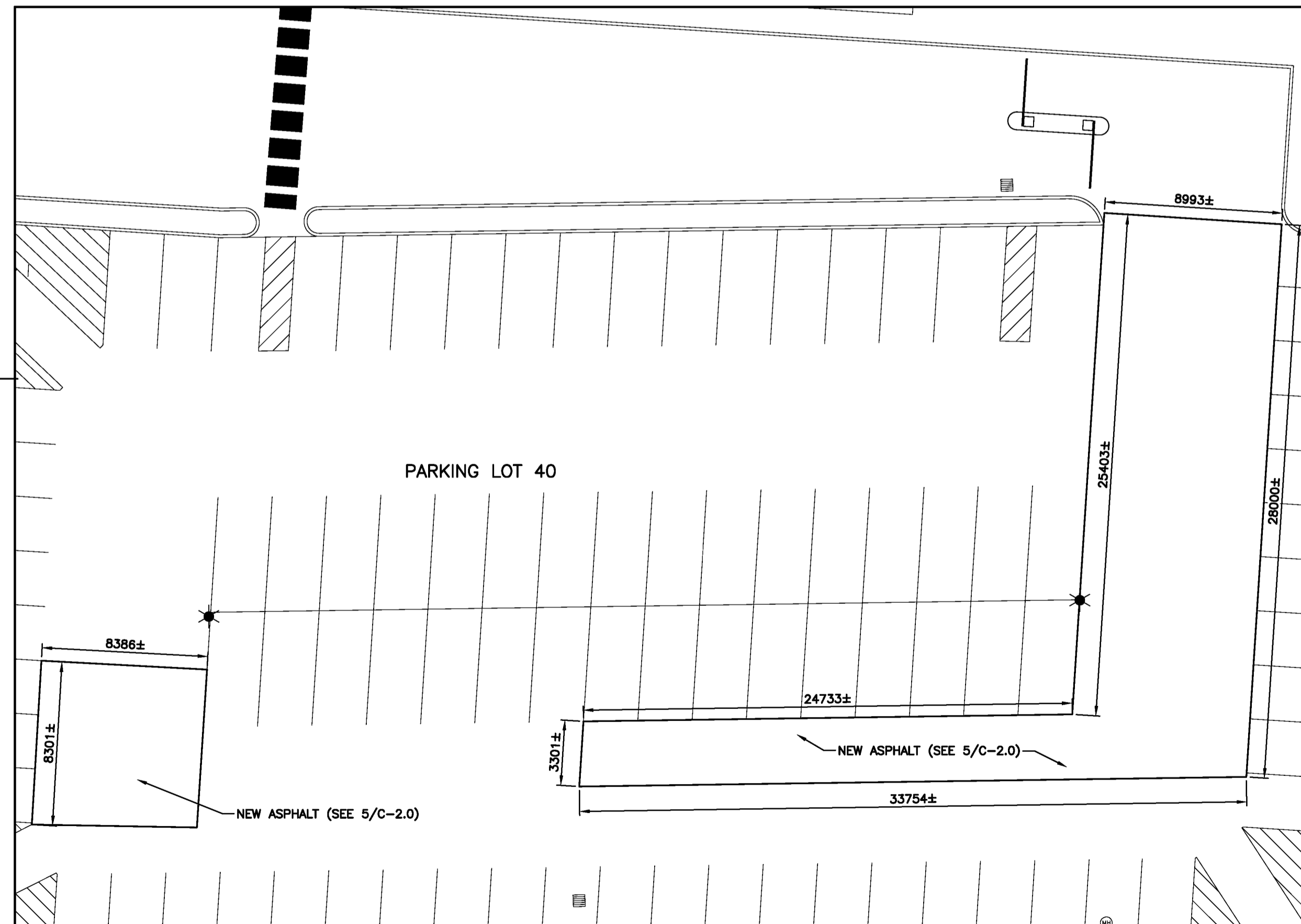

NEW SITE PLAN
SCALE: 1:200

4
C-1.6

No.	REVISION	DATE
R1	ISSUED FOR TENDER	MAR 28, 2024
R0	ISSUED FOR REVIEW	MAR 14, 2024

GENERAL NOTES

- DO NOT SCALE FROM DRAWINGS.
- ALL DIMENSIONS IN MILLIMETRES UNLESS OTHERWISE NOTED.
- THE CONTRACTOR IS TO VERIFY ALL DIMENSIONS AND SITE CONDITIONS PRIOR TO SUBMISSION OF TENDERS.
- ALL DEFICIENCIES FOUND IN THIS DRAWING IS TO BE BROUGHT TO THE ATTENTION OF THE FACILITIES ENGINEERING AND DEVELOPMENT OFFICE OF THE DEPARTMENT OF FACILITIES MANAGEMENT, MEMORIAL UNIVERSITY OF NEWFOUNDLAND, PRIOR TO THE SUBMISSION OF THE TENDERS.

LEGEND

- REMOVAL
- NEW LANDSCAPING
- NEW ASPHALT
- NEW CONCRETE
- NEW TOPSOIL
- WATER MAIN LINE
- SANITARY SEWER LINE
- STORM SEWER LINE
- UNDERGROUND ELECTRICAL CONDUIT
- UNDERGROUND HIGH-VOLTAGE DUCT BANK
- GRADE DIRECTION
- LIGHT STANDARD
- MANHOLE
- VALVE
- CATCH BASIN
- FIRE HYDRANT
- TRANSFORMER

STAMP:

Department of Facilities Management
This University was raised by the people of Newfoundland as a memorial to the fallen in the great wars, 1914-1918, 1939-1945, that in freedom of learning, their cause and sacrifice might not be forgotten.
- Dedication plaque, Arts & Administration Building, St. John's Campus

PROJECT NAME:
CONCRETE AND ASPHALT REPAIRS 2024
Project #: GRD-508-23

DRAWING TITLE:
ARCTIC AVE AND PARKING LOT 40 DEMOLITION AND NEW SITE PLANS

DESIGNED: S.C/C.B	DRAWN: S.C
REVIEWED: H.H	APPROVED: H.H
SCALE: AS SHOWN	DATE: MAR 28 2024
MUN PROJECT No. GRD-508-23	DRAWING No. C-1.6

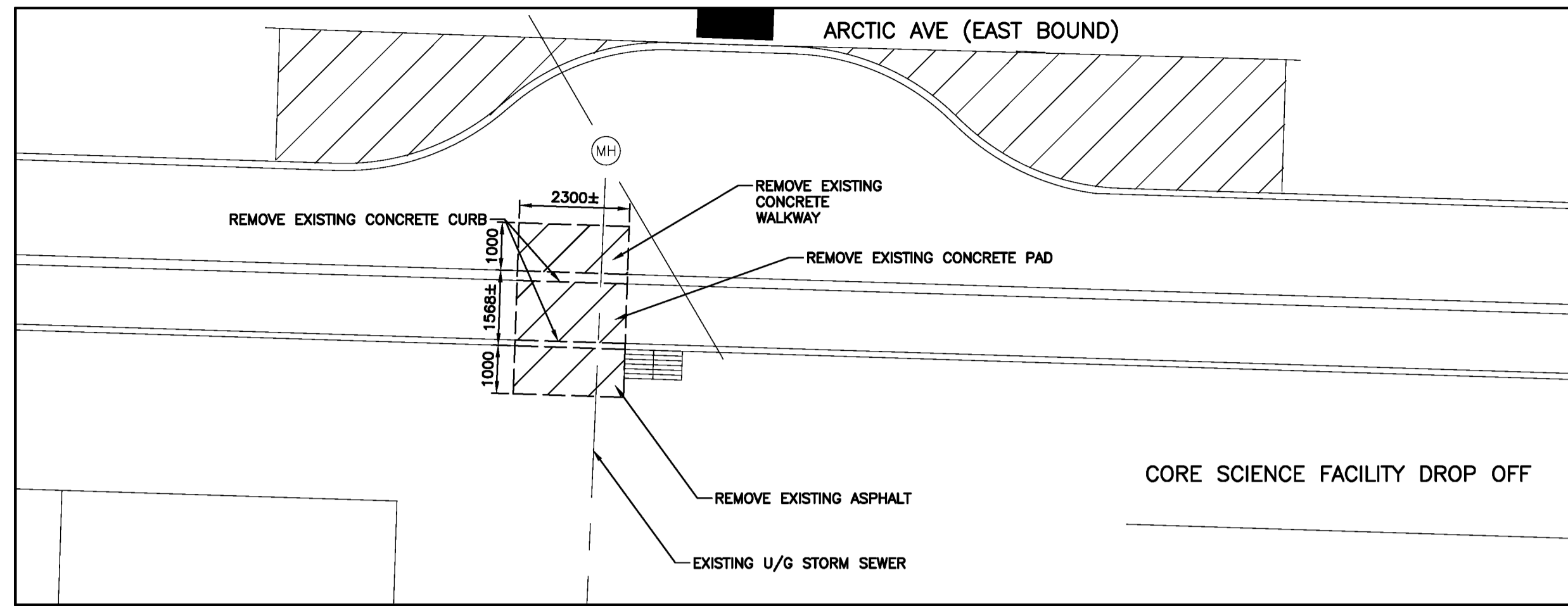

DEMOLITION SITE PLAN
SCALE: 1:100

1
C-1.7

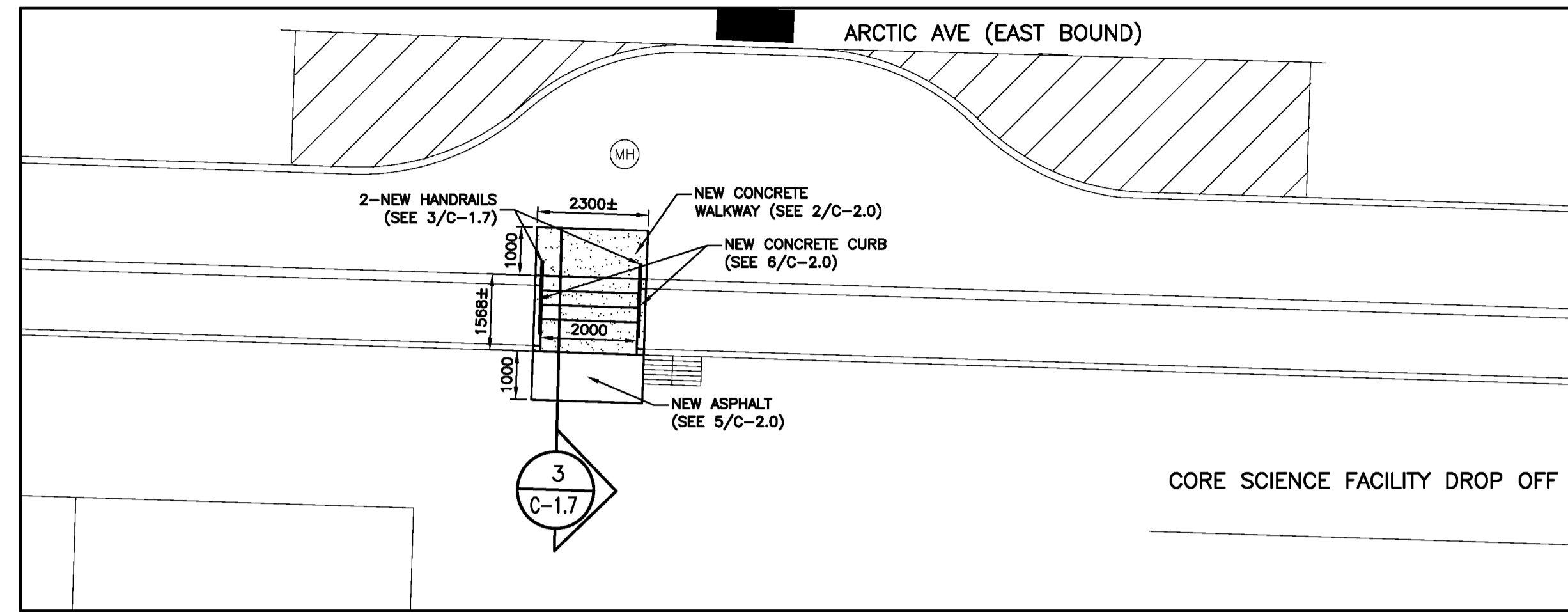

NEW SITE PLAN
SCALE: 1:100

2
C-1.1

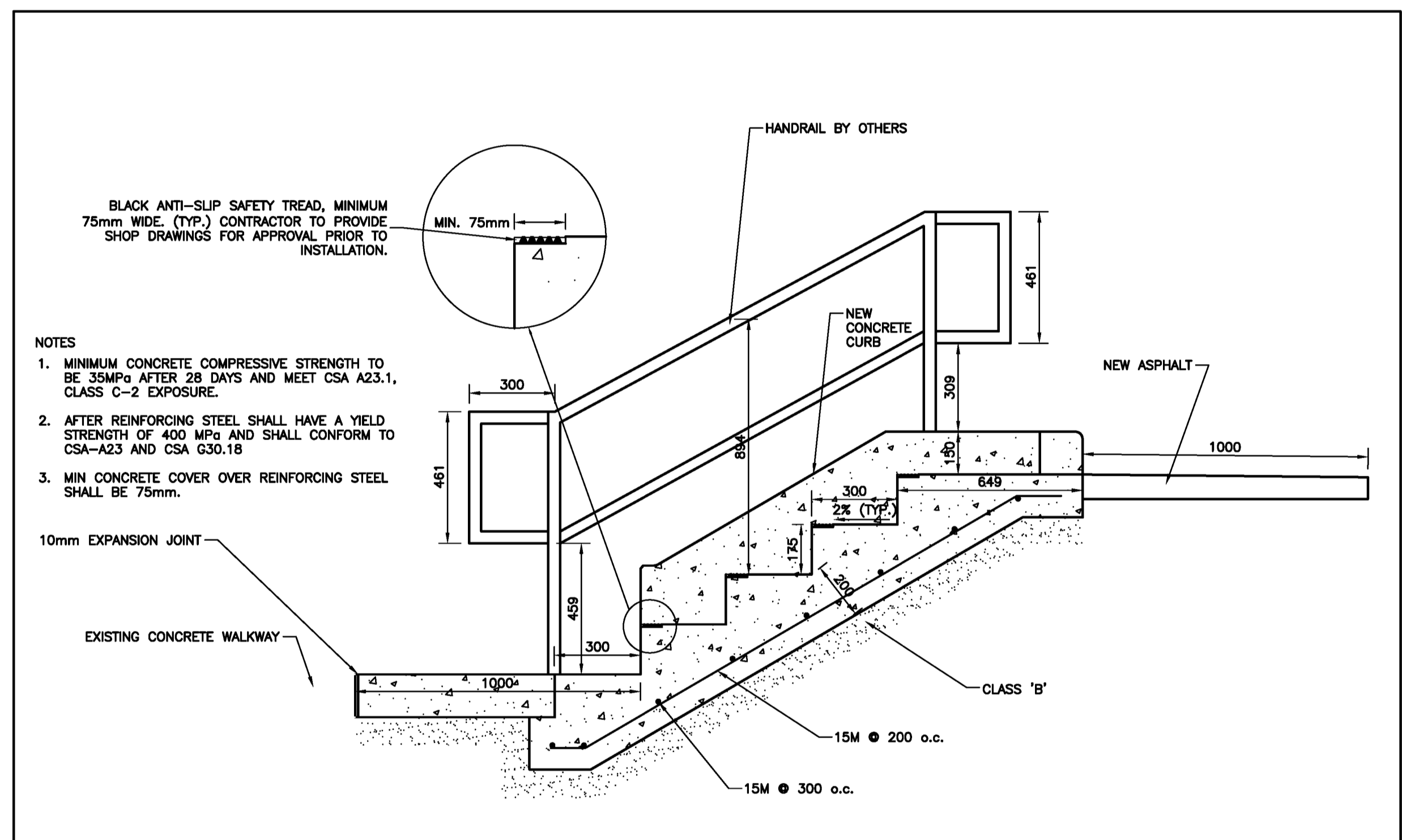

NEW STAIR AND HANDRAIL SECTION
SCALE: 1:15

4
C-1.7

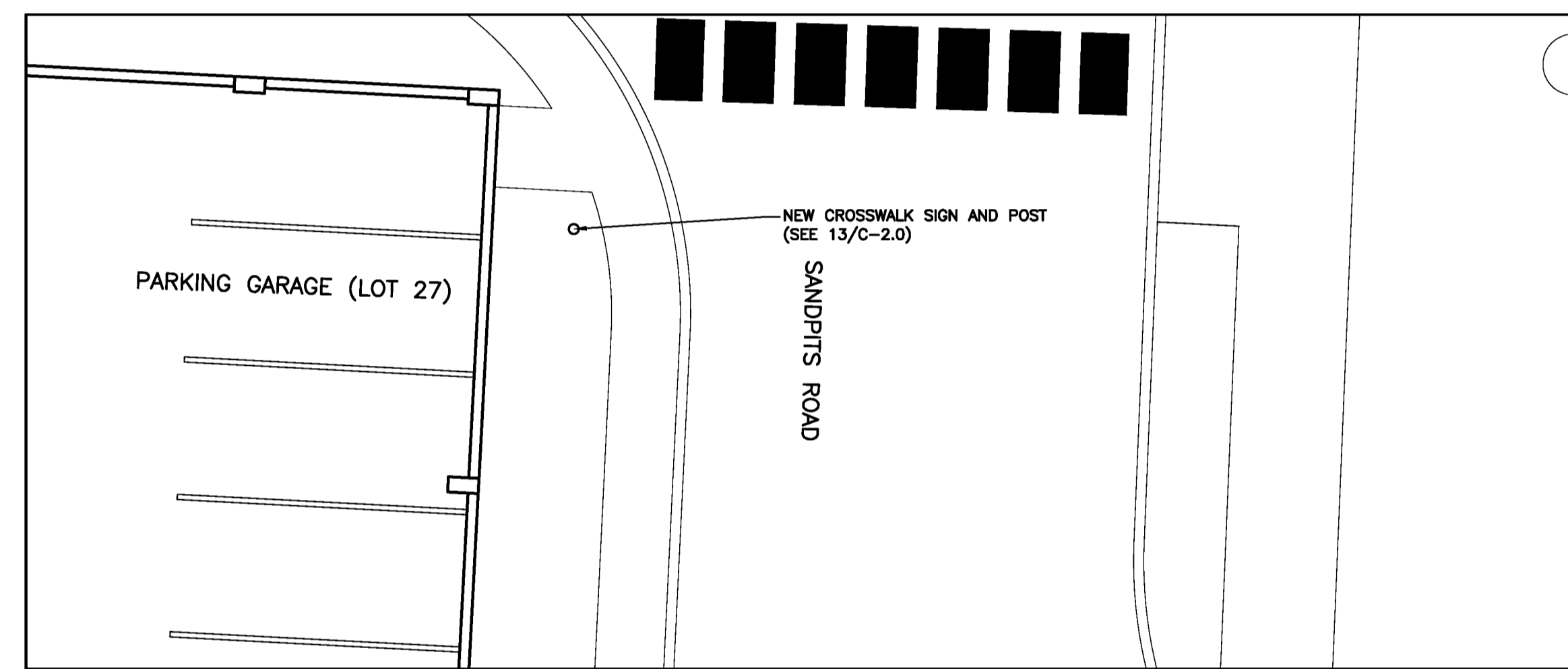

NEW SITE PLAN
SCALE: 1:100

4
C-1.7

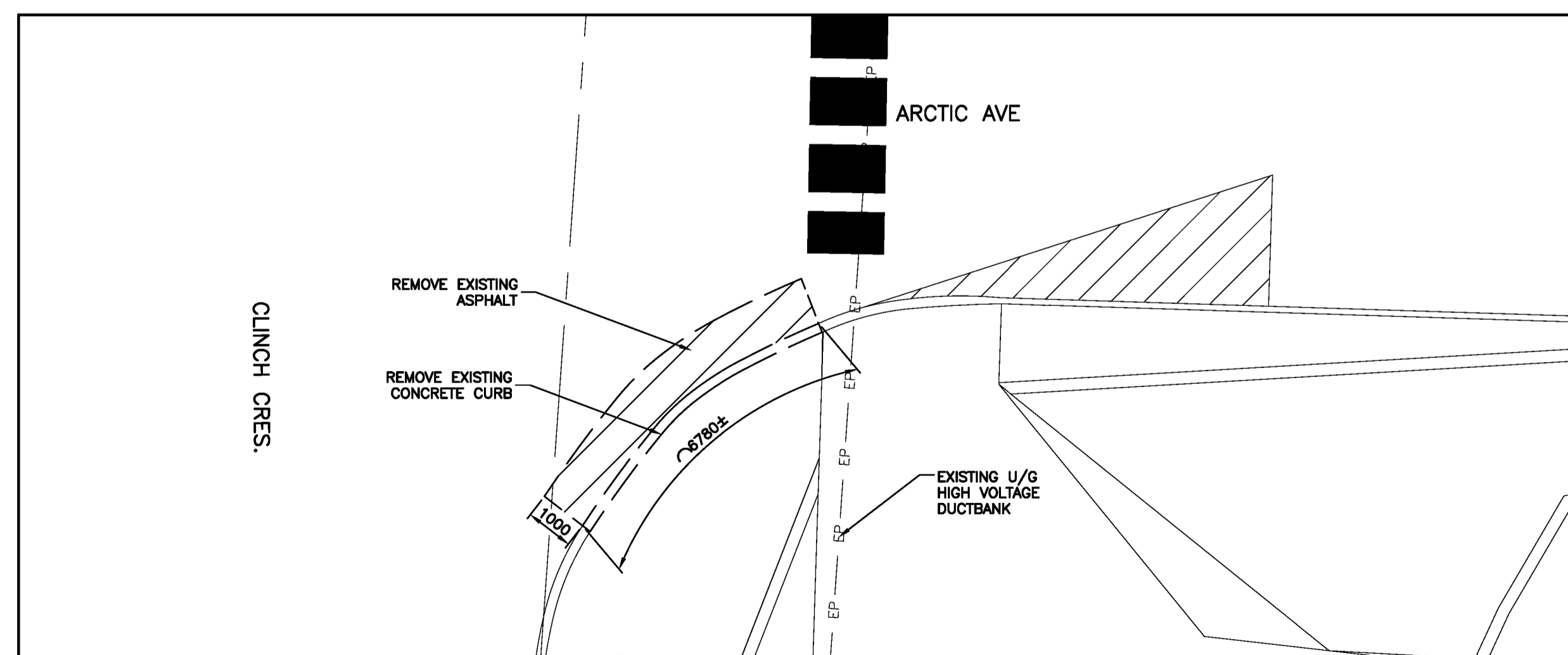

DEMOLITION SITE PLAN
SCALE: 1:100

6
C-1.7

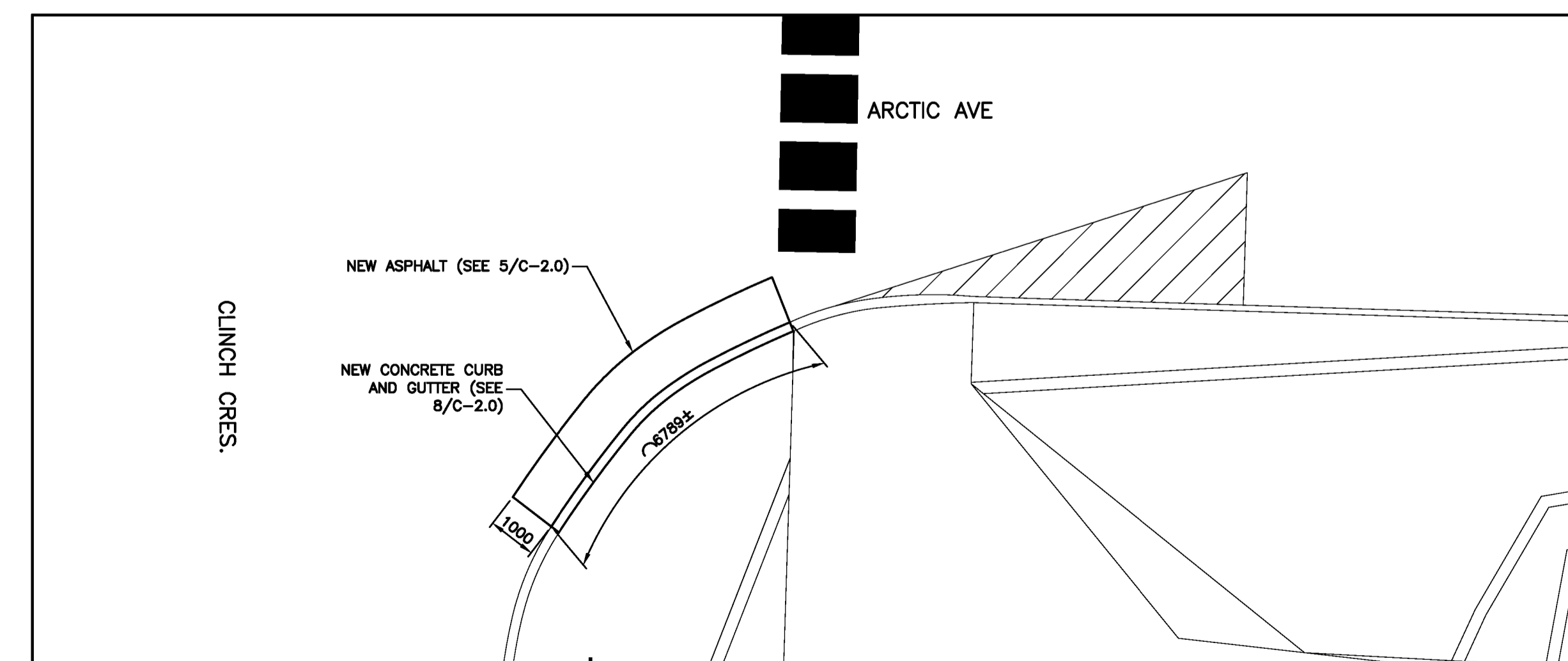

NEW SITE PLAN
SCALE: 1:100

7
C-1.7

No.	REVISION	DATE
R1	ISSUED FOR TENDER	MAR 28, 2024
RO	ISSUED FOR REVIEW	MAR 14, 2024

GENERAL NOTES

- DO NOT SCALE FROM DRAWINGS.
- ALL DIMENSIONS IN MILLIMETRES UNLESS OTHERWISE NOTED.
- THE CONTRACTOR IS TO VERIFY ALL DIMENSIONS AND SITE CONDITIONS PRIOR TO SUBMISSION OF TENDERS.
- ALL DEFICIENCIES FOUND IN THIS DRAWING IS TO BE BROUGHT TO THE ATTENTION OF THE FACILITIES ENGINEERING AND DEVELOPMENT OFFICE OF THE DEPARTMENT OF FACILITIES MANAGEMENT, MEMORIAL UNIVERSITY OF NEWFOUNDLAND, PRIOR TO THE SUBMISSION OF THE TENDERS.

LEGEND

	REMOVAL
	NEW LANDSCAPING
	NEW ASPHALT
	NEW CONCRETE
	NEW TOPSOIL
	WATER MAIN LINE
	SANITARY SEWER LINE
	STORM SEWER LINE
	UNDERGROUND ELECTRICAL CONDUIT
	UNDERGROUND HIGH-VOLTAGE DUCT BANK
	GRADE DIRECTION
	LIGHT STANDARD
	MANHOLE
	VALVE
	CATCH BASIN
	FIRE HYDRANT
	TRANSFORMER

STAMP:

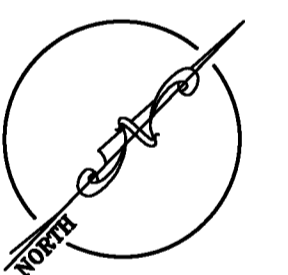

Department of Facilities Management
This University was raised by the people of Newfoundland as a memorial to the fallen in the great wars, 1914-1918, 1939-1945, that in freedom of learning, their cause and sacrifice might not be forgotten.
- Dedication plaque, Arts & Administration Building, St. John's Campus

PROJECT NAME:

CONCRETE AND ASPHALT
REPAIRS 2024

Project #: GRD-508-23

DRAWING TITLE:

CORE SCIENCE FACILITY AND
ARCTIC AVE AT CLINCH CRESENT
DEMOLITION AND NEW SITE PLANS

DESIGNED:

S.C./C.B

DRAWN:

S.C

REVIEWED:

H.H

APPROVED:

H.H

SCALE:

AS SHOWN

DATE:

MAR 28 2024

MUN PROJECT No.

GRD-508-23

DRAWING No.

C-1.7

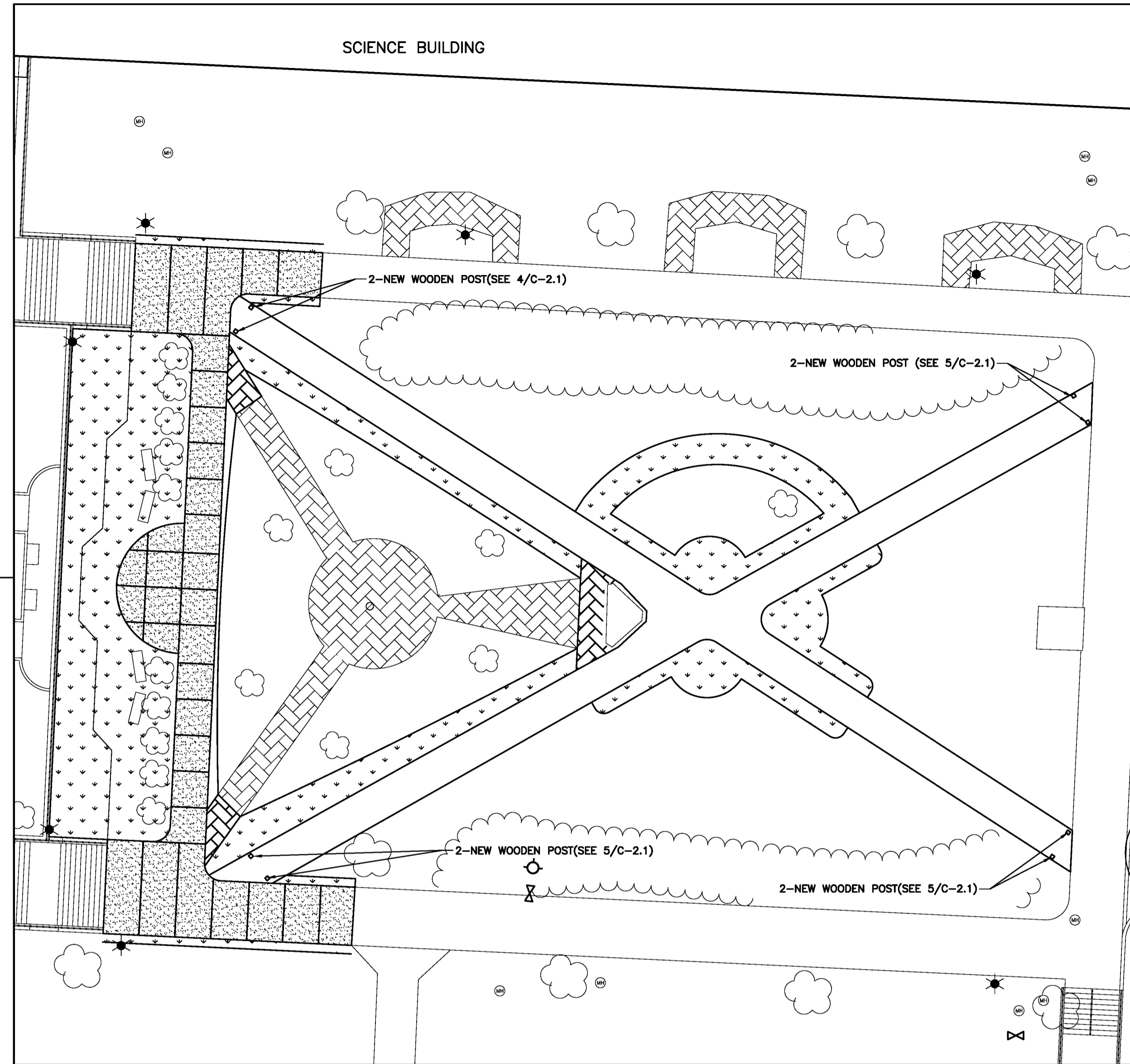

NEW BOLLARD (WOODEN)
SCALE: 1:200

1
C-1.8

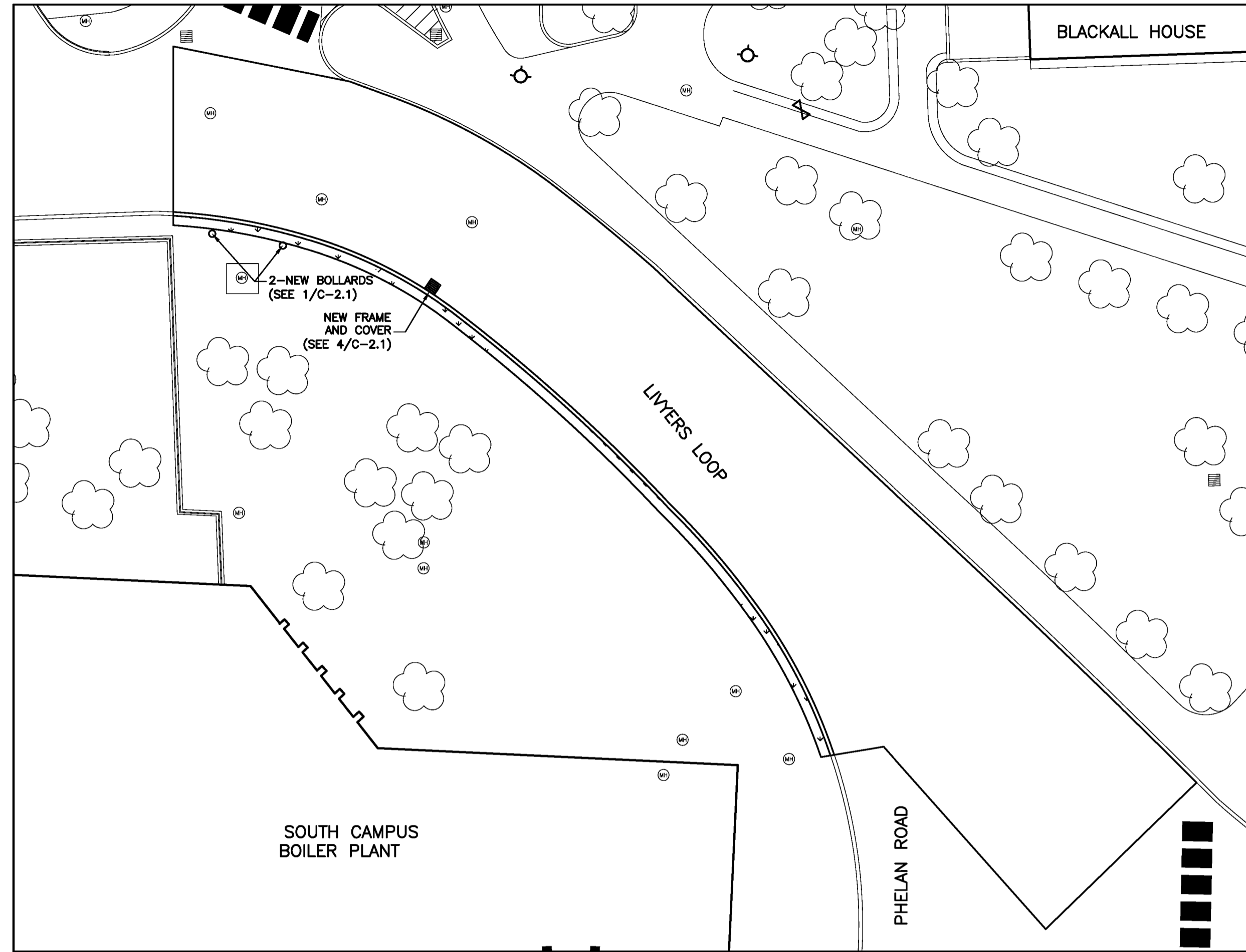

NEW BOLLARD (METAL) AND CATCH BASIN FRAME AND COVER
SCALE: 1:200

2
C-1.8

No.	REVISION	DATE
R1	ISSUED FOR TENDER	MAR 28, 2024
R0	ISSUED FOR REVIEW	MAR 14, 2024

GENERAL NOTES

- DO NOT SCALE FROM DRAWINGS.
- ALL DIMENSIONS IN MILLIMETRES UNLESS OTHERWISE NOTED.
- THE CONTRACTOR IS TO VERIFY ALL DIMENSIONS AND SITE CONDITIONS PRIOR TO SUBMISSION OF TENDERS.
- ALL DEFICIENCIES FOUND IN THIS DRAWING IS TO BE BROUGHT TO THE ATTENTION OF THE FACILITIES ENGINEERING AND DEVELOPMENT OFFICE OF THE DEPARTMENT OF FACILITIES MANAGEMENT, MEMORIAL UNIVERSITY OF NEWFOUNDLAND, PRIOR TO THE SUBMISSION OF THE TENDERS.

LEGEND

- REMOVAL
- NEW LANDSCAPING
- NEW ASPHALT
- NEW CONCRETE
- NEW TOPSOIL
- WATER MAIN LINE
- SANITARY SEWER LINE
- STORM SEWER LINE
- UNDERGROUND ELECTRICAL CONDUIT
- UNDERGROUND HIGHVOLTAGE DUCT BANK
- GRADE DIRECTION
- LIGHT STANDARD
- MANHOLE
- VALVE
- CATCH BASIN
- FIRE HYDRANT
- TRANSFORMER

STAMP:

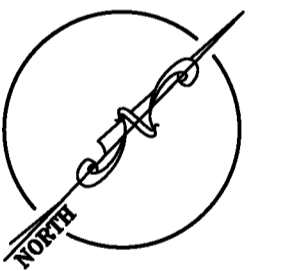

Department of Facilities Management
This University was raised by the people of Newfoundland as a memorial to the fallen in the great wars, 1914-1918, 1939-1945, that in freedom of learning, their cause and sacrifice might not be forgotten.
- Dedication plaque, Arts & Administration Building, St. John's Campus

PROJECT NAME:

CONCRETE AND ASPHALT
REPAIRS 2024

Project #: GRD-508-23

DRAWING TITLE:

BOLLARD (WOODEN/ METAL)
LOCATIONS AND CATCH BASIN
FRAME AND COVER LOCATION

DESIGNED:

S.C/C.B

DRAWN:

S.C

REVIEWED:

H.H

APPROVED:

H.H

SCALE:

AS SHOWN

DATE:

MAR 28 2024

MUN PROJECT No.

GRD-508-23

DRAWING No.

C-1.8

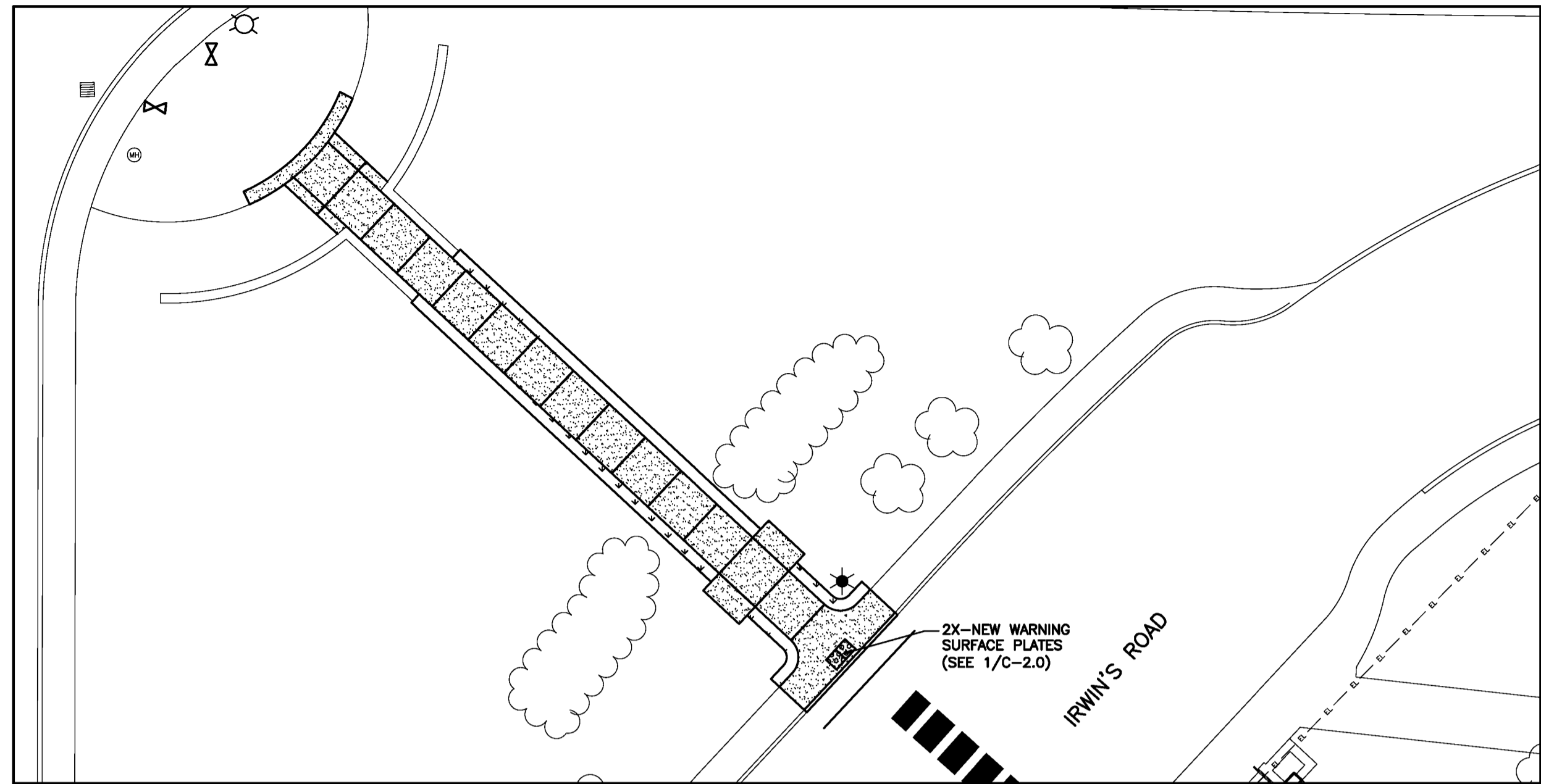

NEW WARNING SURFACE PLATE LOCATIONS
SCALE: 1:200

1
C-1.9

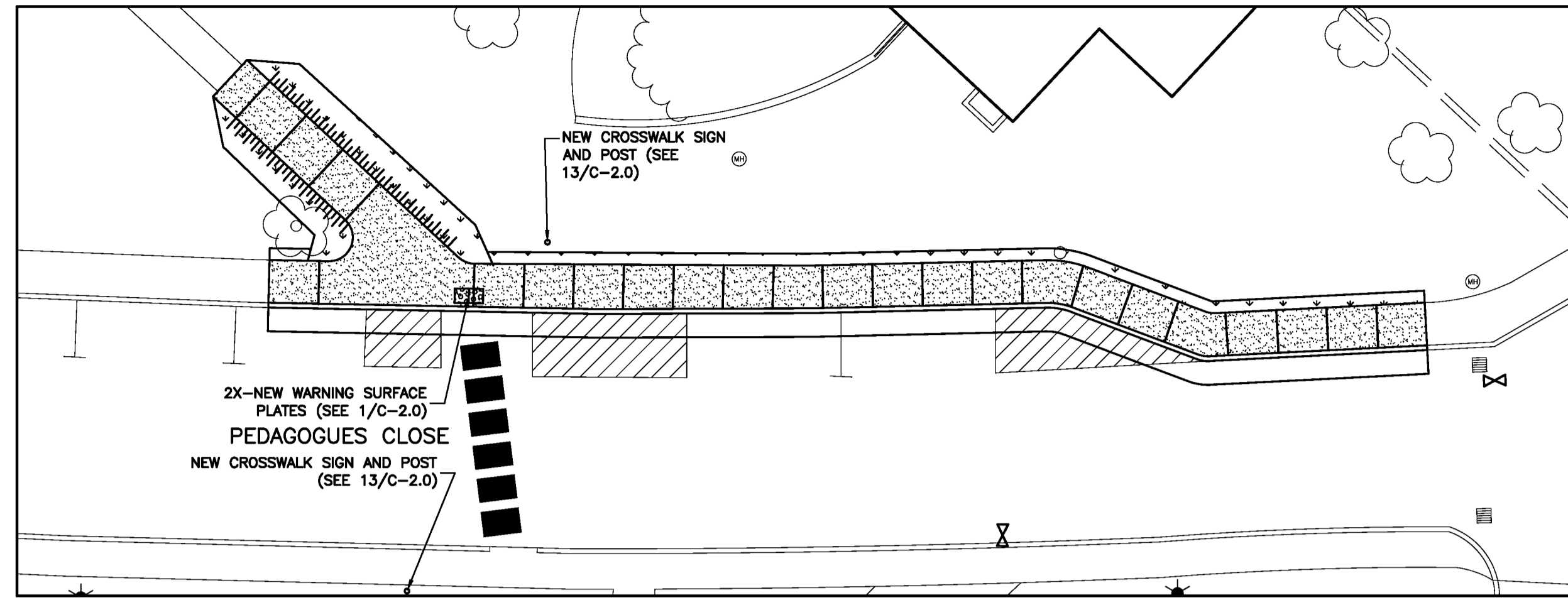

NEW WARNING SURFACE PLATE LOCATIONS AND SIGN POST LOCATION
SCALE: 1:200

2
C-1.9

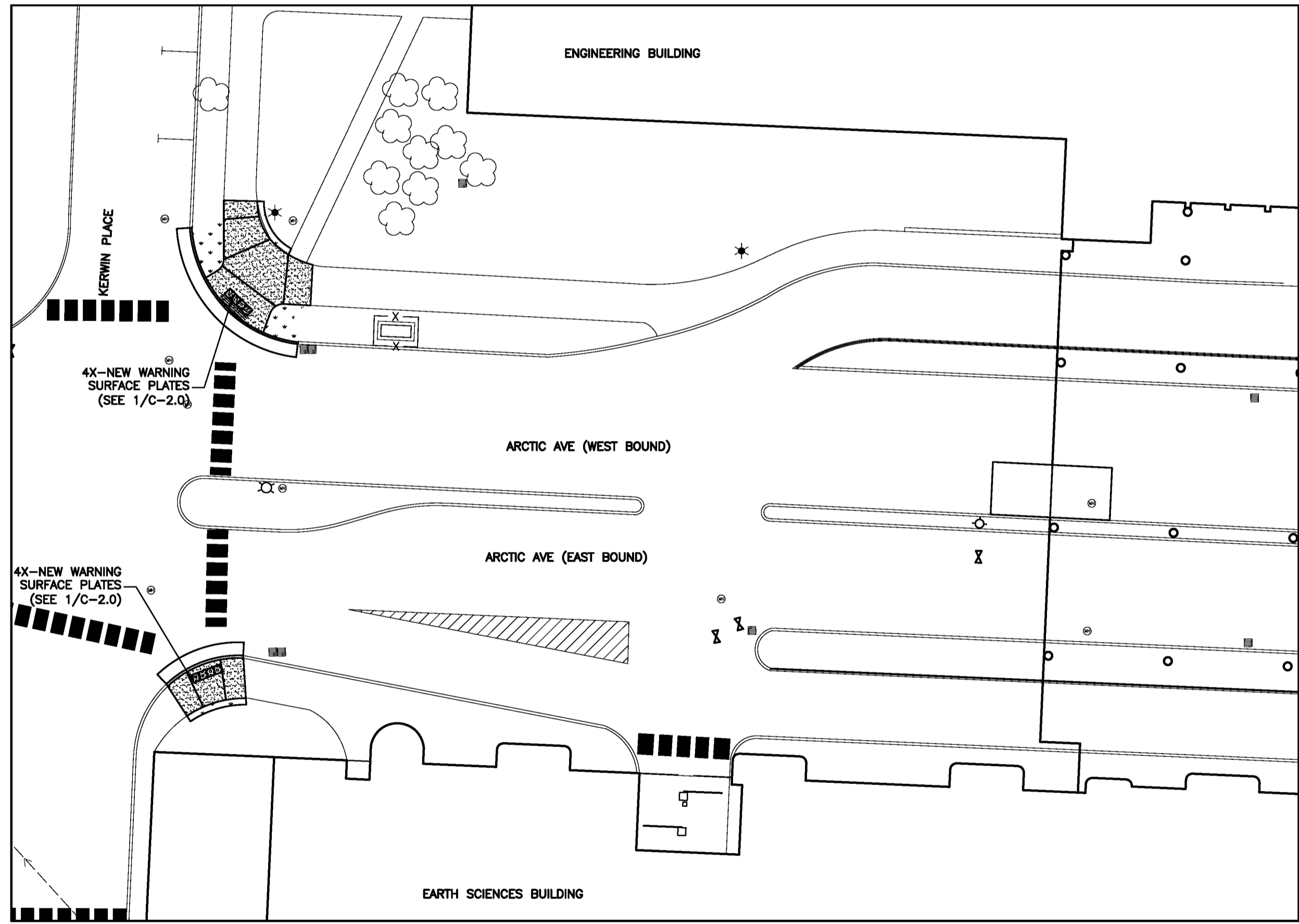

NEW SITE PLAN
SCALE: 1:300

3
C-1.9

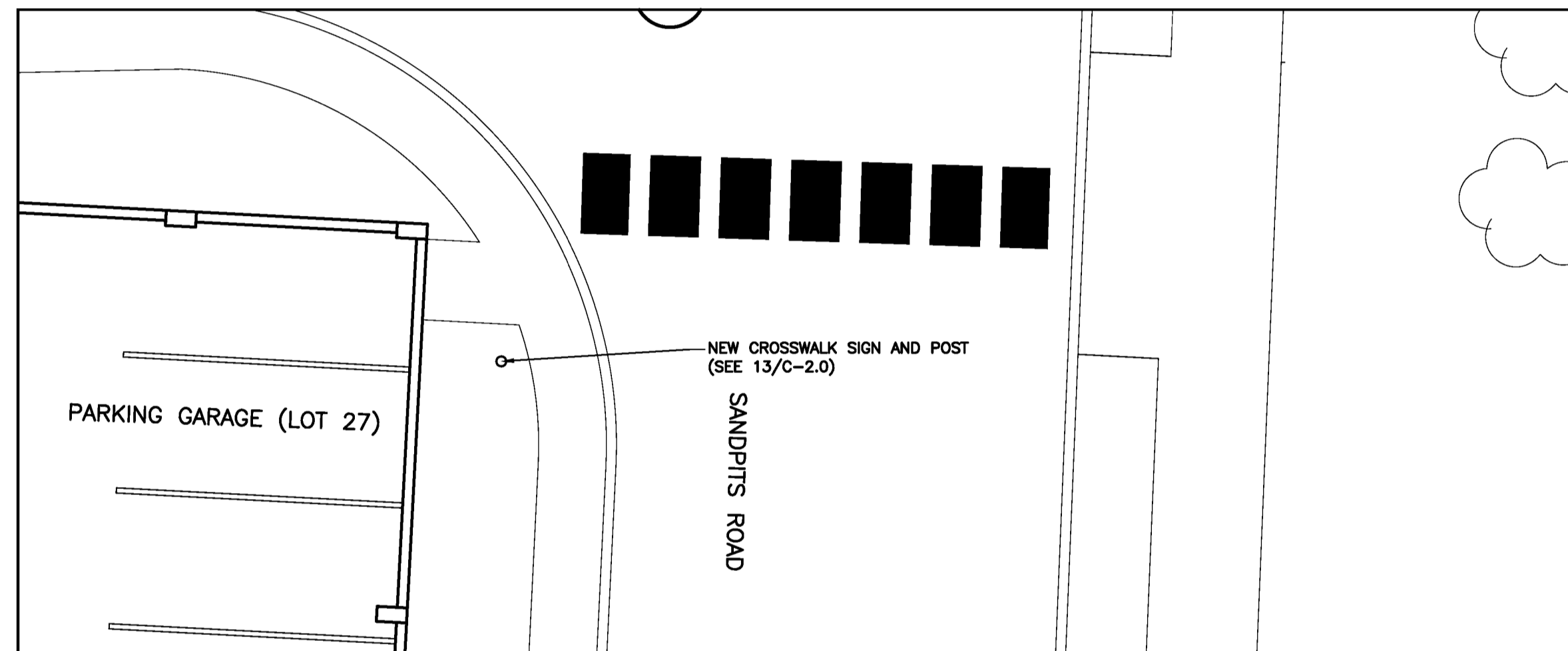

NEW SIGN POST LOCATION
SCALE: 1:100

4
C-1.9

No.	REVISION	DATE
R1	ISSUED FOR TENDER	MAR 28, 2024
R0	ISSUED FOR REVIEW	MAR 14, 2024

GENERAL NOTES

- DO NOT SCALE FROM DRAWINGS.
- ALL DIMENSIONS IN MILLIMETRES UNLESS OTHERWISE NOTED.
- THE CONTRACTOR IS TO VERIFY ALL DIMENSIONS AND SITE CONDITIONS PRIOR TO SUBMISSION OF TENDERS.
- ALL DEFICIENCIES FOUND IN THIS DRAWING IS TO BE BROUGHT TO THE ATTENTION OF THE FACILITIES ENGINEERING AND DEVELOPMENT OFFICE OF THE DEPARTMENT OF FACILITIES MANAGEMENT, MEMORIAL UNIVERSITY OF NEWFOUNDLAND, PRIOR TO THE SUBMISSION OF THE TENDERS.

LEGEND

- REMOVAL
- NEW LANDSCAPING
- NEW ASPHALT
- NEW CONCRETE
- NEW TOPSOIL
- WATER MAIN LINE
- SANITARY SEWER LINE
- STORM SEWER LINE
- UNDERGROUND ELECTRICAL CONDUIT
- UNDERGROUND HIGHVOLTAGE DUCT BANK
- GRADE DIRECTION
- LIGHT STANDARD
- MANHOLE
- VALVE
- CATCH BASIN
- FIRE HYDRANT
- TRANSFORMER

STAMP:

Department of Facilities Management
This University was raised by the people of Newfoundland as a memorial to the fallen in the great wars, 1914-1918, 1939-1945, that in freedom of learning, their cause and sacrifice might not be forgotten.
 - Dedication plaque, Arts & Administration Building, St. John's Campus

PROJECT NAME:
CONCRETE AND ASPHALT REPAIRS 2024
 Project #: GRD-508-23

DRAWING TITLE:
WARNING SURFACE PLATE LOCATIONS

DESIGNED: S.C./C.B	DRAWN: S.C
REVIEWED: H.H	APPROVED: H.H
SCALE: AS SHOWN	DATE: MAR 28 2024
MUN PROJECT No. GRD-508-23	DRAWING No. C-1.9

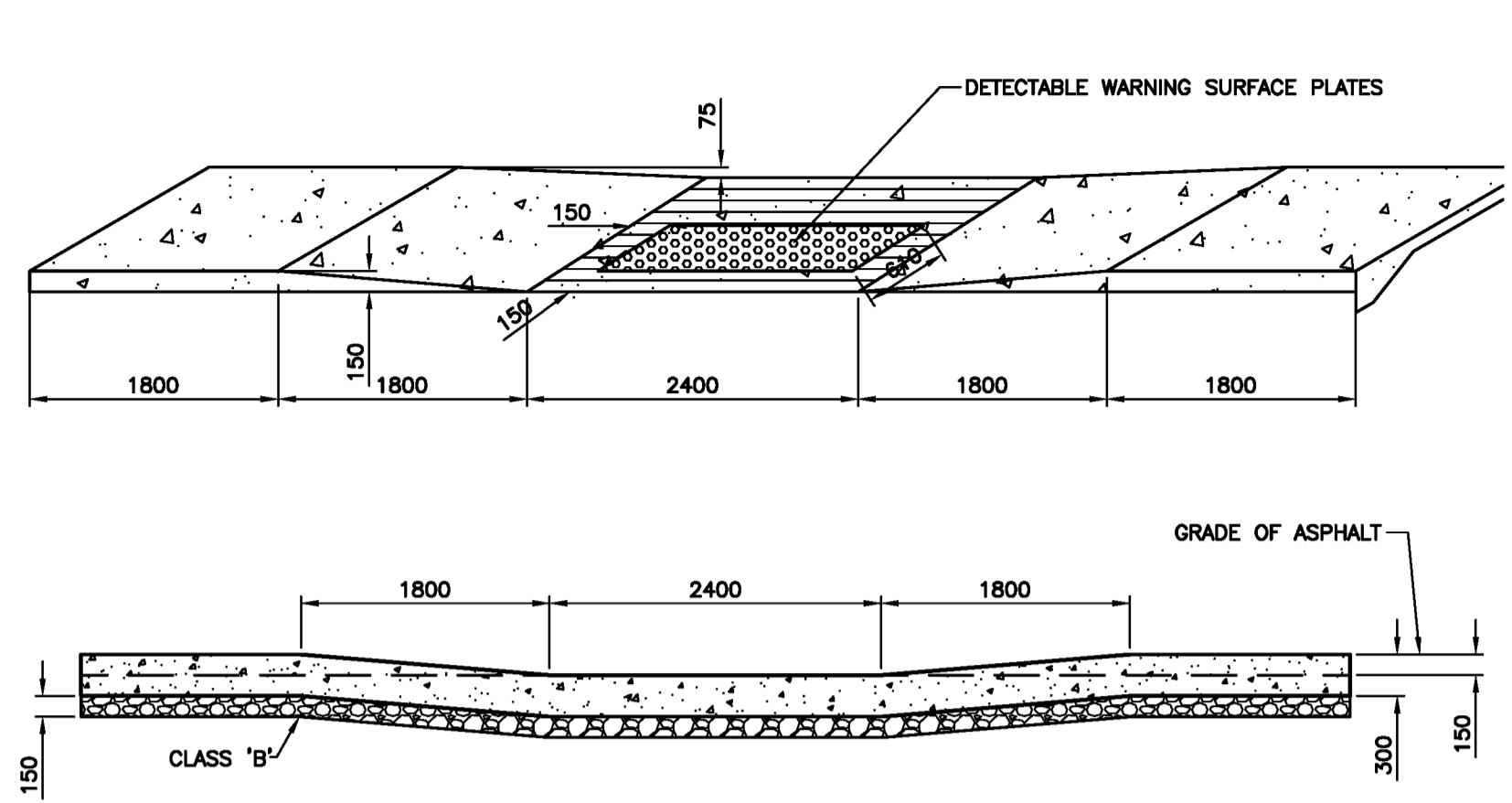

ACCESSIBILITY RAMP DETAIL
SCALE: 1:50

WARNING SURFACE PLATE NOTES:

1. ALL TEXTURED SURFACES USED AS DETECTABLE WARNING SURFACES SHALL BE CLEARLY DETECTABLE BY WALKING UPON AS BEING DIFFERENT FROM THE SURROUNDING SURFACE.
2. DETECTABLE WARNING SURFACES SHALL CONTRAST VISUALLY WITH ADJOINING SURFACES, BEING EITHER LIGHT ON DARK OR DARK ON LIGHT.
3. DETECTABLE WARNING SURFACES SHALL BE SLIP-RESISTANT.
4. DETECTABLE WARNING SURFACES AT CURB RAMPS AND DEPRESSED CURBS SHALL BE COMPOSED OF FLAT-TOPPED DOMES OR CONES THAT ARE 4-5 mm HIGH.
5. IF A WALKWAY CROSSES OR JOINS A VEHICULAR WAY AND THE WALKING SURFACES ARE NOT SEPARATED BY CURBS, RAILINGS OR OTHER ELEMENTS BETWEEN THE PEDESTRIAN AREAS AND VEHICULAR AREAS, THE BOUNDARY BETWEEN THE AREAS SHALL BE DEFINED BY A CONTINUOUS DETECTABLE WARNING SURFACE, FLAT-TOPPED DOMES OR CONES WHICH IS MINIMUM 920mm WIDE.
6. ALL TRUNCATED DOME DETECTABLE WARNING PLATE DESIGNS ARE TO BE FINALIZED BY THE MANUFACTURER, "BIBBY-STÉ-CROIX" OR EQUIVALENT (610mmx610mm SQ.).
7. COLOR OF TRUNCATED DOME PLATES TO BE NATURAL PATINA.

1
C-2.0

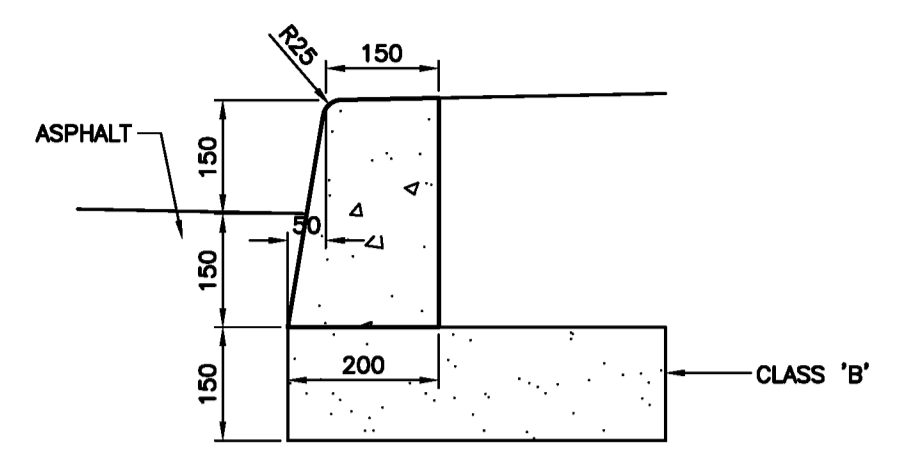

TYPICAL CURB DETAIL
SCALE: 1:10

6
C-2.0

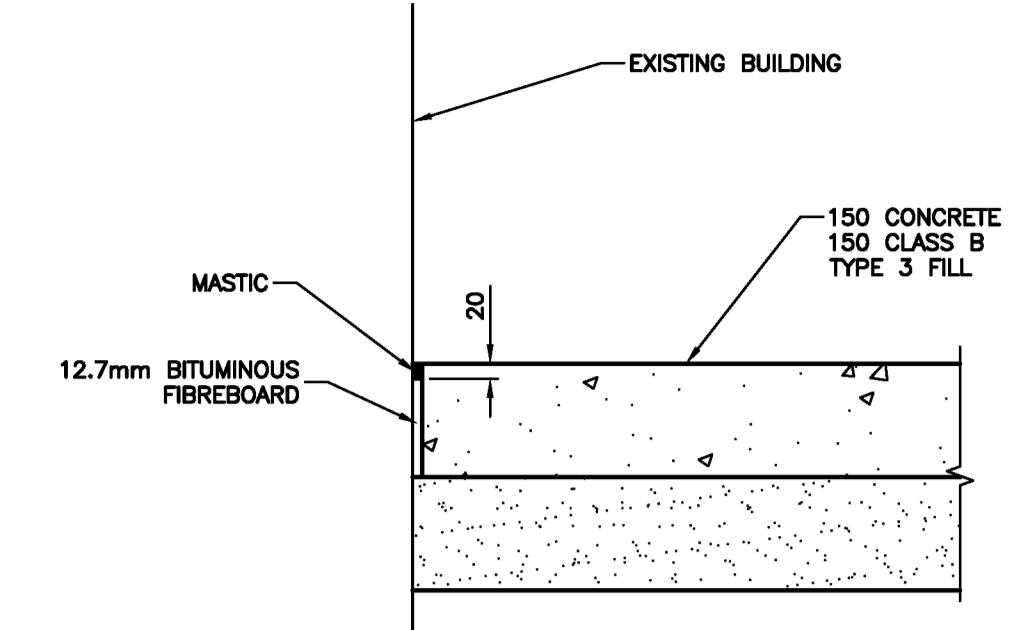

CONCRETE AT BUILDING DETAIL
SCALE: 1:10

11
C-2.0

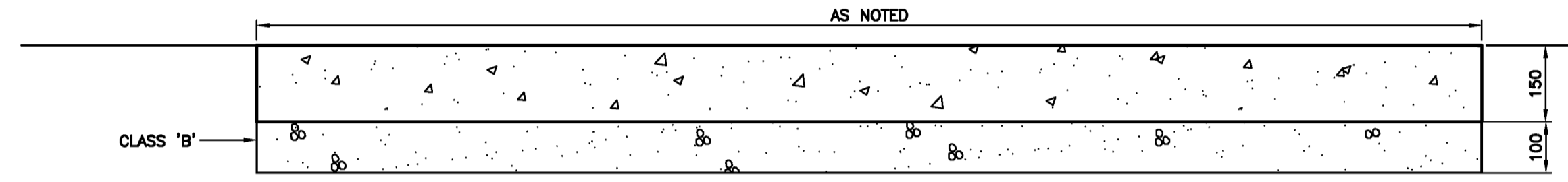

CONCRETE WALKWAY DETAIL
SCALE: 1:10

2
C-2.0

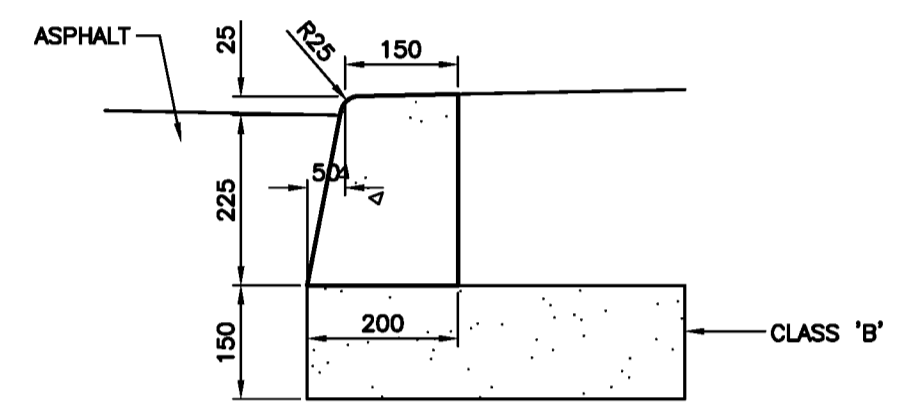

TYPICAL LOWBACK CURB DETAIL
SCALE: 1:10

7
C-2.0

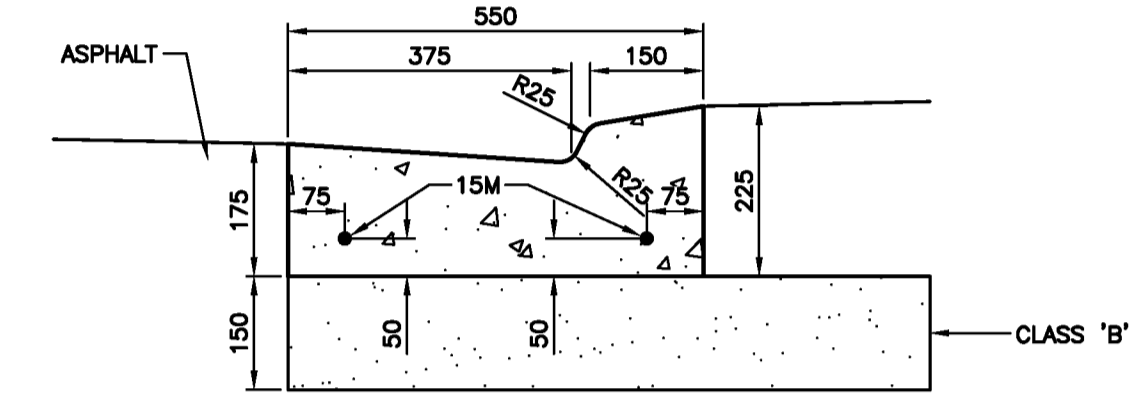

TYPICAL DEPRESSED CURB & GUTTER DETAIL
SCALE: 1:10

12
C-2.0

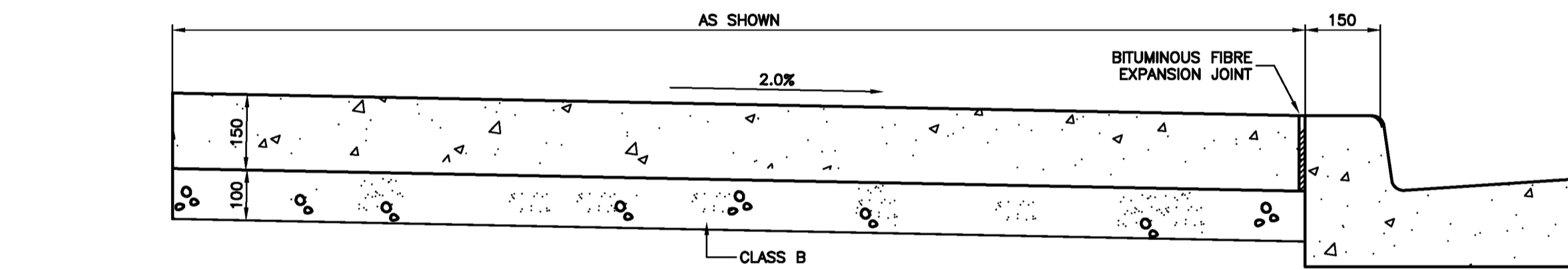

CURB AND SIDEWALK DETAIL
SCALE: 1:10

3
C-2.0

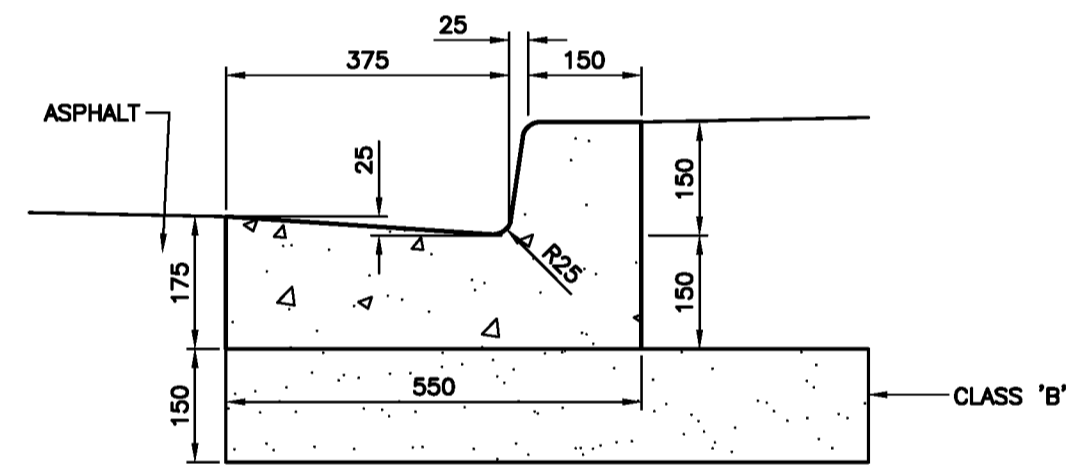

TYPICAL CURB & GUTTER DETAIL
SCALE: 1:10

8
C-2.0

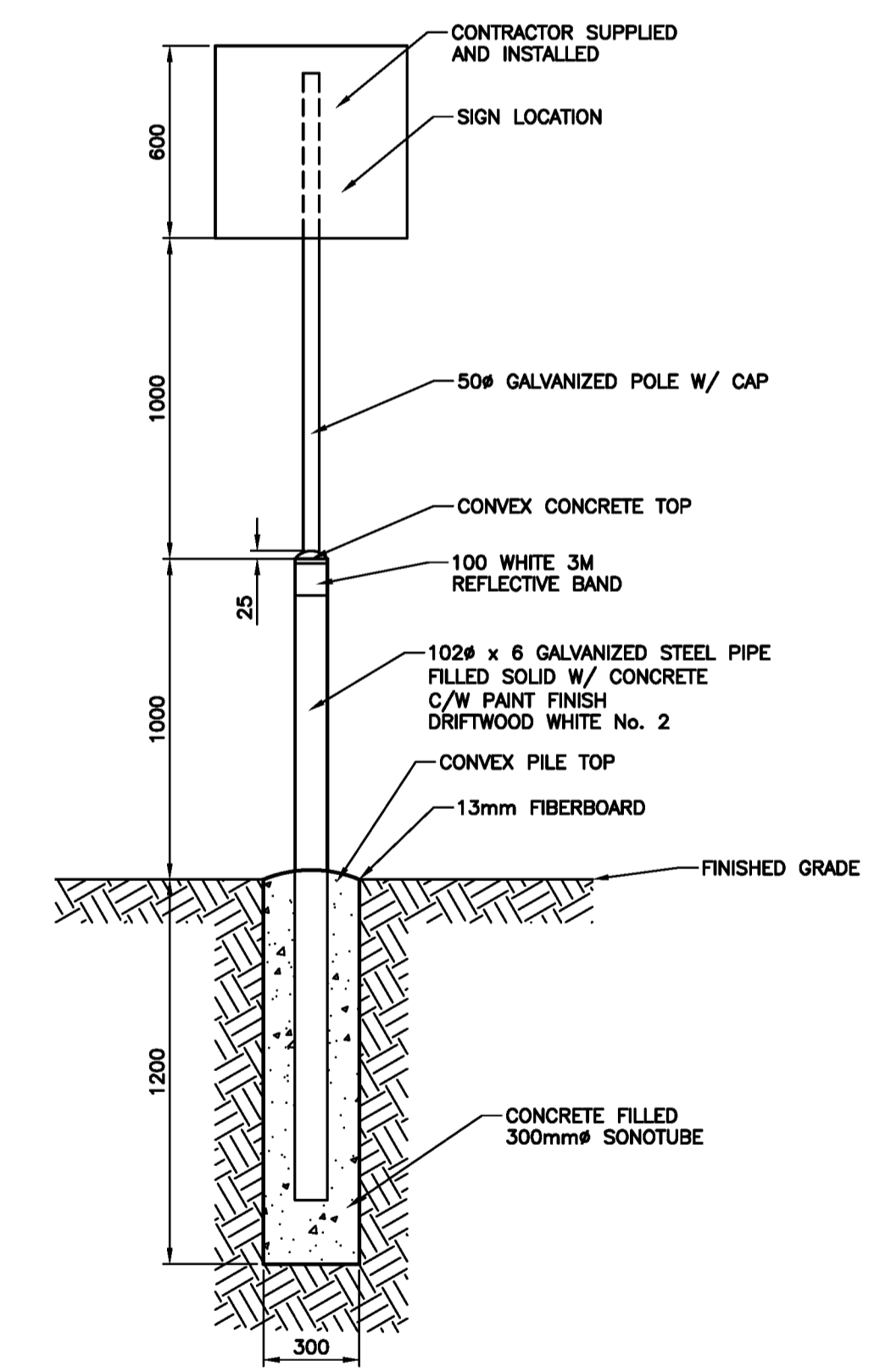

SIGN POST DETAIL
SCALE: 1:20

13
C-2.0

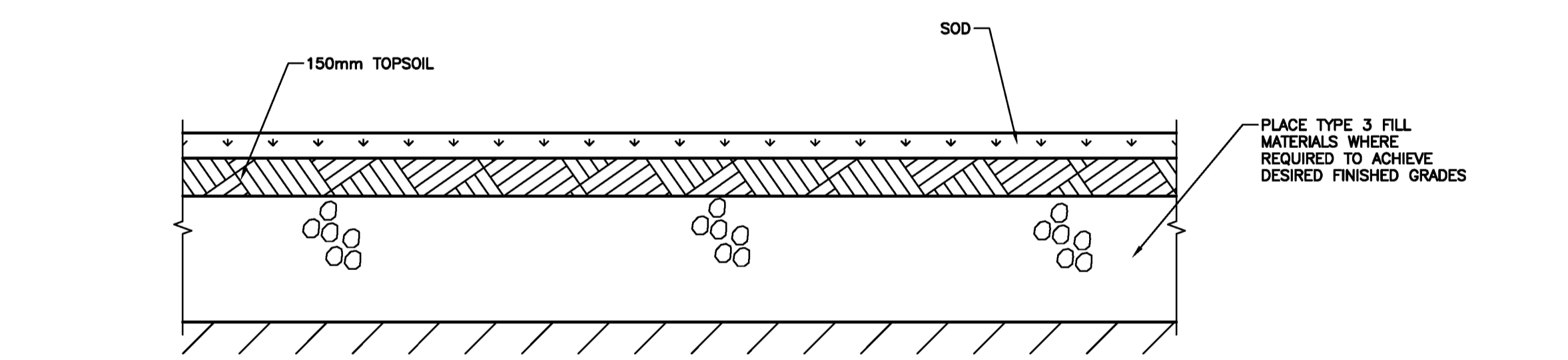

LANDSCAPING DETAIL
SCALE: 1:10

4
C-2.0

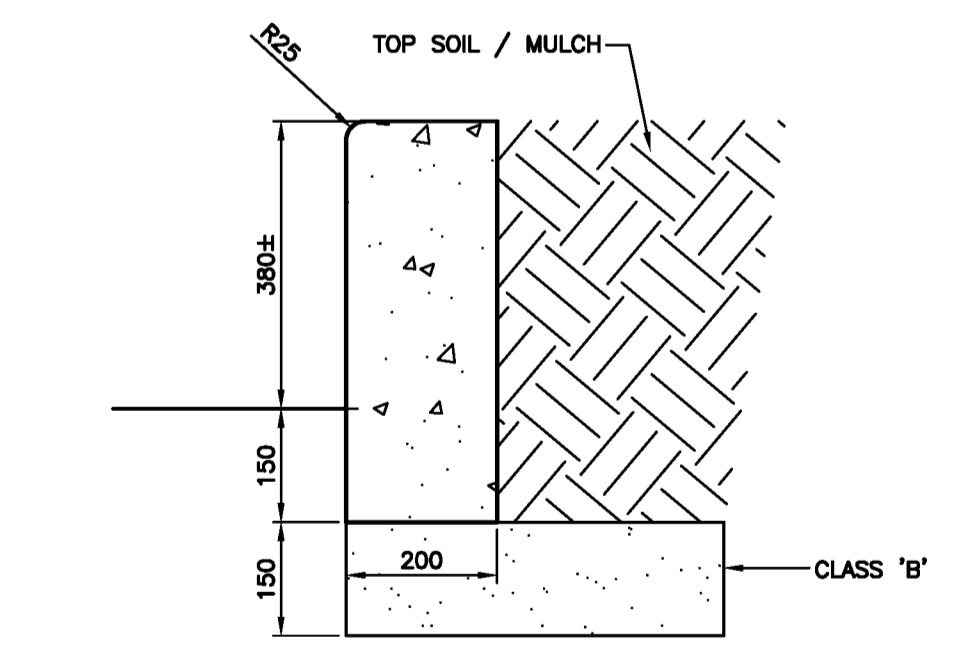

CONCRETE PLANTER CURB DETAIL
SCALE: 1:10

9
C-2.0

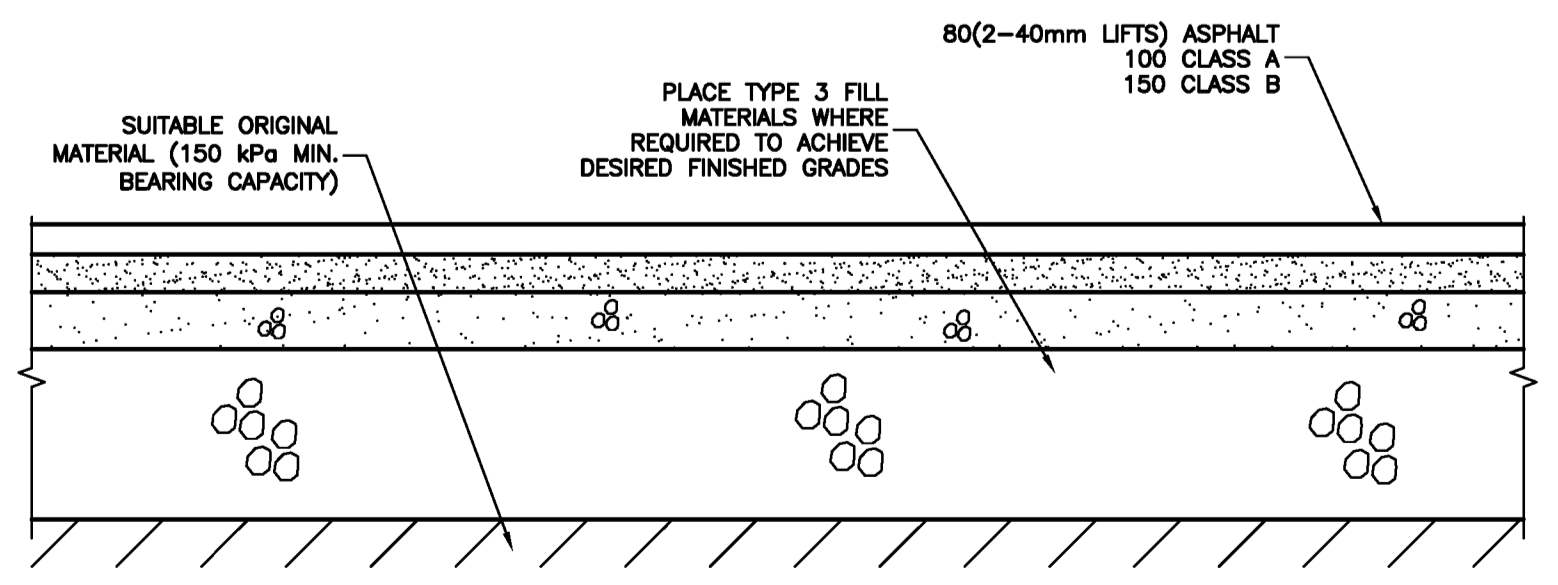

ASPHALT DETAIL
SCALE: 1:20

5
C-2.0

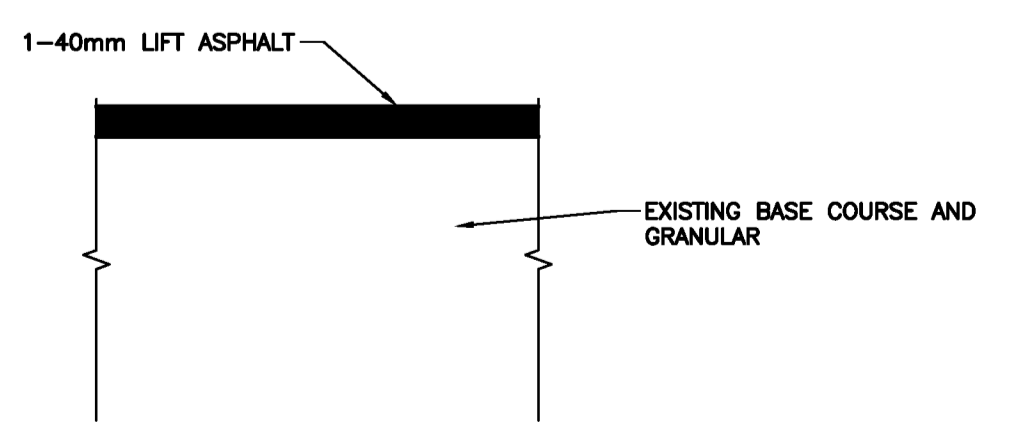

GRIND AND PATCH DETAIL
SCALE: 1:20

10
C-2.0

No.	REVISION	DATE
R1	ISSUED FOR TENDER	MAR 28, 2024
R0	ISSUED FOR REVIEW	MAR 14, 2024

GENERAL NOTES

1. DO NOT SCALE FROM DRAWINGS.
2. ALL DIMENSIONS IN MILLIMETRES UNLESS OTHERWISE NOTED.
3. THE CONTRACTOR IS TO VERIFY ALL DIMENSIONS AND SITE CONDITIONS PRIOR TO SUBMISSION OF TENDERS.
4. ALL DEFICIENCIES FOUND IN THIS DRAWING IS TO BE BROUGHT TO THE ATTENTION OF THE FACILITIES ENGINEERING AND DEVELOPMENT OFFICE OF THE DEPARTMENT OF FACILITIES MANAGEMENT, MEMORIAL UNIVERSITY OF NEWFOUNDLAND, PRIOR TO THE SUBMISSION OF THE TENDERS.

STAMP	
-------	--



Department of Facilities Management
This University was raised by the people of Newfoundland as a memorial to the fallen in the great wars, 1914-1918, 1939-1945, that in freedom of learning, their cause and sacrifice might not be forgotten.
Dedication plaque, Arts & Administration Building, St. John's Campus

PROJECT NAME:
CONCRETE AND ASPHALT REPAIRS 2024
Project #: GRD-508-23

DRAWING TITLE:
SECTIONS AND DETAILS

DESIGNED: S.C./C.B	DRAWN: S.C
REVIEWED: H.H	APPROVED: H.H
SCALE: AS SHOWN	DATE: MAR 28 2024
PROJECT No. GRD-508-23	DRAWING No. C-2.0

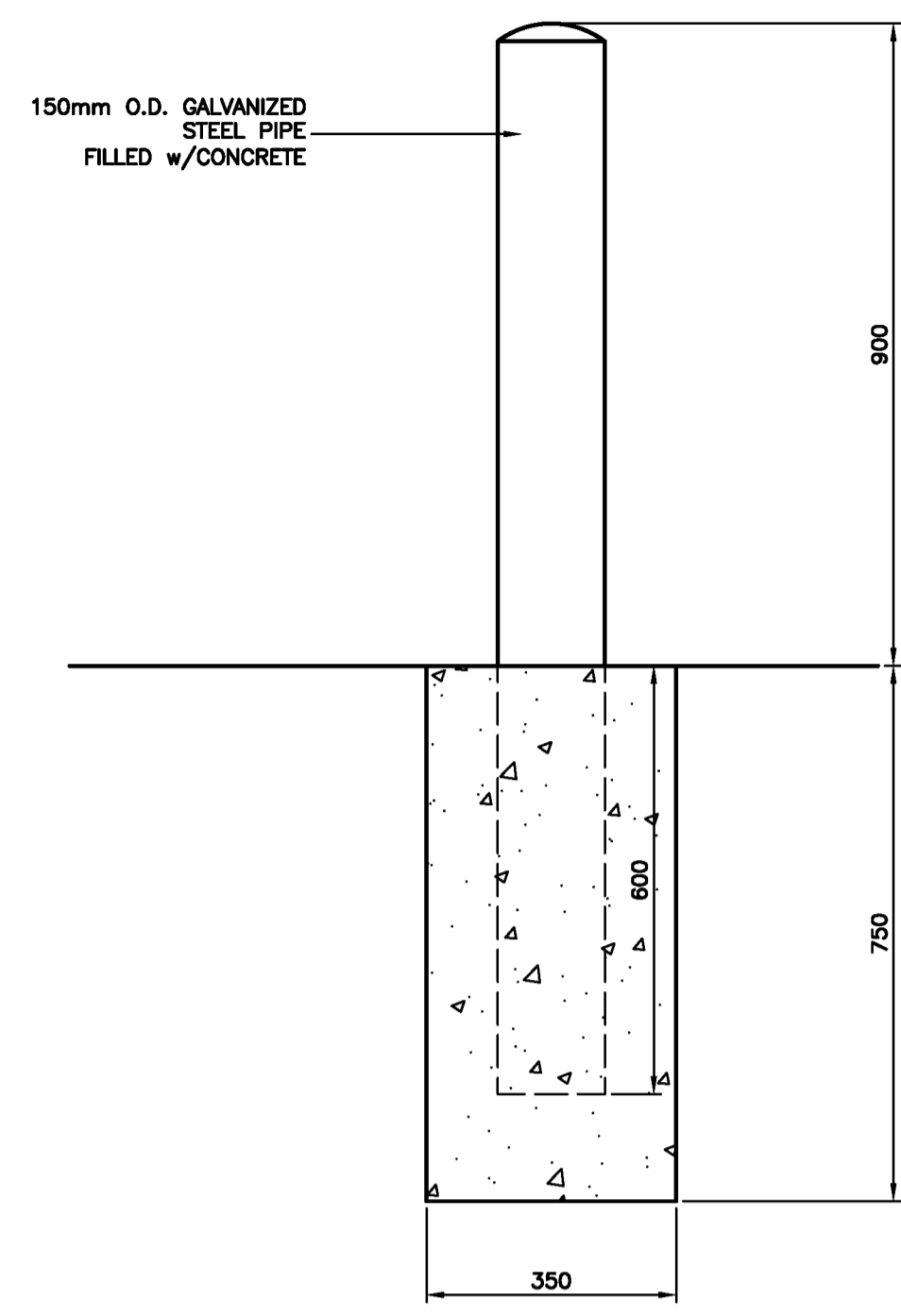

BOLLARD DETAIL
SCALE: 1:10

1
C-2.1

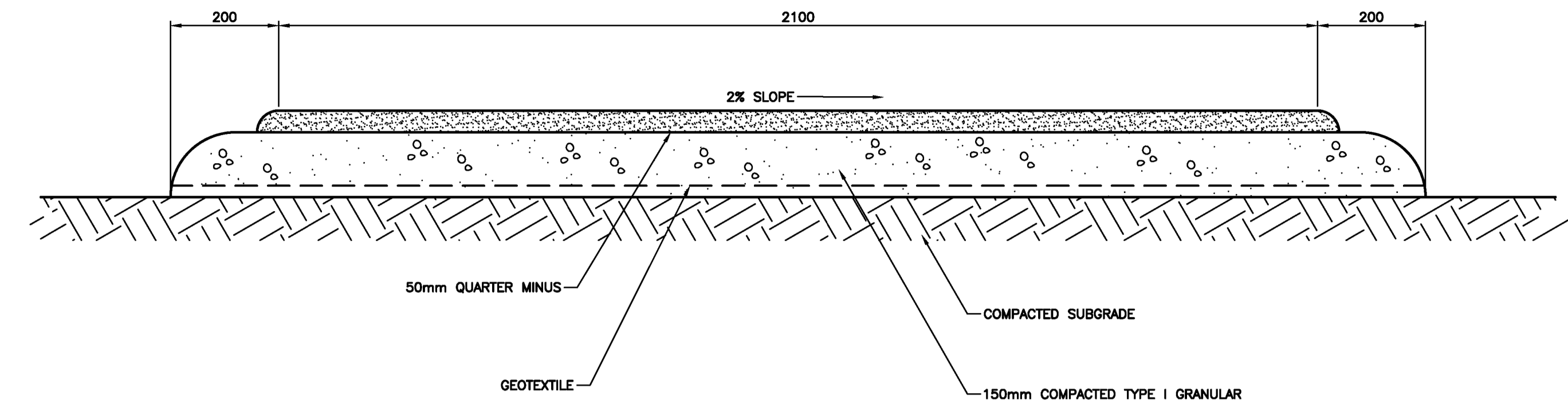

GRAVEL WALKWAY
SCALE: 1:10

2
C-2.1

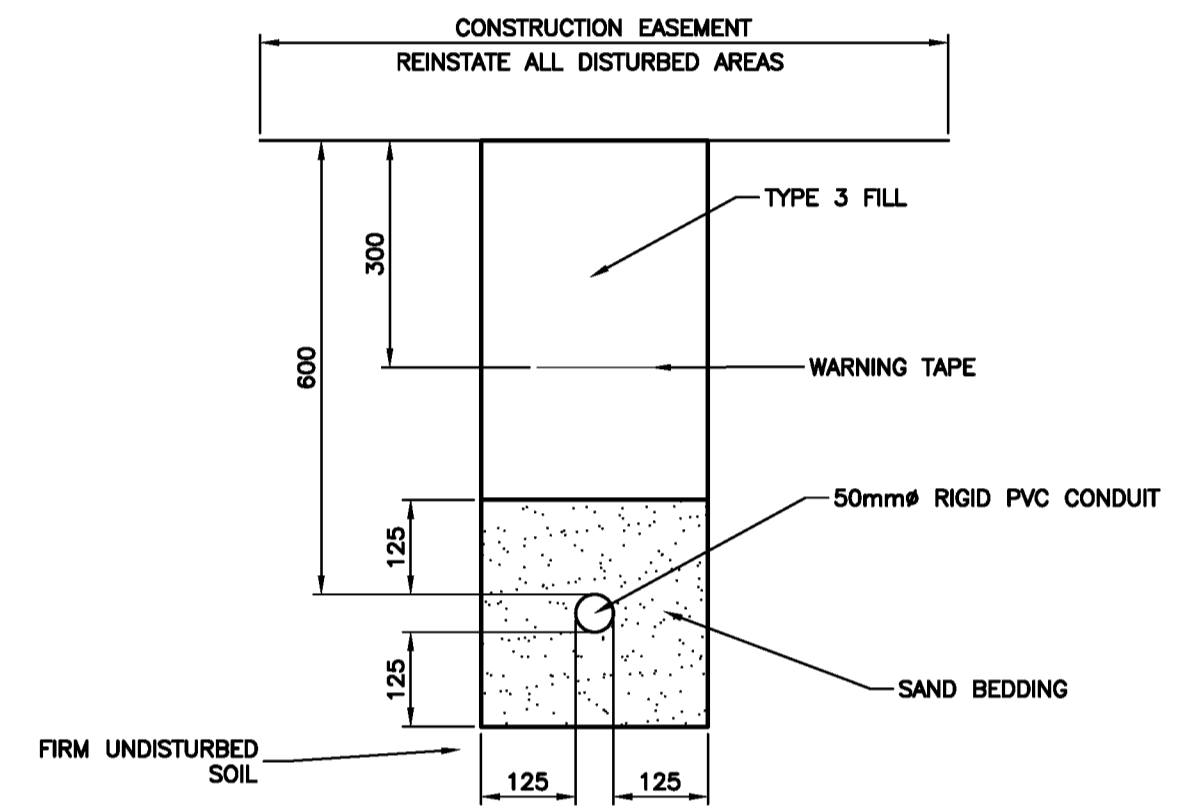

SINGLE CONDUIT TRENCH DETAIL
SCALE: 1:10

3
C-2.1

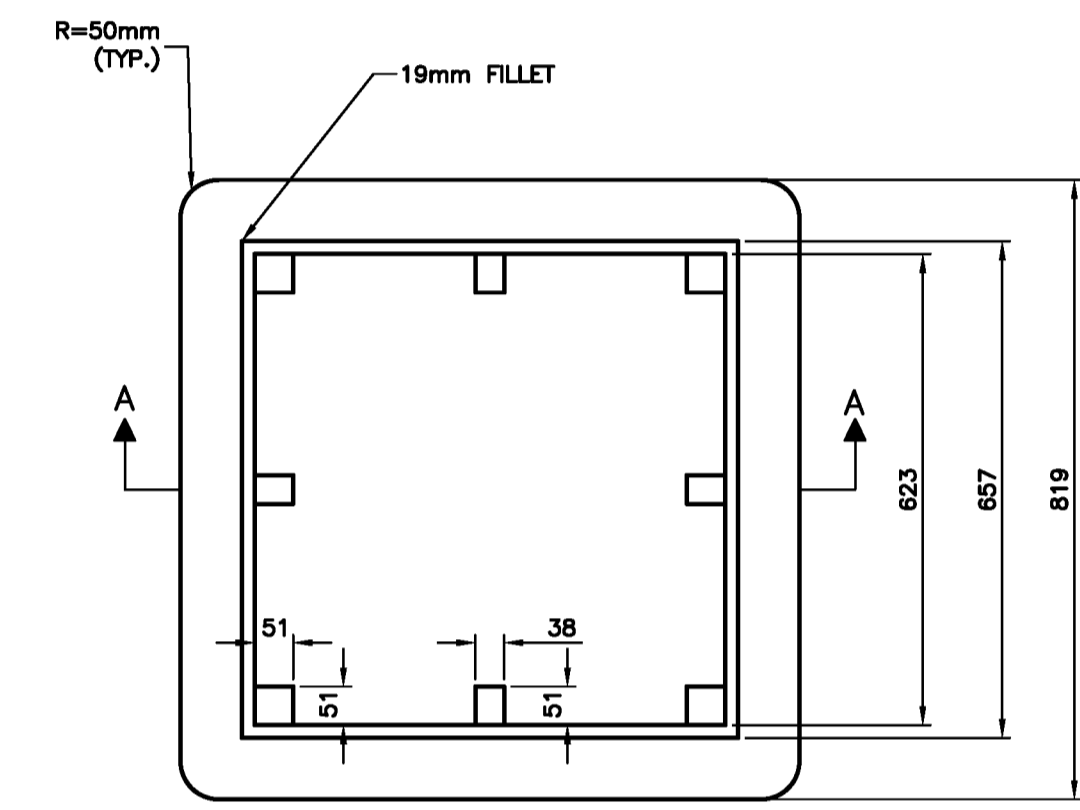

FRAME PLAN

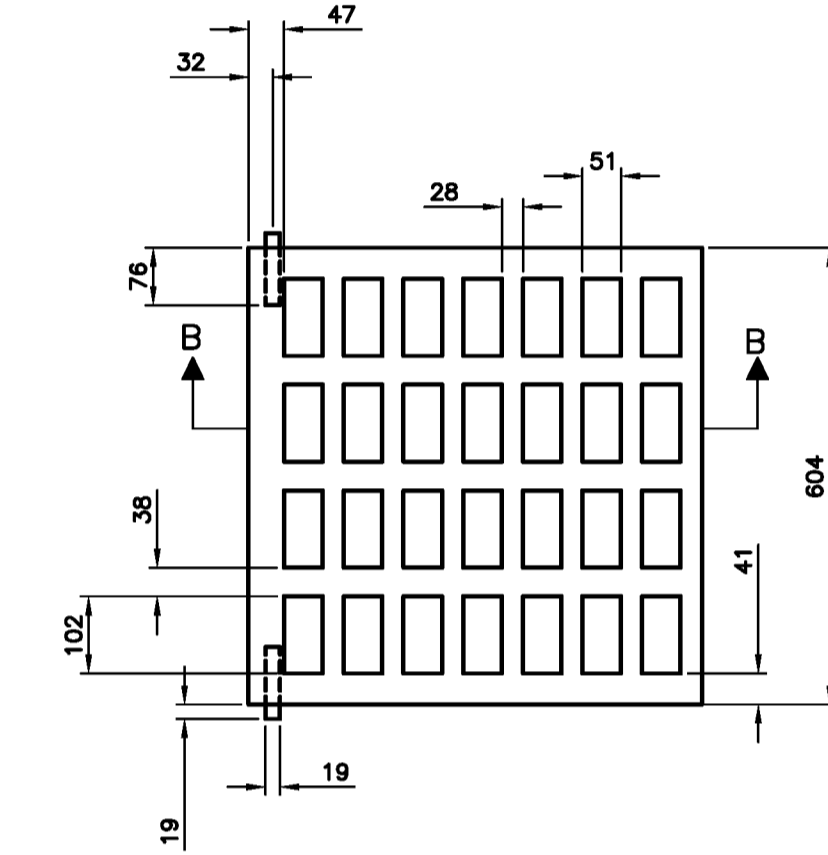

GRATE PLAN

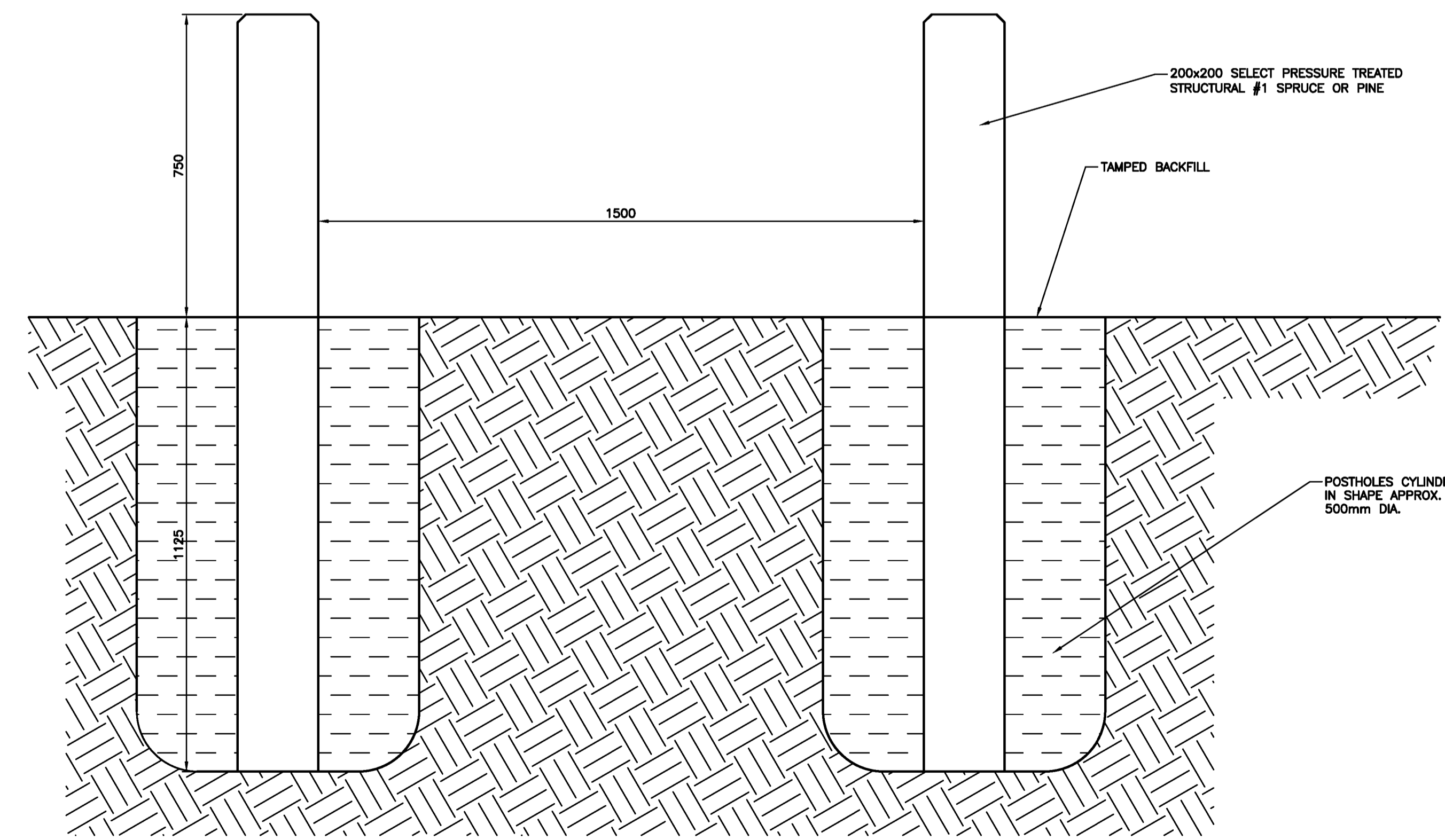

WOODEN POST DETAIL
SCALE: 1:10

5
C-2.1

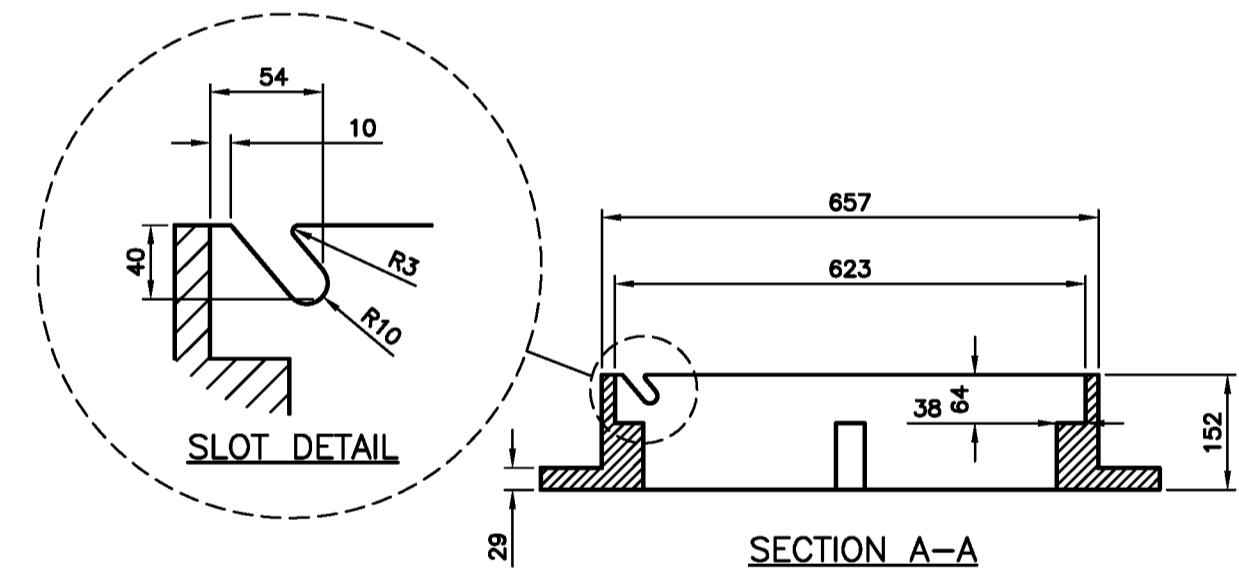

FRAME AND COVER DETAIL
SCALE: 1:10

4
C-2.1

No.	REVISION	DATE
R1	ISSUED FOR TENDER	MAR 28, 2024
R0	ISSUED FOR REVIEW	MAR 14, 2024

GENERAL NOTES

- DO NOT SCALE FROM DRAWINGS.
- ALL DIMENSIONS IN MILLIMETRES UNLESS OTHERWISE NOTED.
- THE CONTRACTOR IS TO VERIFY ALL DIMENSIONS AND SITE CONDITIONS PRIOR TO SUBMISSION OF TENDERS.
- ALL DEFICIENCIES FOUND IN THIS DRAWING IS TO BE BROUGHT TO THE ATTENTION OF THE FACILITIES ENGINEERING AND DEVELOPMENT OFFICE OF THE DEPARTMENT OF FACILITIES MANAGEMENT, MEMORIAL UNIVERSITY OF NEWFOUNDLAND, PRIOR TO THE SUBMISSION OF THE TENDERS.

STAMP



Department of Facilities Management
This University was raised by the people of Newfoundland as a memorial to the fallen in the great wars, 1914-1918, 1939-1945, that in freedom of learning, their cause and sacrifice might not be forgotten.
-Dedication plaque, Arts & Administration Building, St. John's Campus

PROJECT NAME:
CONCRETE AND ASPHALT REPAIRS 2024
Project #: GRD-508-23

DRAWING TITLE:
SECTIONS AND DETAILS

DESIGNED: S.C/C.B	DRAWN: S.C
REVIEWED: H.H	APPROVED: H.H
SCALE: AS SHOWN	DATE: MAR 28 2024
PROJECT No. GRD-508-23	DRAWING No. C-2.1